

A. GENERAL NOTES:

1. THE CONTRACTORS MUST VISIT THE SITE AND BECOME FAMILIARIZED WITH ALL CHARACTERISTICS AFFECTING NEW AND EXISTING CONSTRUCTION ON DRAWINGS AND REPORT ANY DISCREPANCIES TO THE ENGINEER BEFORE PROCEEDING WITH THE WORK, ANY CHANGES, ALTERATIONS, OR REVISIONS MUST BE REPORTED TO THE ENGINEER.
2. ALL MATERIAL AND WORK SHALL CONFORM TO THE ADOPTED CODE REQUIREMENTS OF THE APPLICABLE BUILDING DEPARTMENT.
3. NEITHER THE OWNER NOR CONTRACTOR WILL ENFORCE SAFETY MEASURES OR REGULATIONS. THE CONTRACTOR SHALL DESIGN, CONSTRUCT, AND MAINTAIN ALL SAFETY DEVICES INCLUDING SHORING AND BRACING, AND SHALL BE SOLELY RESPONSIBLE FOR CONFORMING TO ALL LOCAL, STATE AND FEDERAL SAFETY AND HEALTH STANDARDS, LAWS AND REGULATIONS. THE CONTRACT DRAWINGS AND SPECIFICATIONS REPRESENT THE FINISHED STRUCTURE AND DO NOT INDICATE METHODS, PROCEDURES OR SEQUENCE OF CONSTRUCTION. THE CONTRACTOR SHALL TAKE NECESSARY PRECAUTIONS TO MAINTAIN AND INSURE THE INTEGRITY OF THE STRUCTURE DURING CONSTRUCTION. IF A LAWSUIT IS FILED BY ONE OF THE CONTRACTOR'S OR SUBCONTRACTOR'S EMPLOYEES, OR ANY ONE ELSE, THE CONTRACTOR WILL INDEMNIFY, DEFEND AND HOLD THE OWNER AND POLAR RACKING HARMLESS OF ANY AND ALL SUCH CLAIMS.
4. NO PIPES, DUCTS, SLEEVES, CHASE ETC., SHALL BE PLACED CONCRETE PIERS, UNLESS SPECIFICALLY SHOWN OR NOTED. NOR SHALL ANY STRUCTURAL MEMBER BE CUT FOR PIPES, DUCTS, ETC., UNLESS SPECIFICALLY SHOWN. OBTAIN PRIOR WRITTEN APPROVAL FOR INSTALLATION OF ANY ADDITIONAL PIPES, DUCTS, ETC.
5. CONTRACTOR TO CONFIRM WITH PV MODULE INSTALLATION MANUAL FOR CLAMPING ZONES TO ENSURE THEY ARE FASTENED PER MODULE REQUIREMENTS.

B: LOADING PARAMETERS:

DEAD LOAD

TOTAL WEIGHT :0.13 kPa
 STEEL MEMBERS :ACTUAL WEIGHT OF MEMBERS

SNOW AND WIND LOAD COMBINATION FALLING BELOW THE LINE SHOWN IN THE GRAPH BELOW IS ACCEPTABLE

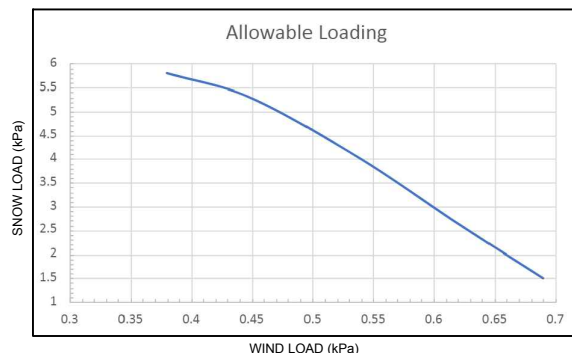

PILE DESIGN: REFER TO PILE DESIGN DOCUMENTS AND DRAWINGS FOR FOUNDATION REACTION LOADS

C: STRUCTURAL STEEL NOTES:

1. RACKING SYSTEM WAS DESIGNED TO SPECIFIED CLIMATIC LOADS AT GROUND LEVEL
2. WIND LOADS HAVE BEEN PRODUCED BASED ON POLAR RACKING PROPRIETARY WIND TUNNEL TESTS RESULTS BY CPP INC.
3. POSITIVE LOADS ARE DOWNWARD I.E COMPRESSIVE LOADS, NEGATIVE LOADS ARE UPLIFT I.E. TENSION LOADS
4. LOADS ARE SPECIFIED VALUES AND MUST BE COMBINED AS PER NBC PART 4
5. REACTION LOADS ASSUME NOMINAL INSTALLATION LOCATIONS
6. LATEST AISI & CSA STANDARD SHALL BE CONSIDERED TO FABRICATE OR DESIGN ANY STEEL COMPONENTS ON RACK
7. INSTALLATION MANUAL SHALL BE USED FOR TORQUE VALUE ON ALL STRUCTURAL CONNECTION POINTS
8. ALL WELDING OF STEEL SHALL BE DONE IN ACCORDANCE WITH THE LATEST VERSION OF CSA W59-03" WELDED STEEL CONSTRUCTION (METAL ARC WELDING)" BY WELDERS CERTIFIED AS PER CSA W47.1
9. SELF-DRILLING SCREWS SHOULD BE INSTALLED WITH NON-IMPACTING VARIABLE SPEED DRILL WITH CLUTCH OUT
10. PV MODULE HARDWARE SHOULD BE TORQUED AND INSPECTED AS PER MODULE MANUFACTURER'S RECOMMENDATIONS
11. DESIGN, FABRICATION AND ERECTION SHALL CONFORM TO THE SPECIFICATIONS AND STANDARDS OF THE CISC CODE OF STANDARD PRACTICE FOR STRUCTURAL STEEL 8TH EDITION (2015).
12. STRUCTURAL STEEL GRADES:
13. SHAPES AND PLATES ASTM A572 OR ASTM A992, GRADE 50 (Fy=50 KSI)
14. WIDE FLANGE BEAMS & COLUMNS ASTM A572 OR ASTM A992, GRADE 50 (Fy=50 KSI)
15. HIGH STRENGTH BOLTS, NUTS, AND WASHER: SAE J429 GR.5; NUT: SAE J429 GR.5, (F436)
16. PRE -GALVANIZED MATERIAL SHALL COMPLY WITH ASTM A653 - G90 MIN.
17. ALL CONNECTIONS NOT SHOWN SHALL CONFORM TO THE "CISC", 8TH EDITION.
18. ALL INSTALLATION WORK SHALL BE DONE IN ACCORDANCE WITH THE FEDERAL AND PROVINCIAL CODES AND STANDARD SPECIFICATIONS.

D: LIGHT GAUGE METAL NOTES:

1. DESIGN, FABRICATION AND ERECTION SHALL CONFORM TO THE SPECIFICATIONS AND STANDARDS OF THE CSA-136-16 "NORTH AMERICAN SPECIFICATION FOR THE DESIGN OF COLD-FORMED STEEL STRUCTURAL MEMBERS.
2. NORTH-SOUTH BEAMS, EAST-WEST BEAMS AND BRACES SHALL BE FORMED TO CHANNEL SHAPE, PUNCHED WEB AND KNURLED FACES, CONFORMING TO ASTM DESIGNATION: A - 446, GRADE 50.
3. NORTH-SOUTH BEAMS, EAST-WEST BEAMS AND BRACES MINIMUM GAUGE THICKNESS ARE SIZED AS SHOWN ON THE RACKING DRAWINGS.



6889 Rowwood Unit 5, Mississauga, ON L4V 1R2
 TEL: 416-860-6722 FAX: 416-860-6719
 www.polarracking.com



PERMIT TO PRACTICE
 VAN EE ENGINEERING INC.
 P.M. SIGNATURE: [Signature]
 P.M. APEGA ID #: 212064
 DATE: 2021/08/24
 PERMIT NUMBER: P015001
 The Associate of Professional Engineers and Geoscientists of Alberta (APEGA)

00	ISSUED FOR CONSTRUCTION	24AUG21
REV NO.	ISSUANCE	DATE
PROJECT NAME: 2X8 PRU-D GROUND MOUNT		
DRAWING NAME: GENERAL NOTES		
PROJ. NO.:	DWG. BY:	CHKD. BY:
-	VT	MA
		APPR. BY:
		DV
DRAWING NUMBER:		L-01

THIS DRAWING IS THE PROPERTY OF POLAR RACKING INCLUDING THE PRINCIPLES OF THE DESIGN INVOLVED. IT IS SUBMITTED WITH THE AGREEMENT THAT IT IS NOT TO BE REPRODUCED, SHARED OR DISTRIBUTED IN PART OR IN WHOLE. ACCEPTANCE OF THE DRAWING IS CONSTRUED AS AGREEMENT TO THE ABOVE.

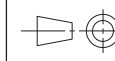

SHEET 1 OF 4

REV.: A

RACK TILT ANGLE (degrees) : 30°

GENERAL NOTES:

- CONTRACTOR TO CONFIRM WITH PV MODULE INSTALLATION MANUAL FOR CLAMPING ZONES TO ENSURE THEY ARE FASTENED PER MODULE REQUIREMENTS.
- ORIGINAL WARRANTY WILL BE MAINTAINED IF ADJUSTMENTS MEET DRAWING SPECIFICATIONS

CLIMATIC DESIGN LOADS

SNOW AND WIND LOAD COMBINATION FALLING BELOW THE LINE IS ACCEPTABLE

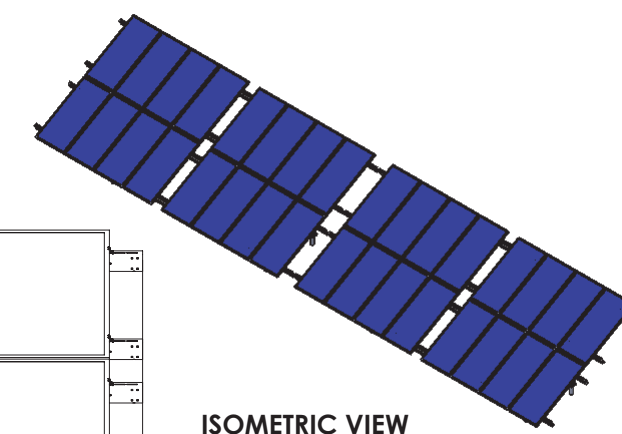
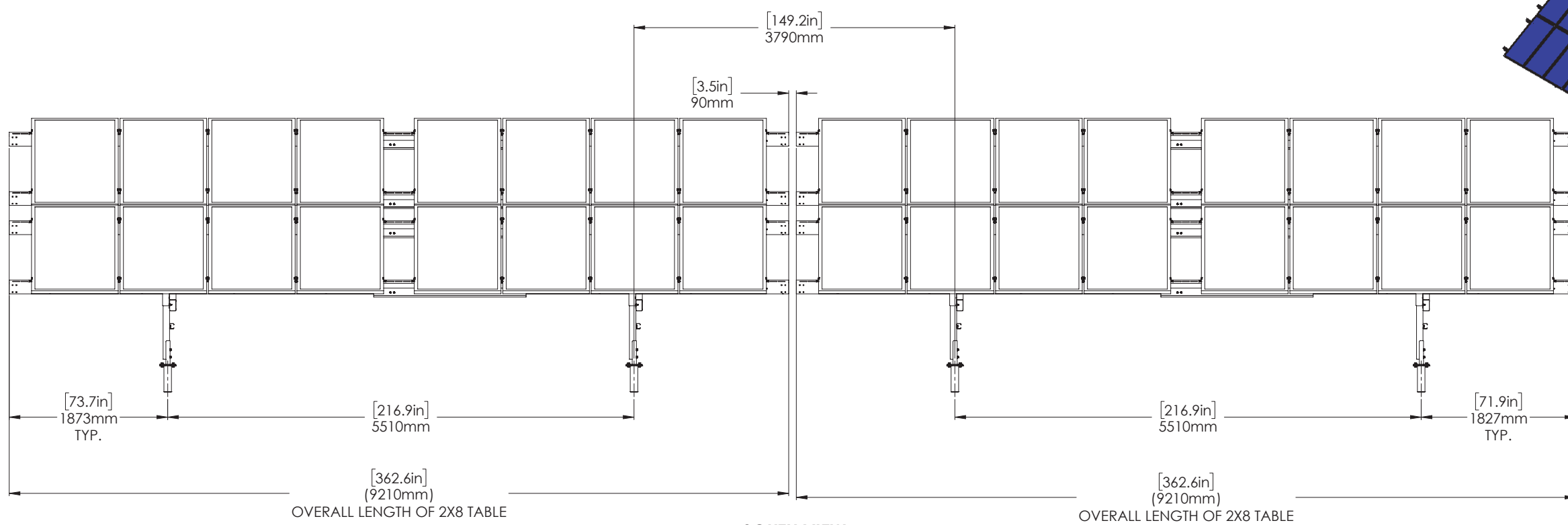
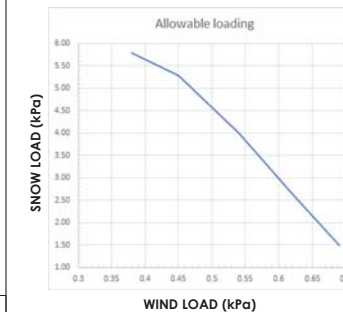

POST HSS ROUND CROSS SECTION

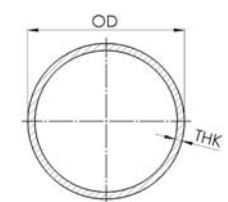

TYPICAL PROFILES

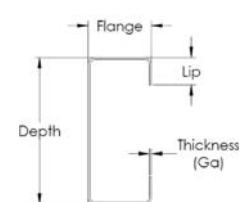

PART	PROFILE (in.) Depth x Flange x Lip	MIN. THICKNESS (MM)	MATERIAL Fy (ksi)
POST	3.5" OD	6.35	50
TABLE LEG (FRONT)	6 X 3 X 1	2.35	50
		2.15	55
TABLE LEG (BACK)	6 X 3 X 1	2.65	50
		2.50	60
EAST-WEST BEAM	6 X 3 X 1	2.50	50
NORTH-SOUTH BEAM	6 X 3 X 1	2.50	50
BRACE	2.5 X 2.0 X 0.5	2.35	50
		2.15	55

MAIN COMPONENTS BILL OF MATERIAL FOR 2X8

ITEM NO.	PART NUMBER	DESCRIPTION	QTY.
2	900286002	Foot Bracket, Assembly, PRU Dual Leg, 6" C-Channel Post, 6x150 mm bolt circle Ground Screw, Adjustable N-S	4
3	300474002	Beam, EWE, C6x3x1, Ga12, 3998 mm, G90, P-2x8, Distr.	4
4	300475002	Beam, EWW, C6x3x1, Ga12, 5202 mm, G90, P-2x8, Distr.	4
5	300471002	Beam, NS, C6x3x1, Ga12, 3811 mm, G90, P-1P/2P, Distr.	2
6	300346004	Table Leg, Front, C6x3x1, Ga13, 1285 mm, G90, 30° Tilt	2
7	300345002	Beam, EW Splice, C6x3x1, Ga12, 1800 mm, G90, P-2x8, Distr.	4
8	300341002	Table Leg, Back, C6x3x1, Ga12, 2235 mm, G90, 30° Tilt	2
9	300324004	Brace, Lateral, C2.5x2x0.5, Ga13, 1850 mm, G90	4
10	300313XXX*	POST, 3.5" O.D., 0.25" WALL, ASTM A252, 50KSI Y.S	4
11	300232001	Bracket, East-West, Ga 10 , 6 in Beams	8

* Total embedment depth of the post varies, depending on overburden thickness.

HARDWARE BILL OF MATERIAL FOR 2X8

ITEM NO.	PART NUMBER	DESCRIPTION	QTY.
14	100045010	Bolt, Carriage, 5/16"-18 x 2-1/2", Gr. 5, Magni 565	104
15	100063004	Nut, Hex Flange, Serrated, 5/16"-18, Gr. 5, Magni 565	168
16	100064005	Bolt, Hex Flange, Serrated, 5/16"-18 x 1", Gr. 5, Magni 565	64
17	100014015	Cap Screw, Hex Head, 1/2"-13 x 1-1/2", Gr. 8, HDG	8
18	100011009	Washer, Flat, 3/8" x 1" O.D., HDG	56
19	100033017	Washer, Split Lock, 3/8", HDG	48
20	100015002	Nut, Hex Head, 1/2"-13, A194 Grade-2H, HDG	8
22	400029001	Bonding Washer, WEEB-DSK516-45	20

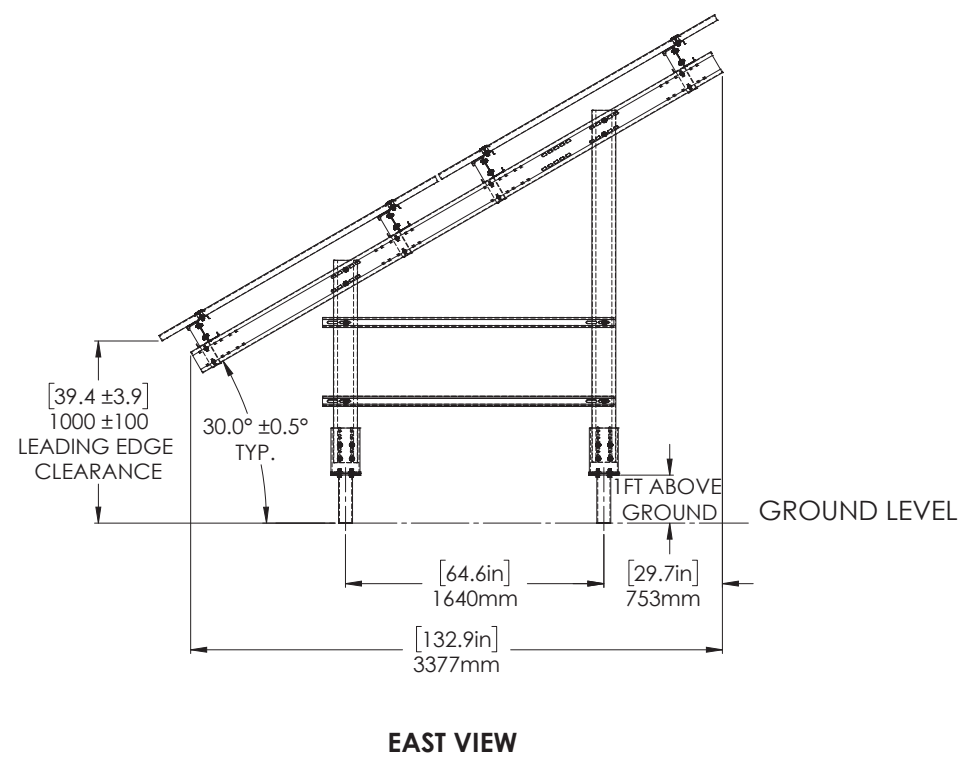

PERMIT TO PRACTICE
VAN EE ENGINEERING INC.
 RM SIGNATURE: [Signature]
 RM APEGA ID #: 212064
 DATE: 2021/08/24
PERMIT NUMBER: P015001
 The Associate of Professional Engineers and Geoscientists of Alberta (APEGA)

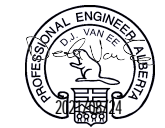

VAN EE ENGINEERING INC.
 STRUCTURAL CONSULTANT
 416-859-2222
 VANEEENGINEERING.CA

PROJECT NAME:
 2X8 CONNECTION WITH 2X8 PRU-D DUAL C-CHANNEL LEG GROUND MOUNT

TITLE:
 PRU-D TABLE FRAME ASSEMBLY, PORTRAIT, DUAL C-CHANNEL LEG, 30°, MOD. (1950-2300)X(990-1112)X(26-50) mm

PROJ. NO.: PRU-D
 DWG. BY: PY
 CHECKED BY: MA
 SCALE: NTS

POLAR INTERNAL ASSEMBLY NUMBER:
 900510004

DRAWING NUMBER:
 S-03-1

THIS DRAWING IS THE PROPERTY OF POLAR RACKING INCLUDING THE PRINCIPLES OF THE DESIGN INVOLVED. IT IS SUBMITTED WITH THE AGREEMENT THAT IT IS NOT TO BE REPRODUCED, SHARED OR DISTRIBUTED IN PART OR IN WHOLE. ACCEPTANCE OF THE DRAWING IS CONSTRUED AS AGREEMENT TO THE ABOVE.

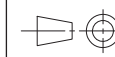

SHEET 2 OF 4

REV.: A

A

RACK TILT ANGLE (degrees) : 30°

GENERAL NOTES:

- CONTRACTOR TO CONFIRM WITH PV MODULE INSTALLATION MANUAL FOR CLAMPING ZONES TO ENSURE THEY ARE FASTENED PER MODULE REQUIREMENTS.
- ORIGINAL WARRANTY WILL BE MAINTAINED IF ADJUSTMENTS MEET DRAWING SPECIFICATIONS

CLIMATIC DESIGN LOADS

SNOW AND WIND LOAD COMBINATION FALLING BELOW THE LINE IS ACCEPTABLE

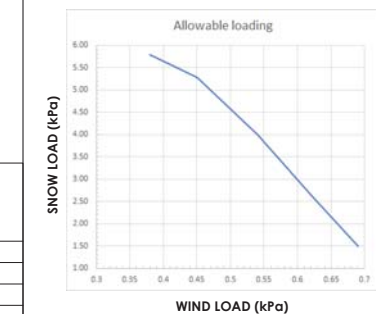

PERMIT TO PRACTICE
VAN EE ENGINEERING INC.
 RM SIGNATURE: [Signature]
 RM APEGA ID #: 212064
 DATE: 2021/08/24
PERMIT NUMBER: P015001
 The Associate of Professional Engineers and Geoscientists of Alberta (APEGA)

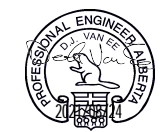

VAN EE ENGINEERING INC.
 STRUCTURAL CONSULTANT
 416-859-2222
 VANEEENGINEERING.CA

PROJECT NAME:

2X8 CONNECTION WITH 2X7 PRU-D DUAL C-CHANNEL LEG GROUND MOUNT

TITLE:

PRU-D TABLE FRAME ASSEMBLY,, PORTRAIT, DUAL C-CHANNEL LEG, 30°, MOD. (1950-2300)X(990-1112)X(26-50) mm MODIFIED FOR 2X7

PROJ. NO.:	DWG. BY:	CHECKED. BY:	SCALE:
PRU-D	PY	MA	NTS

POLAR INTERNAL ASSEMBLY NUMBER: 900510001

DRAWING NUMBER:

S-03-1

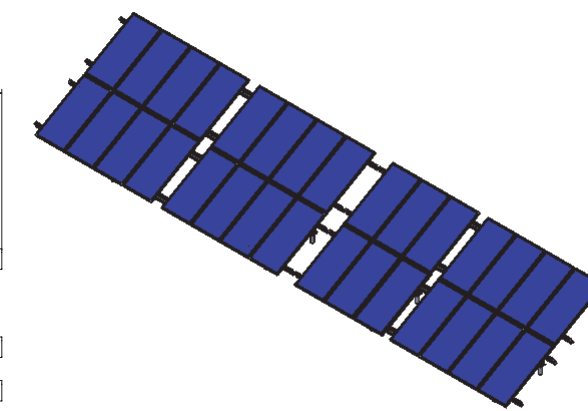
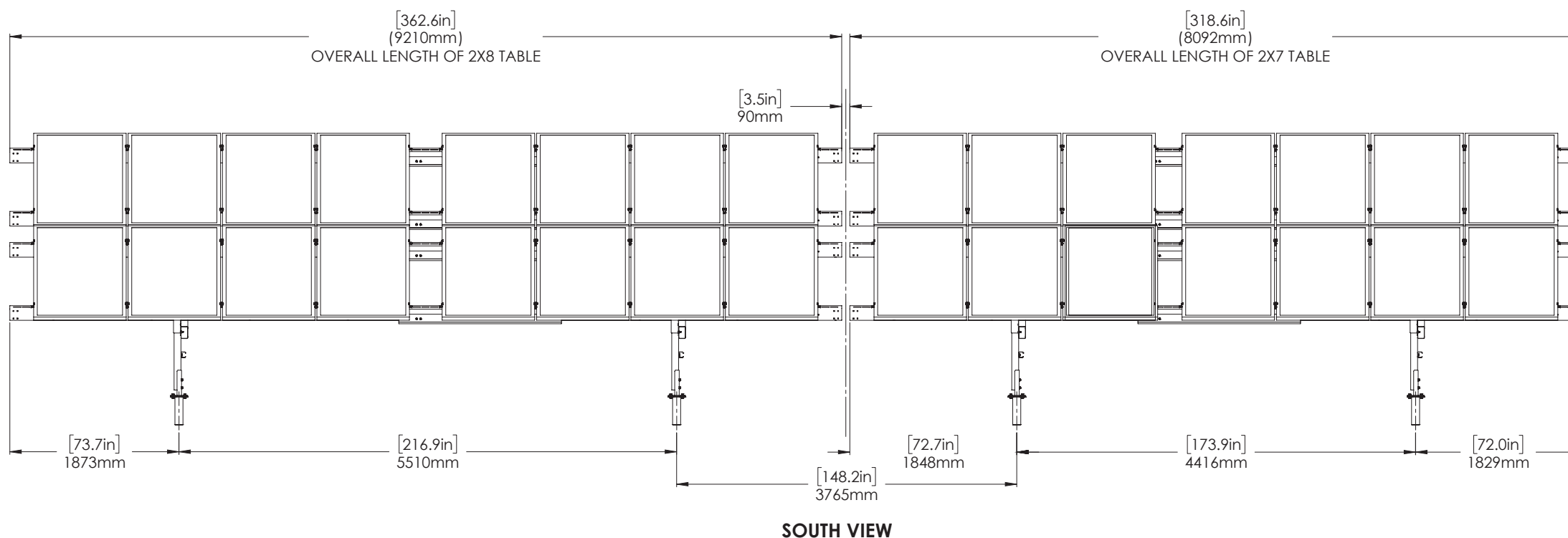

ISOMETRIC VIEW

POST HSS ROUND CROSS SECTION

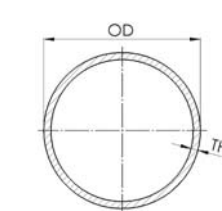

TYPICAL PROFILES

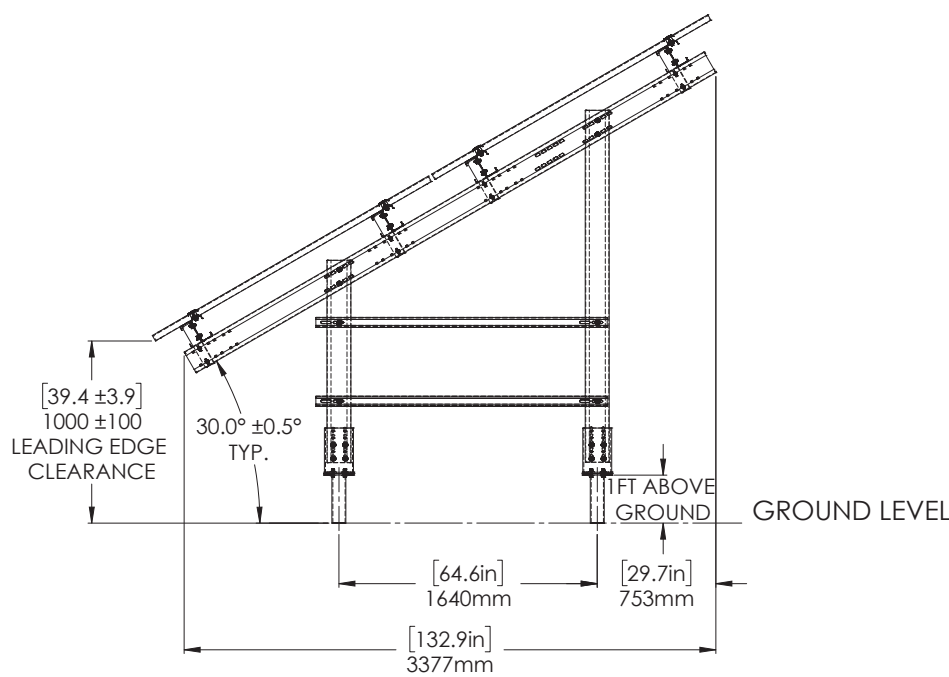
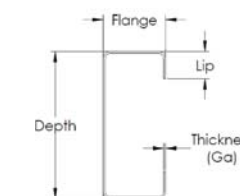

EAST VIEW

MAIN COMPONENTS BILL OF MATERIAL FOR 2X8

ITEM NO.	PART NUMBER	DESCRIPTION	QTY.
2	900286002	Foot Bracket, Assembly, PRU Dual Leg, 6" C-Channel Post, 6x150 mm bolt circle Ground Screw, Adjustable N-S	4
3	300474002	Beam, EWE, C6x3x1, Ga12, 3998 mm, G90, P-2x8, Distr.	4
4	300475002	Beam, EWW, C6x3x1, Ga12, 5202 mm, G90, P-2x8, Distr.	4
5	300471002	Beam, NS, C6x3x1, Ga12, 3811 mm, G90, P-1P/2P, Distr.	2
6	300346004	Table Leg, Front, C6x3x1, Ga13, 1285 mm, G90, 30° Tilt	2
7	300345002	Beam, EW Splice, C6x3x1, Ga12, 1800 mm, G90, P-2x8, Distr.	4
8	300341002	Table Leg, Back, C6x3x1, Ga12, 2235 mm, G90, 30° Tilt	2
9	300324004	Brace, Lateral, C2.5x2x0.5, Ga13, 1850 mm, G90	4
10	300313XXX*	POST, 3.5" O.D., 0.25" WALL, ASTM A252, 50KSI Y.S	4
11	300232001	Bracket, East-West, Ga 10 , 6 in Beams	8

HARDWARE BILL OF MATERIAL FOR 2X8

ITEM NO.	PART NUMBER	DESCRIPTION	QTY.
14	100045010	Bolt, Carriage, 5/16"-18 x 2-1/2", Gr. 5, Magni 565	104
15	100063004	Nut, Hex Flange, Serrated, 5/16"-18, Gr. 5, Magni 565	168
16	100064005	Bolt, Hex Flange, Serrated, 5/16"-18 x 1", Gr. 5, Magni 565	64
17	100014015	Cap Screw, Hex Head, 1/2"-13 x 1-1/2", Gr. 8, HDG	8
18	100011009	Washer, Flat, 3/8" x 1" O.D., HDG	56
19	100033017	Washer, Split Lock, 3/8", HDG	48
20	100015002	Nut, Hex Head, 1/2"-13, A194 Grade-2H, HDG	8
22	400029001	Bonding Washer, WEEB-DSK516-45	20

MAIN COMPONENTS BILL OF MATERIAL FOR 2X7

ITEM NO.	PART NUMBER	DESCRIPTION	QTY.
2	900286001	Foot Bracket, Assembly, PRU Dual Leg, 6" C-Channel Post, 6x150 mm bolt circle Ground Screw, Adjustable N-S	4
3	300475002-MOD For 2X7	Beam, EWE, C6x3x1, Ga14, 2x18, 4084mm, 1994x1000x35mm PV	4
4	300474002	Beam, EWE, C6x3x1, Ga12, 3998 mm, G90, P-2x8, Distr.	4
5	300471002	Beam, NS, C6x3x1, Ga12, 3811 mm, G90, P-1P/2P, Distr.	2
6	300346004	Table Leg, Front, C6x3x1, Ga13, 1285 mm, G90, 30° Tilt	2
7	300345002	Beam, EW Splice, C6x3x1, Ga12, 1800 mm, G90, P-2x8, Distr.	4
8	300341002	Table Leg, Back, C6x3x1, Ga12, 2235 mm, G90, 30° Tilt	2
9	300324004	Brace, Lateral, C2.5x2x0.5, Ga13, 1850 mm, G90	4
10	300313XXX*	POST, 3.5" O.D., 0.25" WALL, ASTM A252, 50KSI Y.S	4
11	300232001	Bracket, East-West, Ga 10 , 6 in Beams	8

* Total embedment depth of the post varies, depending on overburden thickness.

HARDWARE BILL OF MATERIAL FOR 2X7

ITEM NO.	PART NUMBER	DESCRIPTION	QTY.
12	100064003	Bolt, Hex Flange, Serrated, 1/2"-13 x 1", Gr. 5, Magni 565	48
13	100063002	Nut, Hex Flange, Serrated, 1/2"-13, Gr. 5, Magni 565	48
14	100063001	Nut, Hex Flange, Serrated, 3/8"-16, Gr. 5, Magni 565	80
15	100045009	Bolt, Carriage, 3/8"-16 x 1", Gr. 5, Magni 565	80
16	100033002	Washer, Split Lock, 1/2", HDG	8
17	100015002	Nut, Hex Head, 1/2"-13, A194 Grade-2H, HDG	8
18	100014015	Cap Screw, Hex Head, 1/2"-13 x 1-1/2", Gr. 8, HDG	8
19	100011004	Washer, Flat, 1/2" x 1.375" O.D., HDG	16

THIS DRAWING IS THE PROPERTY OF POLAR RACKING INCLUDING THE PRINCIPLES OF THE DESIGN INVOLVED. IT IS SUBMITTED WITH THE AGREEMENT THAT IT IS NOT TO BE REPRODUCED, SHARED OR DISTRIBUTED IN PART OR IN WHOLE. ACCEPTANCE OF THE DRAWING IS CONSTRUED AS AGREEMENT TO THE ABOVE.

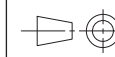

SHEET 3 OF 4

REV.: A

RACK TILT ANGLE (degrees) : 30°

GENERAL NOTES:

- CONTRACTOR TO CONFIRM WITH PV MODULE INSTALLATION MANUAL FOR CLAMPING ZONES TO ENSURE THEY ARE FASTENED PER MODULE REQUIREMENTS.
- ORIGINAL WARRANTY WILL BE MAINTAINED IF ADJUSTMENTS MEET DRAWING SPECIFICATIONS

CLIMATIC DESIGN LOADS
 SNOW AND WIND LOAD COMBINATION FALLING BELOW THE LINE IS ACCEPTABLE

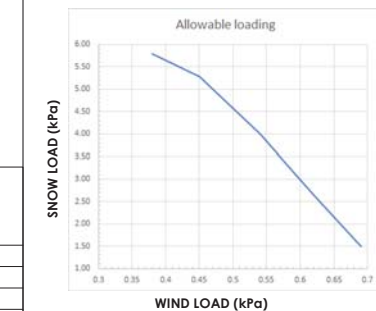

PERMIT TO PRACTICE
VAN EE ENGINEERING INC.
 RM SIGNATURE: [Signature]
 RM APEGA ID #: 212064
 DATE: 2021/08/24
PERMIT NUMBER: P015001
 The Associate of Professional Engineers and Geoscientists of Alberta (APEGA)

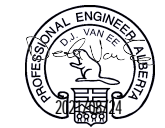

VAN EE ENGINEERING INC.
 STRUCTURAL CONSULTANT
 416-859-2222
 VANEEENGINEERING.CA

PROJECT NAME:

2X8 CONNECTION WITH 2X6 PRU-D DUAL C-CHANNEL LEG GROUND MOUNT

TITLE:
 PRU-D TABLE FRAME ASSEMBLY,, PORTRAIT, DUAL C-CHANNEL LEG, 30°, MOD. (1950-2300)X(990-1112)X(26-50) mm MODIFIED FOR 2X6

PROJ. NO.:	DWG. BY:	CHECKED. BY:	SCALE:
PRU-D	PY	MA	NTS

POLAR INTERNAL ASSEMBLY NUMBER:
 900510002

DRAWING NUMBER:
 S-03-1

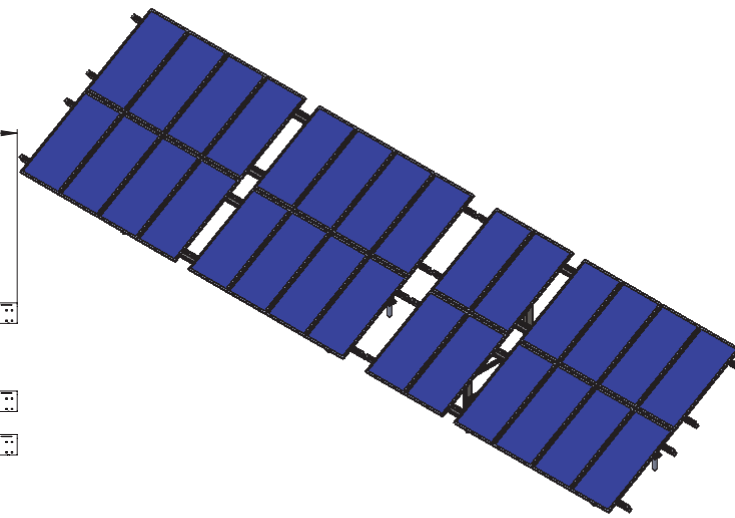
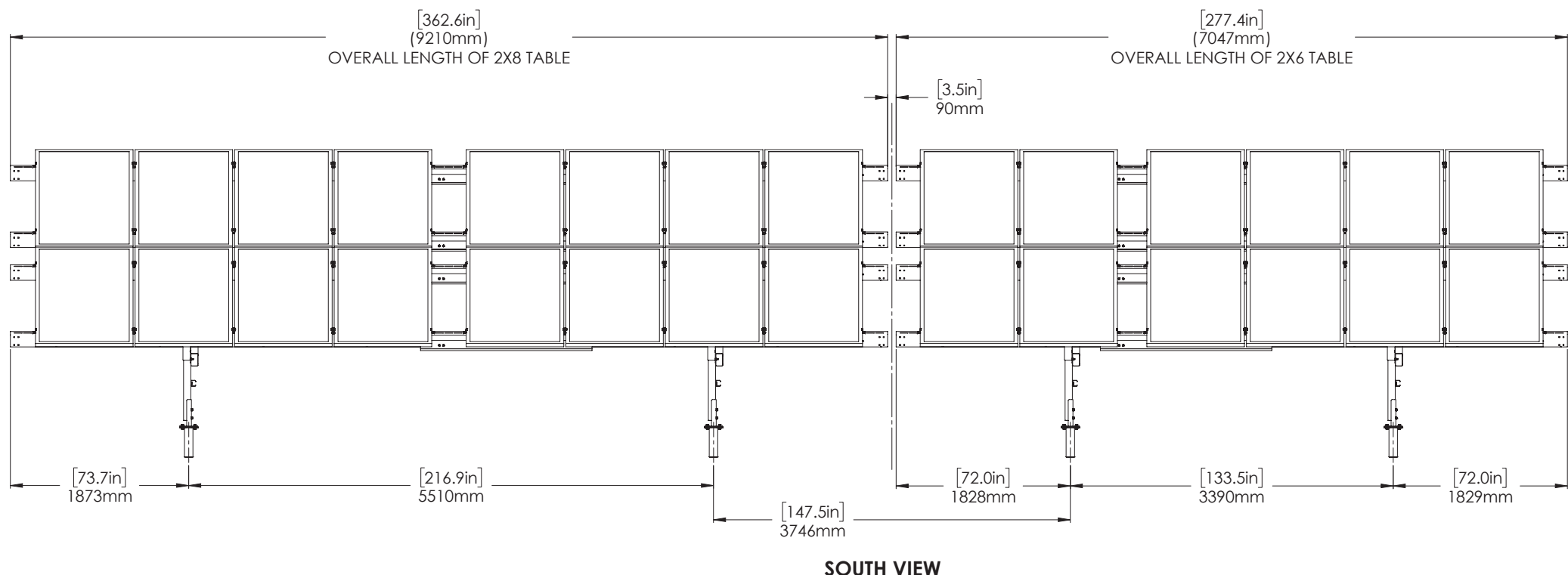

ISOMETRIC VIEW

POST HSS ROUND CROSS SECTION

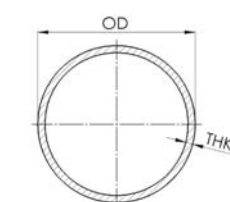

TYPICAL PROFILES

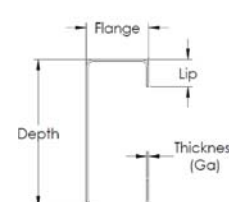

PART	PROFILE (in.) Depth x Flange x Lip	MIN. THICKNESS (MM)	MATERIAL Fy (ksi)
POST	3.5" OD	6.35	50
TABLE LEG (FRONT)	6 X 3 X 1	2.35	50
TABLE LEG (BACK)	6 X 3 X 1	2.15	55
EAST-WEST BEAM	6 X 3 X 1	2.65	50
NORTH-SOUTH BEAM	6 X 3 X 1	2.50	60
BRACE	2.5 X 2.0 X 0.5	2.50	50
		2.35	50
		2.15	55

MAIN COMPONENTS BILL OF MATERIAL FOR 2X8

ITEM NO.	PART NUMBER	DESCRIPTION	QTY.
2	900286002	Foot Bracket, Assembly, PRU Dual Leg, 6" C-Channel Post, 6x150 mm bolt circle Ground Screw, Adjustable N-S	4
3	300474002	Beam, EWE, C6x3x1, Ga12, 3998 mm, G90, P-2x8, Distr.	4
4	300475002	Beam, EWW, C6x3x1, Ga12, 5202 mm, G90, P-2x8, Distr.	4
5	300471002	Beam, NS, C6x3x1, Ga12, 3811 mm, G90, P-1P/2P, Distr.	2
6	300346004	Table Leg, Front, C6x3x1, Ga13, 1285 mm, G90, 30° Tilt	2
7	300345002	Beam, EW Splice, C6x3x1, Ga12, 1800 mm, G90, P-2x8, Distr.	4
8	300341002	Table Leg, Back, C6x3x1, Ga12, 2235 mm, G90, 30° Tilt	2
9	300324004	Brace, Lateral, C2.5x2x0.5, Ga13, 1850 mm, G90	4
10	300313XXX*	POST, 3.5" O.D., 0.25" WALL, ASTM A252, 50KSI Y.S	4
11	300232001	Bracket, East-West, Ga 10 , 6 in Beams	8

MAIN COMPONENTS BILL OF MATERIAL FOR 2X6

ITEM NO.	PART NUMBER	DESCRIPTION	QTY.
2	900286001	Foot Bracket, Assembly, PRU Dual Leg, 6" C-Channel Post, 6x150 mm bolt circle Ground Screw, Adjustable N-S	4
3	300475002-MOD For 2X6	Beam, EWW, C6x3x1, Ga12, 3039 mm, G90, P-2x8, Distr. - MOD for 2X6	4
4	300474002	Beam, EWE, C6x3x1, Ga12, 3998 mm, G90, P-2x8, Distr.	4
5	300471002	Beam, NS, C6x3x1, Ga12, 3811 mm, G90, P-1P/2P, Distr.	2
6	300346004	Table Leg, Front, C6x3x1, Ga13, 1285 mm, G90, 30° Tilt	2
7	300345002	Beam, EW Splice, C6x3x1, Ga12, 1800 mm, G90, P-2x8, Distr.	4
8	300341002	Table Leg, Back, C6x3x1, Ga12, 2235 mm, G90, 30° Tilt	2
9	300324004	Brace, Lateral, C2.5x2x0.5, Ga13, 1850 mm, G90	4
10	300313XXX*	POST, 3.5" O.D., 0.25" WALL, ASTM A252, 50KSI Y.S	4
11	300232001	Bracket, East-West, Ga 10 , 6 in Beams	8

* Total embedment depth of the post varies, depending on overburden thickness.

HARDWARE BILL OF MATERIAL FOR 2X8

ITEM NO.	PART NUMBER	DESCRIPTION	QTY.
14	100045010	Bolt, Carriage, 5/16"-18 x 2-1/2", Gr. 5, Magni 565	104
15	100063004	Nut, Hex Flange, Serrated, 5/16"-18, Gr. 5, Magni 565	168
16	100064005	Bolt, Hex Flange, Serrated, 5/16"-18 x 1", Gr. 5, Magni 565	64
17	100014015	Cap Screw, Hex Head, 1/2"-13 x 1-1/2", Gr. 8, HDG	8
18	100011009	Washer, Flat, 3/8" x 1" O.D., HDG	56
19	100033017	Washer, Split Lock, 3/8", HDG	48
20	100015002	Nut, Hex Head, 1/2"-13, A194 Grade-2H, HDG	8
22	400029001	Bonding Washer, WEEB-DSK516-45	20

HARDWARE BILL OF MATERIAL FOR 2X6

ITEM NO.	PART NUMBER	DESCRIPTION	QTY.
12	100064003	Bolt, Hex Flange, Serrated, 1/2"-13 x 1", Gr. 5, Magni 565	48
13	100063002	Nut, Hex Flange, Serrated, 1/2"-13, Gr. 5, Magni 565	48
14	100063001	Nut, Hex Flange, Serrated, 3/8"-16, Gr. 5, Magni 565	80
15	100045009	Bolt, Carriage, 3/8"-16 x 1", Gr. 5, Magni 565	80
16	100033002	Washer, Split Lock, 1/2", HDG	8
17	100015002	Nut, Hex Head, 1/2"-13, A194 Grade-2H, HDG	8
18	100014015	Cap Screw, Hex Head, 1/2"-13 x 1-1/2", Gr. 8, HDG	8
19	100011004	Washer, Flat, 1/2" x 1.375" O.D., HDG	16

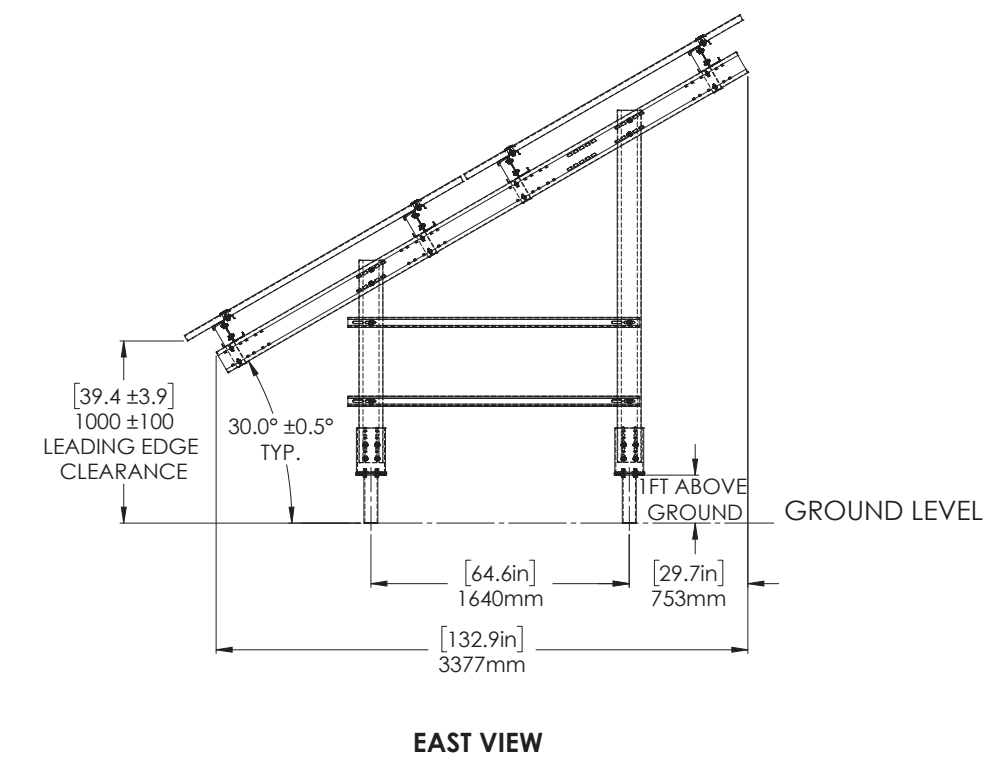

EAST VIEW

THIS DRAWING IS THE PROPERTY OF POLAR RACKING INCLUDING THE PRINCIPLES OF THE DESIGN INVOLVED. IT IS SUBMITTED WITH THE AGREEMENT THAT IT IS NOT TO BE REPRODUCED, SHARED OR DISTRIBUTED IN PART OR IN WHOLE. ACCEPTANCE OF THE DRAWING IS CONSTRUED AS AGREEMENT TO THE ABOVE.

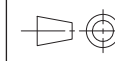

SHEET 4 OF 4

REV.: A

RACK TILT ANGLE (degrees) : 30°

GENERAL NOTES:

- CONTRACTOR TO CONFIRM WITH PV MODULE INSTALLATION MANUAL FOR CLAMPING ZONES TO ENSURE THEY ARE FASTENED PER MODULE REQUIREMENTS.
- ORIGINAL WARRANTY WILL BE MAINTAINED IF ADJUSTMENTS MEET DRAWING SPECIFICATIONS

CLIMATIC DESIGN LOADS
 SNOW AND WIND LOAD COMBINATION FALLING BELOW THE LINE IS ACCEPTABLE

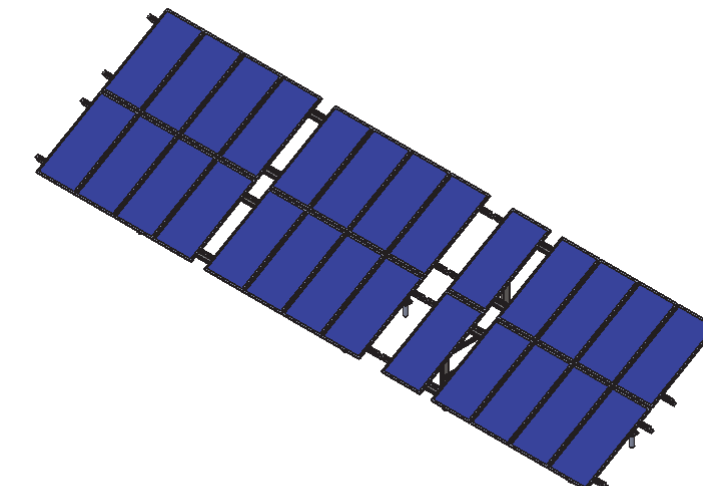
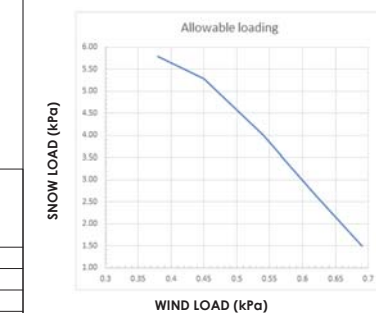

ISOMETRIC VIEW

POST HSS ROUND CROSS SECTION

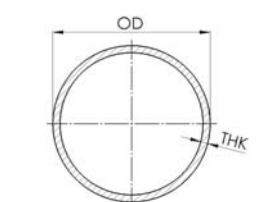

TYPICAL PROFILES

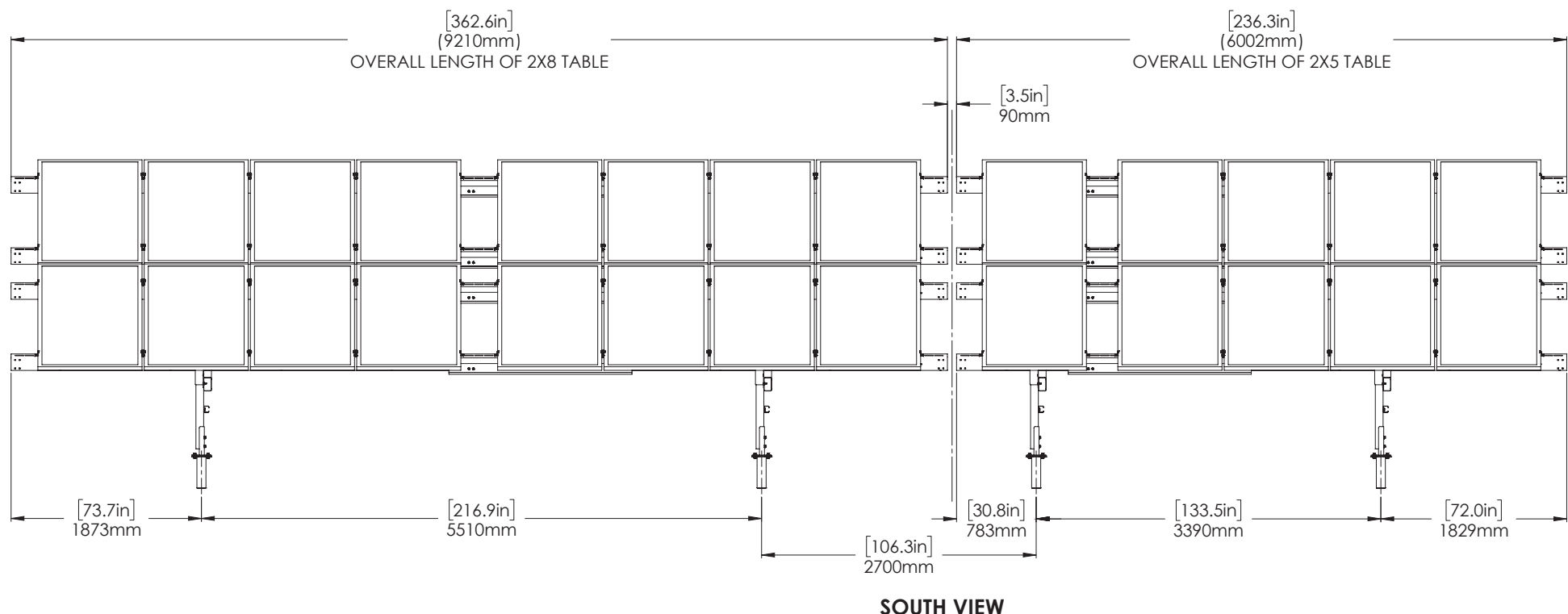
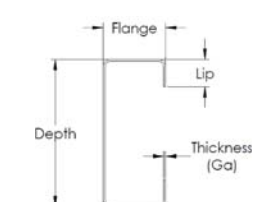

SOUTH VIEW

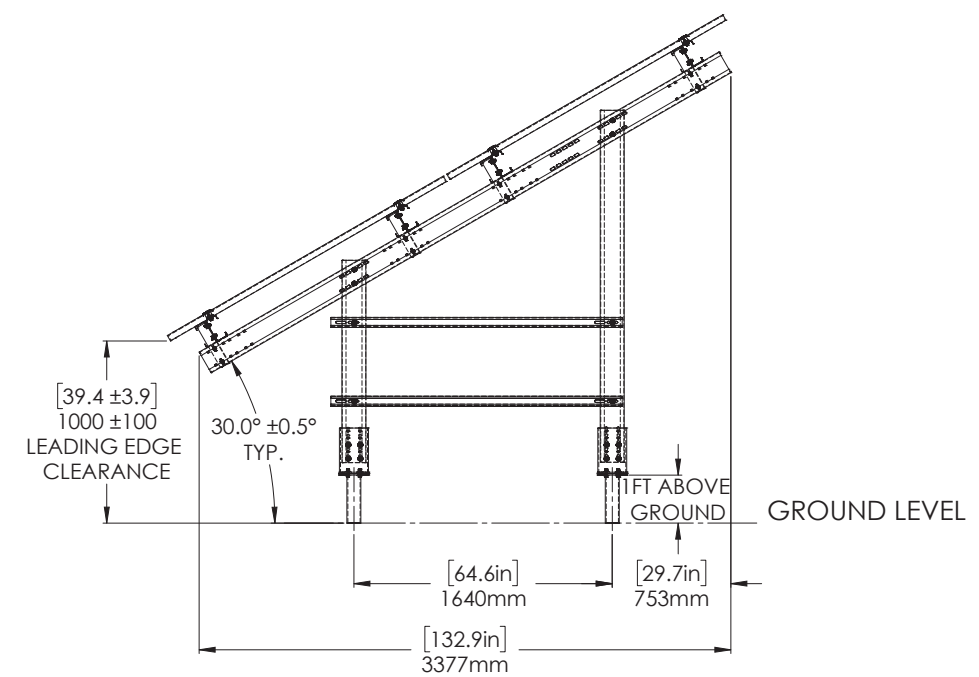

EAST VIEW

MAIN COMPONENTS BILL OF MATERIAL FOR 2X8

ITEM NO.	PART NUMBER	DESCRIPTION	QTY.
2	900286002	Foot Bracket, Assembly, PRU Dual Leg, 6" C-Channel Post, 6x150 mm bolt circle Ground Screw, Adjustable N-S	4
3	300474002	Beam, EWE, C6x3x1, Ga12, 3998 mm, G90, P-2x8, Distr.	4
4	300475002	Beam, EWW, C6x3x1, Ga12, 5202 mm, G90, P-2x8, Distr.	4
5	300471002	Beam, NS, C6x3x1, Ga12, 3811 mm, G90, P-1P/2P, Distr.	2
6	300346004	Table Leg, Front, C6x3x1, Ga13, 1285 mm, G90, 30° Tilt	2
7	300345002	Beam, EW Splice, C6x3x1, Ga12, 1800 mm, G90, P-2x8, Distr.	4
8	300341002	Table Leg, Back, C6x3x1, Ga12, 2235 mm, G90, 30° Tilt	2
9	300324004	Brace, Lateral, C2.5x2x0.5, Ga13, 1850 mm, G90	4
10	300313XXX*	POST, 3.5" O.D., 0.25" WALL, ASTM A252, 50KSI Y.S	4
11	300232001	Bracket, East-West, Ga 10, 6 in Beams	8

HARDWARE BILL OF MATERIAL FOR 2X8

ITEM NO.	PART NUMBER	DESCRIPTION	QTY.
14	100045010	Bolt, Carriage, 5/16"-18 x 2-1/2", Gr. 5, Magni 565	104
15	100063004	Nut, Hex Flange, Serrated, 5/16"-18, Gr. 5, Magni 565	168
16	100064005	Bolt, Hex Flange, Serrated, 5/16"-18 x 1", Gr. 5, Magni 565	64
17	100014015	Cap Screw, Hex Head, 1/2"-13 x 1-1/2", Gr. 8, HDG	8
18	100011009	Washer, Flat, 3/8" x 1" O.D., HDG	56
19	100033017	Washer, Split Lock, 3/8", HDG	48
20	100015002	Nut, Hex Head, 1/2"-13, A194 Grade-2H, HDG	8
22	400029001	Bonding Washer, WEEB-DSK516-45	20

MAIN COMPONENTS BILL OF MATERIAL FOR 2X5

ITEM NO.	PART NUMBER	DESCRIPTION	QTY.
2	900286001	Foot Bracket, Assembly, PRU Dual Leg, 6" C-Channel Post, 6x150 mm bolt circle Ground Screw, Adjustable N-S	4
3	300475002-MOD for 2x5	Beam, EWE, C6x3x1, Ga14, 2x18, 5826mm, 1994x1000x35mm PV	4
4	300474002	Beam, EWE, C6x3x1, Ga12, 3998 mm, G90, P-2x8, Distr.	4
5	300471002	Beam, NS, C6x3x1, Ga12, 3811 mm, G90, P-1P/2P, Distr.	2
6	300346004	Table Leg, Front, C6x3x1, Ga13, 1285 mm, G90, 30° Tilt	2
7	300345002	Beam, EW Splice, C6x3x1, Ga12, 1800 mm, G90, P-2x8, Distr.	4
8	300341002	Table Leg, Back, C6x3x1, Ga12, 2235 mm, G90, 30° Tilt	2
9	300324004	Brace, Lateral, C2.5x2x0.5, Ga13, 1850 mm, G90	4
10	300313XXX*	POST, 3.5" O.D., 0.25" WALL, ASTM A252, 50KSI Y.S	4
11	300232001	Bracket, East-West, Ga 10, 6 in Beams	8

* Total embedment depth of the post varies, depending on overburden thickness.

HARDWARE BILL OF MATERIAL FOR 2X5

ITEM NO.	PART NUMBER	DESCRIPTION	QTY.
12	100064003	Bolt, Hex Flange, Serrated, 1/2"-13 x 1", Gr. 5, Magni 565	48
13	100063002	Nut, Hex Flange, Serrated, 1/2"-13, Gr. 5, Magni 565	48
14	100063001	Nut, Hex Flange, Serrated, 3/8"-16, Gr. 5, Magni 565	80
15	100045009	Bolt, Carriage, 3/8"-16 x 1", Gr. 5, Magni 565	80
16	100033002	Washer, Split Lock, 1/2", HDG	8
17	100015002	Nut, Hex Head, 1/2"-13, A194 Grade-2H, HDG	8
18	100014015	Cap Screw, Hex Head, 1/2"-13 x 1-1/2", Gr. 8, HDG	8
19	100011004	Washer, Flat, 1/2" x 1.375" O.D., HDG	16

PERMIT TO PRACTICE
VAN EE ENGINEERING INC.
 RM SIGNATURE: [Signature]
 RM APEGA ID #: 212064
 DATE: 2021/08/24
PERMIT NUMBER: P015001
 The Associate of Professional Engineers and Geoscientists of Alberta (APEGA)

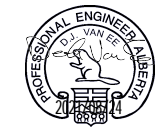

VAN EE ENGINEERING INC.
 STRUCTURAL CONSULTANT
 416-859-2222
 VANEEENGINEERING.CA

PROJECT NAME:
 2X8 CONNECTION WITH 2X5 PRU-D DUAL C-CHANNEL LEG GROUND MOUNT

TITLE:
 PRU-D TABLE FRAME ASSEMBLY,, PORTRAIT, DUAL C-CHANNEL LEG, 30°, MOD. (1950-2300)X(990-1112)X(26-50) mm MODIFIED FOR 2X5

PROJ. NO.: PRU-D
 DWG. BY: VT
 CHECKED BY: MA
 SCALE: NTS

POLAR INTERNAL ASSEMBLY NUMBER:
 900510003

DRAWING NUMBER:
 S-03-1



6889 Rexwood Road, Unit 5, Mississauga, ON L4V 1R2
 TEL: (416) 860-6722 FAX: (519) 258-6664
 www.polarracking.com

THIS DRAWING IS THE PROPERTY OF POLAR RACKING INCLUDING THE PRINCIPLES OF THE DESIGN INVOLVED. IT IS SUBMITTED WITH THE AGREEMENT THAT IT IS NOT TO BE REPRODUCED, SHARED OR DISTRIBUTED IN PART OR IN WHOLE. ACCEPTANCE OF THE DRAWING IS CONSTRUED AS AGREEMENT TO THE ABOVE.

SHEET 1 OF 1
 REV.: **B**

GENERAL NOTES:
 1. CONTRACTOR TO CONFIRM WITH PV MODULE INSTALLATION MANUAL FOR CLAMPING ZONE TO ENSURE THEY ARE FASTENED PER MODULE REQUIREMENTS

PERMIT TO PRACTICE
VAN EE ENGINEERING INC.
 P.M. SIGNATURE: *[Signature]*
 P.M. APEGA ID #: 212064
 DATE: 2021/08/24
PERMIT NUMBER: P015001
 The Associate of Professional Engineers and Geoscientists of Alberta (APEGA)

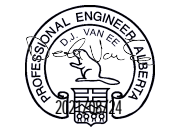

VAN EE ENGINEERING INC.
 VAN EE ENGINEERING
 STRUCTURAL CONSULTANT
 416-859-2222
 VANEEENGINEERING.CA

PROJECT NAME:
 2x8 PRU-D DUAL C-CHANNEL
 GROUND MOUNT

TITLE:
 CONNECTIONS SECTIONS
 AND DETAILS

PROJ. NO.: PRU-D	DWG. BY: MA	CHECKED BY: DV	SCALE: NTS
---------------------	----------------	-------------------	---------------

POLAR INTERNAL ASSEMBLY NUMBER:
 900414000

DRAWING NUMBER:
 S-04

DETAIL G: MID CLAMP TO PV PANELS

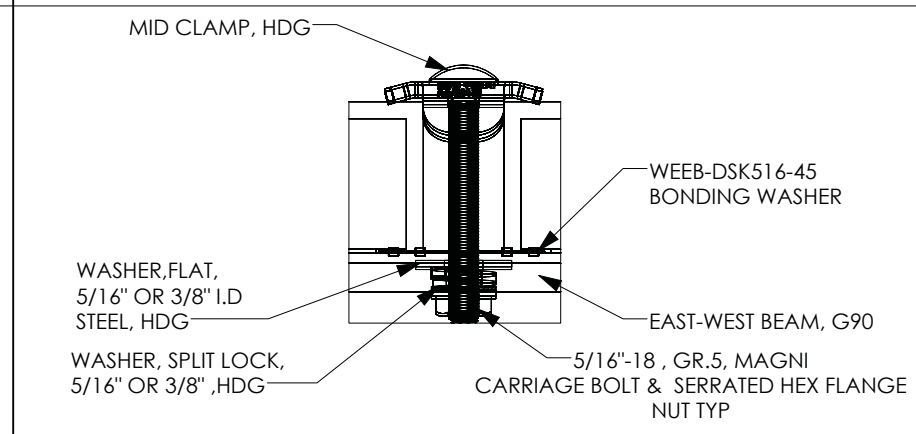

DETAIL H: END CLAMP TO PV PANEL

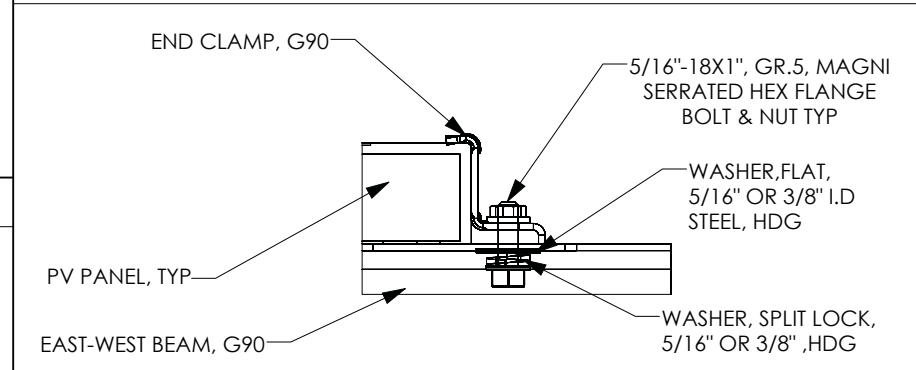

FASTENERS TORQUE

FASTENER SIZE	TIGHTENING TORQUE (ft-lb)
5/16" BOLT	11 ± 1
3/8" BOLT	36 ± 1
1/2" BOLT	55 ⁺² ₋₀

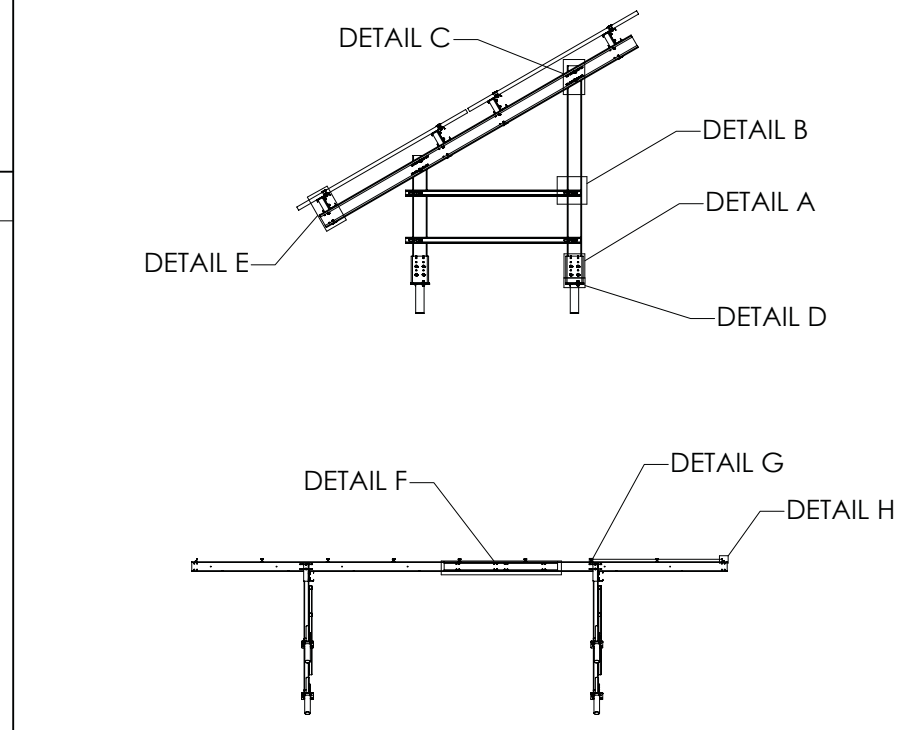

DETAIL D: FOOT BRACKET TO HELICAL PILE

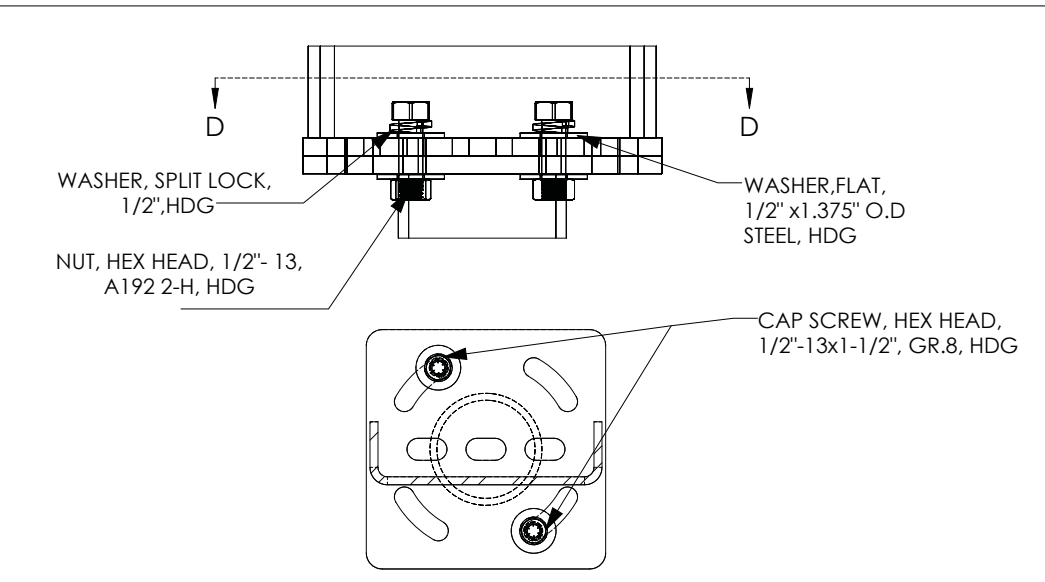

DETAIL A: FOOT BRACKET TO LEG

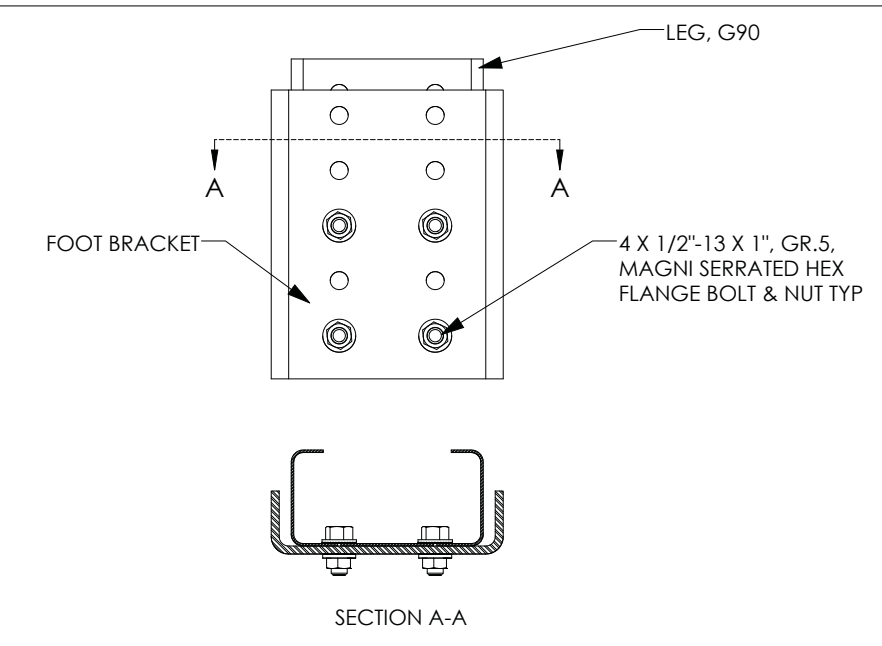

DETAIL E: EAST-WEST BRACKET TO NORTH-SOUTH AND EAST-WEST BEAM

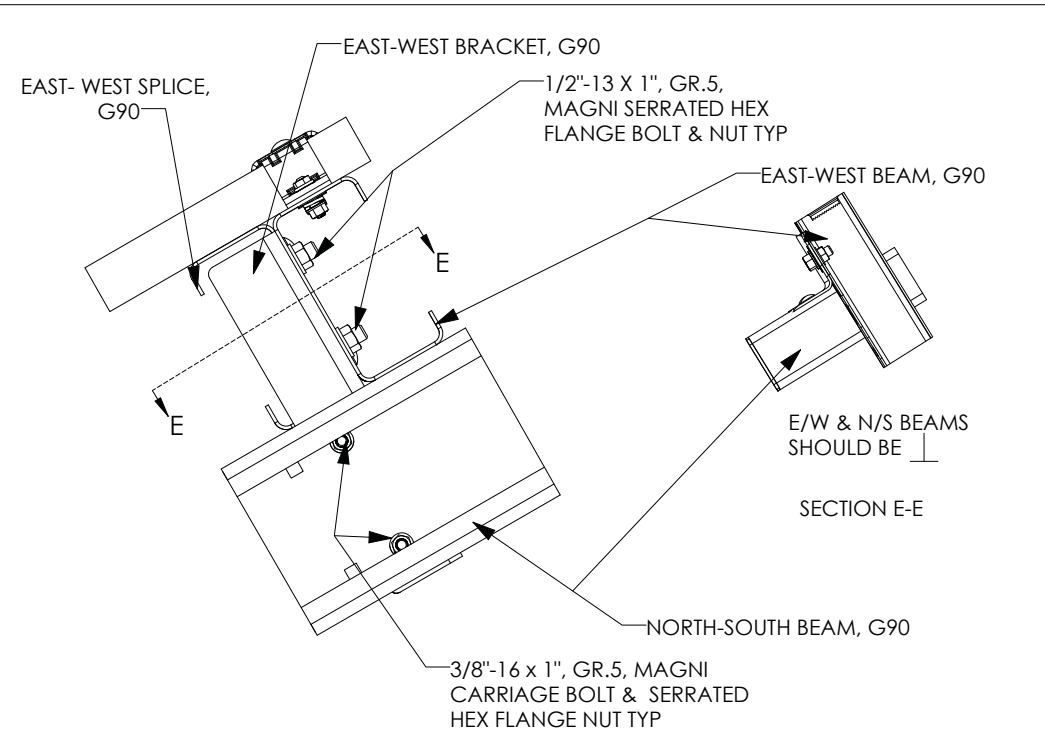

DETAIL B: BRACE TO LEG

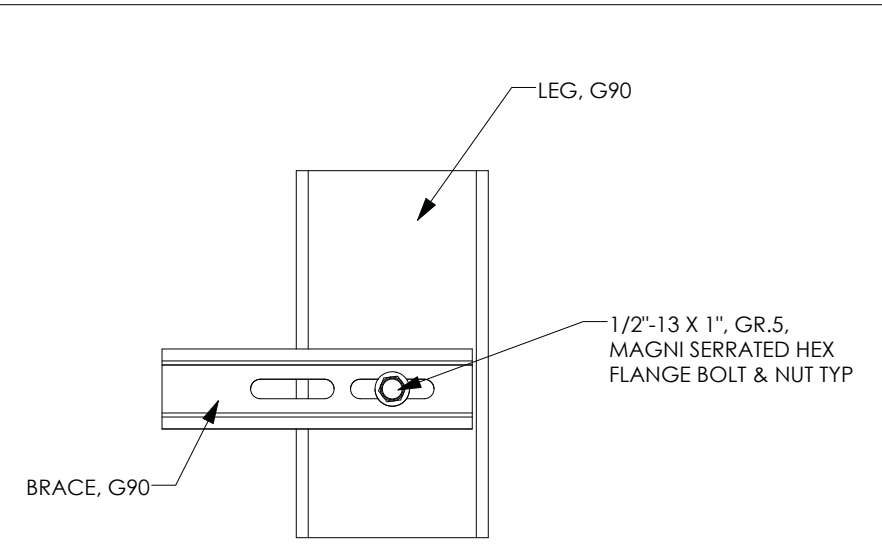

DETAIL F: SPLICE TO EAST-WEST BEAMS

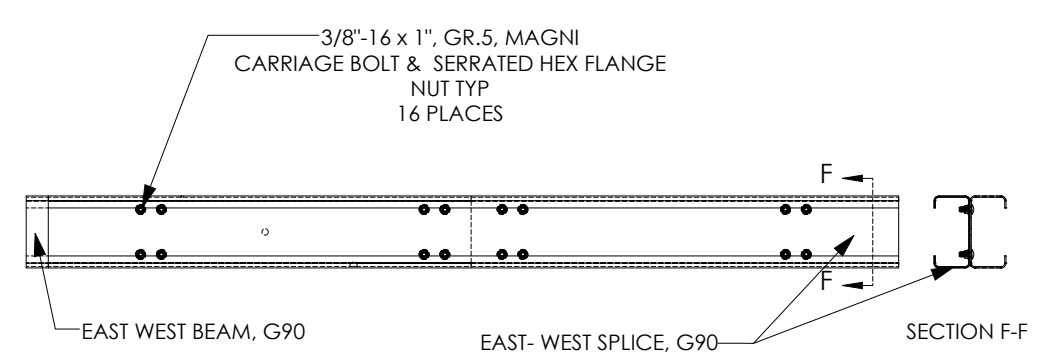

DETAIL C: NORTH-SOUTH BEAM TO LEG

