

A. GENERAL NOTES:

1. THE CONTRACTORS MUST VISIT THE SITE AND BECOME FAMILIARIZED WITH ALL CHARACTERISTICS AFFECTING NEW AND EXISTING CONSTRUCTION ON DRAWINGS AND REPORT ANY DISCREPANCIES TO THE ENGINEER BEFORE PROCEEDING WITH THE WORK, ANY CHANGES, ALTERATIONS, OR REVISIONS MUST BE REPORTED TO THE ENGINEER.
2. ALL MATERIAL AND WORK SHALL CONFORM TO THE ADOPTED CODE REQUIREMENTS OF THE APPLICABLE BUILDING DEPARTMENT.
3. NEITHER THE OWNER NOR CONTRACTOR WILL ENFORCE SAFETY MEASURES OR REGULATIONS. THE CONTRACTOR SHALL DESIGN, CONSTRUCT, AND MAINTAIN ALL SAFETY DEVICES INCLUDING SHORING AND BRACING, AND SHALL BE SOLELY RESPONSIBLE FOR CONFORMING TO ALL LOCAL, STATE AND FEDERAL SAFETY AND HEALTH STANDARDS, LAWS AND REGULATIONS. THE CONTRACT DRAWINGS AND SPECIFICATIONS REPRESENT THE FINISHED STRUCTURE AND DO NOT INDICATE METHODS, PROCEDURES OR SEQUENCE OF CONSTRUCTION. THE CONTRACTOR SHALL TAKE NECESSARY PRECAUTIONS TO MAINTAIN AND INSURE THE INTEGRITY OF THE STRUCTURE DURING CONSTRUCTION. IF A LAWSUIT IS FILED BY ONE OF THE CONTRACTOR'S OR SUBCONTRACTOR'S EMPLOYEES, OR ANY ONE ELSE, THE CONTRACTOR WILL INDEMNIFY, DEFEND AND HOLD THE OWNER AND POLAR RACKING HARMLESS OF ANY AND ALL SUCH CLAIMS.
4. NO PIPES, DUCTS, SLEEVES, CHASE ETC., SHALL BE PLACED CONCRETE PIERS, UNLESS SPECIFICALLY SHOWN OR NOTED. NOR SHALL ANY STRUCTURAL MEMBER BE CUT FOR PIPES, DUCTS, ETC., UNLESS SPECIFICALLY SHOWN. OBTAIN PRIOR WRITTEN APPROVAL FOR INSTALLATION OF ANY ADDITIONAL PIPES, DUCTS, ETC.
5. CONTRACTOR TO CONFIRM WITH PV MODULE INSTALLATION MANUAL FOR CLAMPING ZONES TO ENSURE THEY ARE FASTENED PER MODULE REQUIREMENTS.

B: LOADING PARAMETERS:

DEAD LOAD

TOTAL WEIGHT :0.13 kPa
 STEEL MEMBERS :ACTUAL WEIGHT OF MEMBERS

SNOW AND WIND LOAD COMBINATION FALLING BELOW THE LINE SHOWN IN THE GRAPH BELOW IS ACCEPTABLE

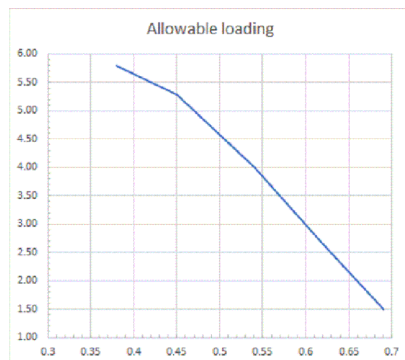

PILE DESIGN: REFER TO PILE DESIGN DOCUMENTS AND DRAWINGS FOR FOUNDATION REACTION LOADS

C: STRUCTURAL STEEL NOTES:

1. RACKING SYSTEM WAS DESIGNED TO SPECIFIED CLIMATIC LOADS AT GROUND LEVEL
2. WIND LOADS HAVE BEEN PRODUCED BASED ON POLAR RACKING PROPRIETARY WIND TUNNEL TESTS RESULTS BY CPP INC.
3. POSITIVE LOADS ARE DOWNWARD I.E COMPRESSIVE LOADS, NEGATIVE LOADS ARE UPLIFT I.E. TENSION LOADS
4. LOADS ARE SPECIFIED VALUES AND MUST BE COMBINED AS PER NBC PART 4
5. REACTION LOADS ASSUME NOMINAL INSTALLATION LOCATIONS
6. LATEST AISI & CSA STANDARD SHALL BE CONSIDERED TO FABRICATE OR DESIGN ANY STEEL COMPONENTS ON RACK
7. INSTALLATION MANUAL SHALL BE USED FOR TORQUE VALUE ON ALL STRUCTURAL CONNECTION POINTS
8. ALL WELDING OF STEEL SHALL BE DONE IN ACCORDANCE WITH THE LATEST VERSION OF CSA W59-03" WELDED STEEL CONSTRUCTION (METAL ARC WELDING)" BY WELDERS CERTIFIED AS PER CSA W47.1
9. SELF-DRILLING SCREWS SHOULD BE INSTALLED WITH NON-IMPACTING VARIABLE SPEED DRILL WITH CLUTCH OUT
10. PV MODULE HARDWARE SHOULD BE TORQUED AND INSPECTED AS PER MODULE MANUFACTURER'S RECOMMENDATIONS
11. DESIGN, FABRICATION AND ERECTION SHALL CONFORM TO THE SPECIFICATIONS AND STANDARDS OF THE CISC CODE OF STANDARD PRACTICE FOR STRUCTURAL STEEL 8TH EDITION (2015).
12. STRUCTURAL STEEL GRADES:
13. SHAPES AND PLATES ASTM A572 OR ASTM A992, GRADE 50 (Fy=50 KSI)
14. WIDE FLANGE BEAMS & COLUMNS ASTM A572 OR ASTM A992, GRADE 50 (Fy=50 KSI)
15. HIGH STRENGTH BOLTS, NUTS, AND WASHER: SAE J429 GR.5; NUT: SAE J429 GR.5, (F436)
16. PRE -GALVANIZED MATERIAL SHALL COMPLY WITH ASTM A653 - G90 MIN.
17. ALL CONNECTIONS NOT SHOWN SHALL CONFORM TO THE "CISC", 8TH EDITION.
18. ALL INSTALLATION WORK SHALL BE DONE IN ACCORDANCE WITH THE FEDERAL AND PROVINCIAL CODES AND STANDARD SPECIFICATIONS.

D: LIGHT GAUGE METAL NOTES:

1. DESIGN, FABRICATION AND ERECTION SHALL CONFORM TO THE SPECIFICATIONS AND STANDARDS OF THE CSA-136-16 "NORTH AMERICAN SPECIFICATION FOR THE DESIGN OF COLD-FORMED STEEL STRUCTURAL MEMBERS.
2. NORTH-SOUTH BEAMS, EAST-WEST BEAMS AND BRACES SHALL BE FORMED TO CHANNEL SHAPE, PUNCHED WEB AND KNURLED FACES, CONFORMING TO ASTM DESIGNATION: A - 446, GRADE 50.
3. NORTH-SOUTH BEAMS, EAST-WEST BEAMS AND BRACES MINIMUM GAUGE THICKNESS ARE SIZED AS SHOWN ON THE RACKING DRAWINGS.



6889 Rexwood Unit 5, Mississauga, ON L4V 1R2
 TEL: 416-860-6722 FAX: 416-860-6719
 www.polarracking.com



00	ISSUED FOR CONSTRUCTION	04MAY21
REV NO.	ISSUANCE	DATE
PROJECT NAME: 2X8 PRU-D GROUND MOUNT		
DRAWING NAME: GENERAL NOTES		
PROJ. NO.:	DWG. BY:	CHKD. BY:
-	VT	MA
		APPR. BY:
		DV
DRAWING NUMBER:		L-01

REV.	DATE	DESCRIPTION	ECO	SIGNATURE
A	14APR21	INITIAL RELEASE	1031	MA
B	15APR21	ISSUED FOR CONSTRUCTION	1031	MA
C	28APR21	PART DESCRIPTIONS REVISED	1031	MA



6889 Rexwood Road, Unit 5, Mississauga, ON L4V 1R2
 TEL: (416) 860-6722 FAX: (519) 258-6664
 www.polarracking.com

THIS DRAWING IS THE PROPERTY OF POLAR RACKING INCLUDING THE PRINCIPLES OF THE DESIGN INVOLVED. IT IS SUBMITTED WITH THE AGREEMENT THAT IT IS NOT TO BE REPRODUCED, SHARED OR DISTRIBUTED IN PART OR IN WHOLE. ACCEPTANCE OF THE DRAWING IS CONSTRUED AS AGREEMENT TO THE ABOVE.

SHEET 1 OF 1
 REV.: C

RACK TILT ANGLE (degrees) : 30°

GENERAL NOTES:

1. CONTRACTOR TO CONFIRM WITH PV MODULE INSTALLATION MANUAL FOR CLAMPING ZONES TO ENSURE THEY ARE FASTENED PER MODULE REQUIREMENTS

CLIMATIC DESIGN LOADS
 SNOW AND WIND LOAD COMBINATION FALLING BELOW THE LINE IS ACCEPTABLE

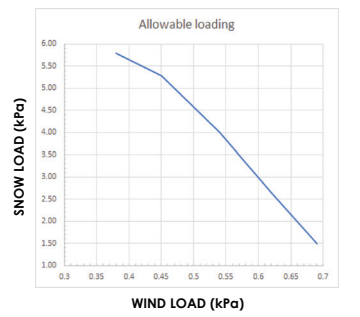

VAN EE ENGINEERING INC.
 VAN EE ENGINEERING
 STRUCTURAL CONSULTANT
 416-659-2222
 VANEENGINEERING.CA

PROJECT NAME:
2X8 PRU-D DUAL C-CHANNEL GROUND MOUNT

TITLE:
**RACKING ASSEMBLY DETAILS
 PRU-D 2X8
 MODULE RANGE
 990-1030mm PV WIDTH**

PROJ. NO.: PRU-D
 DWG. BY: VT
 CHECKED BY: MA
 SCALE: NTS

POLAR INTERNAL ASSEMBLY NUMBER:
 900489000

DRAWING NUMBER:
S-01

TABLE 1 (300104000 - PRG, Clamp, Top)

PART NO.	DESCRIPTION	PV HEIGHT RANGE (mm)
300104001	PRG, Clamp, Top, 31-35 mm Module Height, 40 mm, Ga12, G90	31 - 35
300104002	PRG, Clamp, Top, 37-40 mm Module Height, 40 mm, Ga12, G90	37 - 40
300104003	PRG, Clamp, Top, 43-46 mm Module Height, 40 mm, Ga12, G90	43 - 46
300104004	PRG, Clamp, Top, 47-50 mm Module Height, 40 mm, Ga12, G90	47 - 50
300104005	PRG, Clamp, Top, 26-30 mm Module Height, 40 mm, Ga12, G90	26 - 30

TABLE 2 (100045000 - Bolt, Carriage, Steel)

PART NO.	DESCRIPTION	PV HEIGHT RANGE (mm)
100045010	Bolt, Carriage, 5/16"-18 x 2-1/2", Gr.5, Magni 565	26 - 40
100045020	Bolt, Carriage, 5/16"-18 x 3", Gr.5, Magni 565	43 - 50

2X8 TABLE CONFIGURATION DETAILS

ASSEMBLY NUMBER	CLAMP, TOP PART NUMBER	BOLT, CARRIAGE PART NUMBER	TABLE CONFIGURATION
900489001	300104001	100045010	PRU-D Table Assembly, 2x8, Portrait, Dual C-Channel Leg, 30°, Mod. (1950-2300)x(990-1030)x(31-35) mm
900489002	300104002	100045010	PRU-D Table Assembly, 2x8, Portrait, Dual C-Channel Leg, 30°, Mod. (1950-2300)x(990-1030)x(37-40) mm
900489003	300104003	100045020	PRU-D Table Assembly, 2x8, Portrait, Dual C-Channel Leg, 30°, Mod. (1950-2300)x(990-1030)x(43-46) mm
900489004	300104004	100045020	PRU-D Table Assembly, 2x8, Portrait, Dual C-Channel Leg, 30°, Mod. (1950-2300)x(990-1030)x(47-50) mm
900489005	300104005	100045010	PRU-D Table Assembly, 2x8, Portrait, Dual C-Channel Leg, 30°, Mod. (1950-2300)x(990-1030)x(26-30) mm

TABLE -3 PANEL SPACING TABLE

Panel Width	Fits?(Y/N)	A (mm)	B (21.34-27mm)
990	Y	307	21.34
991	Y	368	21.34
992	Y	361	21.34
993	Y	361	21.34
994	Y	358	21.34
995	Y	358	21.34
996	Y	357	21.34
997	Y	377	21.34
998	Y	377	21.34
999	Y	376	21.34
1000	Y	388	21.34
1001	Y	387	21.34
1002	Y	289	21.34
1003	Y	288	21.34
1004	Y	287	21.34
1005	Y	286	21.34
1006	Y	285	21.34
1007	Y	284	21.34
1008	Y	283	21.34
1009	Y	283	21.34
1010	Y	282	21.34
1011	Y	279	21.34
1012	Y	360	21.34
1013	Y	357	21.34
1014	Y	356	21.34
1015	Y	356	21.34
1016	Y	355	21.34
1017	Y	355	21.34
1018	Y	354	21.34
1019	Y	352	21.34
1020	Y	406	21.34
1021	Y	306	21.34
1022	Y	306	21.34
1023	Y	304	21.34
1024	Y	197	21.34
1025	Y	323	21.34
1026	Y	322	21.34
1027	Y	322	21.34
1028	Y	321	21.34
1029	Y	321	21.34
1030	Y	318	21.34

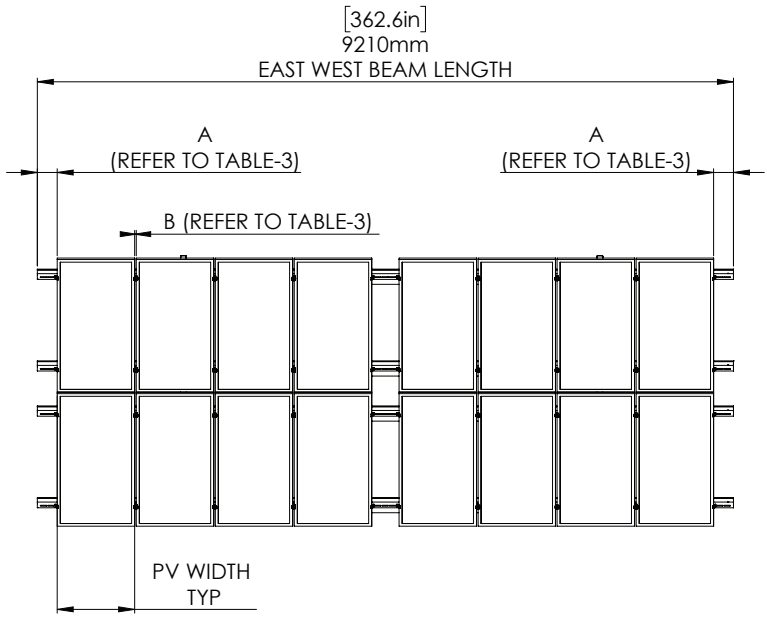

TOP VIEW

*FOR CLAMPING REQUIREMENTS, REFER TO GENERAL NOTES 1

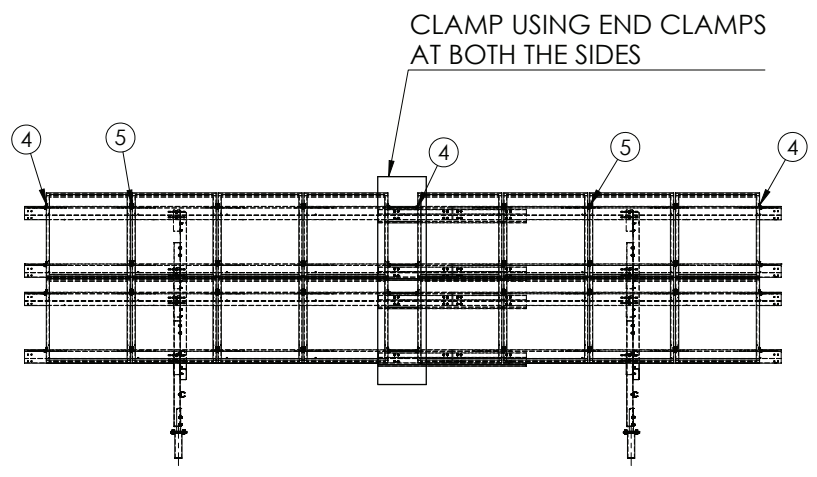

SOUTH VIEW

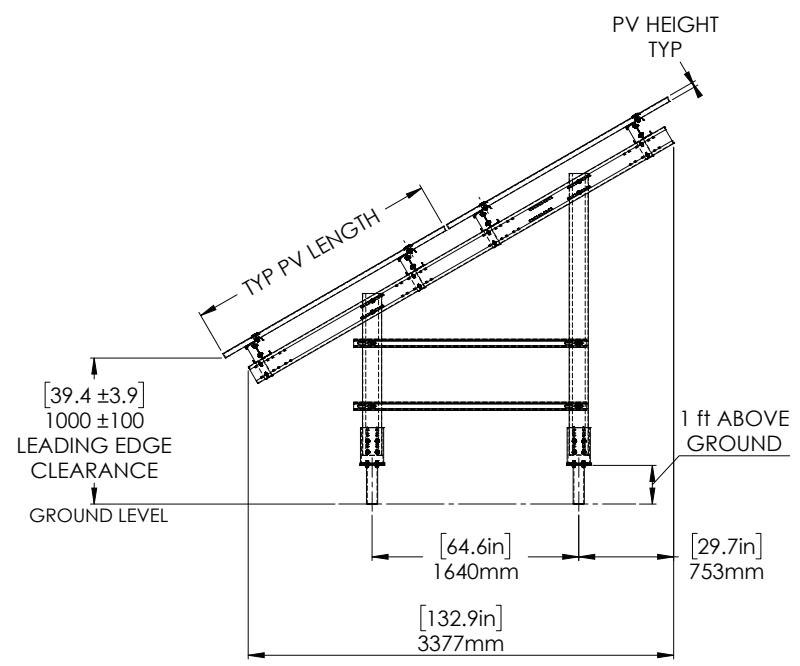

EAST VIEW

BILL OF MATERIAL

ITEM NO.	PART NUMBER	DESCRIPTION	QTY.
1	900495001	PRU-D Table Frame Assembly, 2x8, Portrait, Dual C-Channel Leg, 30°, Mod. (1950-2300)x(990-1112)x(26-50) mm	1
2	400029001	Bonding Washer, WEEB-DSK516-45	20
3	400026XXX	72 Cells Module (Not Polar Supply)	16
4	30010400X	PRG, Clamp, Top, XX-XX mm Module Height, 40mm, Ga12, G90	16
5	300012005	Clamp, Intermodule, Serrated, 9 mm Sq. Hole, 40 mm, Ga10, HDG	24
6	100064005	Bolt, Hex Flange, Serrated, 5/16"-18 x 1", Gr. 5, Magni 565	16
7	100063004	Nut, Hex Flange, Serrated, 5/16"-18, Gr. 5, Magni 565	40
8	1000450XX	Bolt, Carriage, 5/16"-18 x XX", Gr. 5, Magni 565, See Table 2	24
9	100033017	Washer, Split Lock, 3/8", HDG	40
10	100011009	Washer, Flat, 3/8" x 1" O.D., HDG	40

REV.	DATE	DESCRIPTION	ECO	SIGNATURE
A	14APR21	INITIAL RELEASE	1031	MA
B	15APR21	ISSUED FOR CONSTRUCTION	1031	MA
C	28APR21	PART DESCRIPTIONS UPDATED	1031	MA



6889 Rexwood Road, Unit 5, Mississauga, ON L4V 1R2
 TEL: (416) 860-6722 FAX: (519) 258-6664
 www.polarracking.com

THIS DRAWING IS THE PROPERTY OF POLAR RACKING INCLUDING THE PRINCIPLES OF THE DESIGN INVOLVED. IT IS SUBMITTED WITH THE AGREEMENT THAT IT IS NOT TO BE REPRODUCED, SHARED OR DISTRIBUTED IN PART OR IN WHOLE. ACCEPTANCE OF THE DRAWING IS CONSTRUED AS AGREEMENT TO THE ABOVE.

SHEET 1 OF 1
 REV.: C

RACK TILT ANGLE (degrees) : 30°

GENERAL NOTES:

1. CONTRACTOR TO CONFIRM WITH PV MODULE INSTALLATION MANUAL FOR CLAMPING ZONES TO ENSURE THEY ARE FASTENED PER MODULE REQUIREMENTS

CLIMATIC DESIGN LOADS
 SNOW AND WIND LOAD COMBINATION FALLING BELOW THE LINE IS ACCEPTABLE

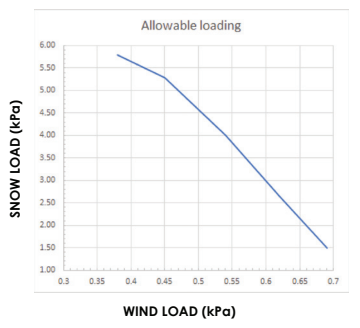

VAN EE ENGINEERING INC
 VAN EE ENGINEERING
 STRUCTURAL CONSULTANT
 416-659-2222
 VANEENGINEERING.CA

PROJECT NAME:
 2X8 PRU-D DUAL C-CHANNEL GROUND MOUNT

TITLE:
 RACKING ASSEMBLY DETAILS
 PRU-D 2X8
 MODULE RANGE
 1031-1112mm PV WIDTH

PROJ. NO.:	DWG. BY:	CHECKED. BY:	SCALE:
PRU-D	VT	MA	NTS

POLAR INTERNAL ASSEMBLY NUMBER:
 900490000

DRAWING NUMBER:
 S-02

TABLE 1 (300104000 - PRG, Clamp, Top)

PART NO.	DESCRIPTION	PV HEIGHT RANGE (mm)
300104001	PRG, Clamp, Top, 31-35 mm Module Height, 40 mm, Ga12, G90	31 - 35
300104002	PRG, Clamp, Top, 37-40 mm Module Height, 40 mm, Ga12, G90	37 - 40
300104003	PRG, Clamp, Top, 43-46 mm Module Height, 40 mm, Ga12, G90	43 - 46
300104004	PRG, Clamp, Top, 47-50 mm Module Height, 40 mm, Ga12, G90	47 - 50
300104005	PRG, Clamp, Top, 26-30 mm Module Height, 40 mm, Ga12, G90	26 - 30

TABLE 2 (100045000 - Bolt, Carriage, Steel)

PART NO.	DESCRIPTION	PV HEIGHT RANGE (mm)
100045010	Bolt, Carriage, 5/16"-18 x 2-1/2", Gr.5, Magni 565	26 - 40
100045020	Bolt, Carriage, 5/16"-18 x 3", Gr.5, Magni 565	43 - 50

2X8 TABLE CONFIGURATION DETAILS

ASSEMBLY NUMBER	CLAMP, TOP PART NUMBER	BOLT, CARRIAGE PART NUMBER	TABLE CONFIGURATION
900490001	300104001	100045010	PRU-D Table Assembly, 2x8, Portrait, Dual C-Channel Leg, 30°, Mod. (1950-2300)x(1031-1112)x(31-35) mm
900490002	300104002	100045010	PRU-D Table Assembly, 2x8, Portrait, Dual C-Channel Leg, 30°, Mod. (1950-2300)x(1031-1112)x(37-40) mm
900490003	300104003	100045020	PRU-D Table Assembly, 2x8, Portrait, Dual C-Channel Leg, 30°, Mod. (1950-2300)x(1031-1112)x(43-46) mm
900490004	300104004	100045020	PRU-D Table Assembly, 2x8, Portrait, Dual C-Channel Leg, 30°, Mod. (1950-2300)x(1031-1112)x(47-50) mm
900490005	300104005	100045010	PRU-D Table Assembly, 2x8, Portrait, Dual C-Channel Leg, 30°, Mod. (1950-2300)x(1031-1112)x(26-30) mm

TABLE -3-A PANEL SPACING TABLE

Panel Width	Fits?(Y/N)	A (mm)	B (21.34-27mm)
1031	Y	401.5	26.00
1032	Y	475.5	24.50
1033	Y	473.5	24.00
1034	Y	472.5	23.00
1035	Y	472.0	22.00
1036	Y	471.5	21.34
1037	Y	418.5	27.00
1038	Y	418.0	26.00
1039	Y	421.5	24.00
1040	Y	420.0	23.00
1041	Y	420.5	22.00
1042	Y	419.0	21.34
1043	Y	414.0	21.34
1044	Y	409.5	21.34
1045	Y	426.5	27.00
1046	Y	426.5	26.00
1047	Y	426.0	25.00
1048	Y	425.5	24.00
1049	Y	425.0	23.00
1050	Y	424.5	22.00
1051	Y	424.0	21.34
1052	Y	423.5	21.34
1053	Y	423.0	21.34
1054	Y	422.5	21.34
1055	Y	422.0	21.34
1056	Y	421.5	21.34
1057	Y	421.0	21.34
1058	Y	420.5	21.34
1059	Y	420.0	21.34
1060	Y	355.0	21.34
1061	Y	354.5	21.34
1062	Y	354.0	21.34
1063	Y	353.5	21.34
1064	Y	353.0	21.34
1065	Y	352.5	21.34
1066	Y	352.0	21.34
1067	Y	351.5	21.34
1068	Y	351.0	21.34
1069	Y	350.5	21.34
1070	N	-	-
1071	N	-	-
1072	N	-	-
1073	N	-	-
1074	Y	270.5	27.00

TABLE -3-B PANEL SPACING TABLE

Panel Width	Fits?(Y/N)	A (mm)	B (21.34-27mm)
1075	Y	270.0	26.00
1076	Y	212.0	25.00
1077	Y	212.5	24.00
1078	Y	212.0	23.00
1079	Y	211.5	22.00
1080	Y	232.5	25.00
1081	Y	232.0	24.00
1082	Y	231.5	23.00
1083	Y	231.0	22.00
1084	Y	229.5	21.34
1085	Y	202.0	21.34
1086	Y	199.0	21.34
1087	Y	190.5	27.00
1088	Y	190.0	26.00
1089	Y	189.5	25.00
1090	Y	189.0	24.00
1091	Y	188.5	23.00
1092	Y	188.0	22.00
1093	Y	187.5	21.34
1094	Y	185.0	21.34
1095	Y	133.0	26.00
1096	Y	132.5	25.00
1097	Y	132.0	24.00
1098	Y	97.0	21.34
1099	Y	94.0	21.34
1100	Y	89.0	21.34
1101	Y	91.0	25.00
1102	Y	90.0	24.00
1103	Y	87.0	24.00
1104	Y	87.0	24.00
1105	Y	87.0	21.34
1106	Y	87.0	21.34
1107	Y	87.0	21.34
1108	Y	60.0	21.34
1109	Y	60.0	21.34
1110	Y	60.0	21.34
1111	Y	60.0	21.34
1112	Y	60.0	21.34

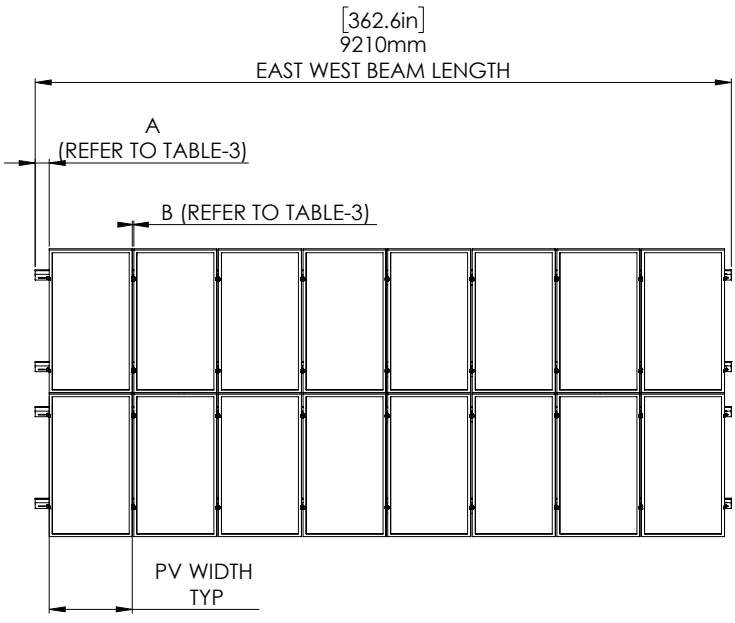

TOP VIEW

*FOR CLAMPING REQUIREMENTS, REFER TO GENERAL NOTES 1

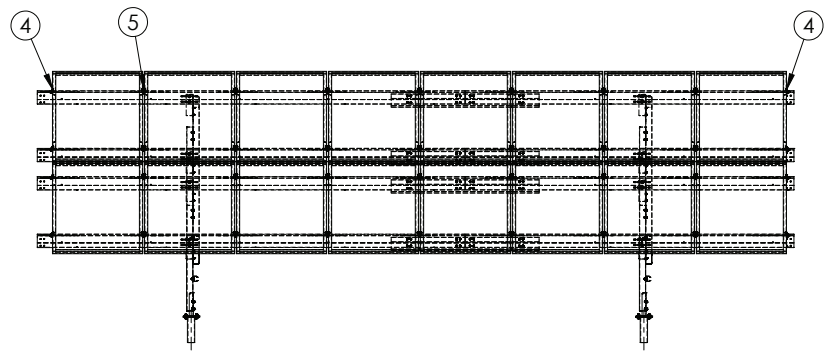

SOUTH VIEW

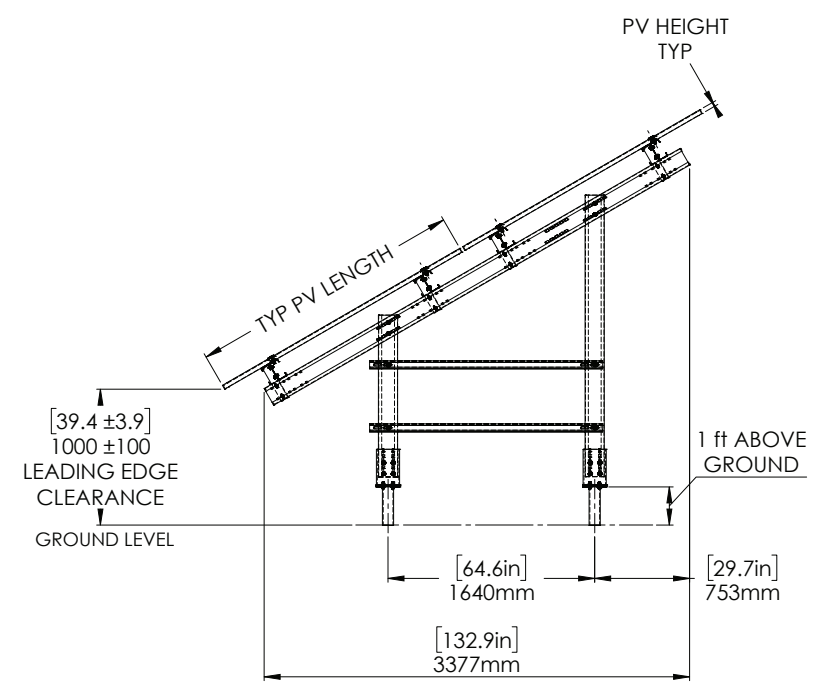

EAST VIEW

BILL OF MATERIAL

ITEM NO.	PART NUMBER	DESCRIPTION	QTY.
1	900495001	PRU-D Table Frame Assembly, 2x8, Portrait, Dual C-Channel Leg, 30°, Mod. (1950-2300)x(990-1112)x(26-50) mm	1
2	400029001	Bonding Washer, WEEB-DSK516-45	18
3	400026XXX	72 Cells Module (Not Polar Supply)	16
4	30010400X	PRG, Clamp, Top, XX-XX mm Module Height, 40mm, Ga12, G90, See Table 1	8
5	300012005	Clamp, Intermodule, Serrated, 9 mm Sq. Hole, 40 mm, Ga10, HDG	28
6	100064005	Bolt, Hex Flange, Serrated, 5/16"-18 x 1", Gr. 5, Magni 565	8
7	100063004	Nut, Hex Flange, Serrated, 5/16"-18, Gr. 5, Magni 565	36
8	1000450XX	Bolt, Carriage, 5/16"-18 x XX", Gr. 5, Magni 565, See Table 2	28
9	100033017	Washer, Split Lock, 3/8", HDG	36
10	100011009	Washer, Flat, 3/8" x 1" O.D., HDG	36

REV.	DATE	DESCRIPTION	ECO	SIGNATURE
A	14APR21	INITIAL RELEASE	1031	MA
B	15APR21	ISSUED FOR CONSTRUCTION	1031	MA
C	29APR21	PART DESCRIPTION UPDATED	1031	MA



6889 Rexwood Road, Unit 5, Mississauga, ON L4V 1R2
 TEL: (416) 860-6722 FAX: (519) 258-6664
 www.polarracking.com

THIS DRAWING IS THE PROPERTY OF POLAR RACKING INCLUDING THE PRINCIPLES OF THE DESIGN INVOLVED. IT IS SUBMITTED WITH THE AGREEMENT THAT IT IS NOT TO BE REPRODUCED, SHARED OR DISTRIBUTED IN PART OR IN WHOLE. ACCEPTANCE OF THE DRAWING IS CONSTRUED AS AGREEMENT TO THE ABOVE.

SHEET 1 OF 1
 REV.:
C

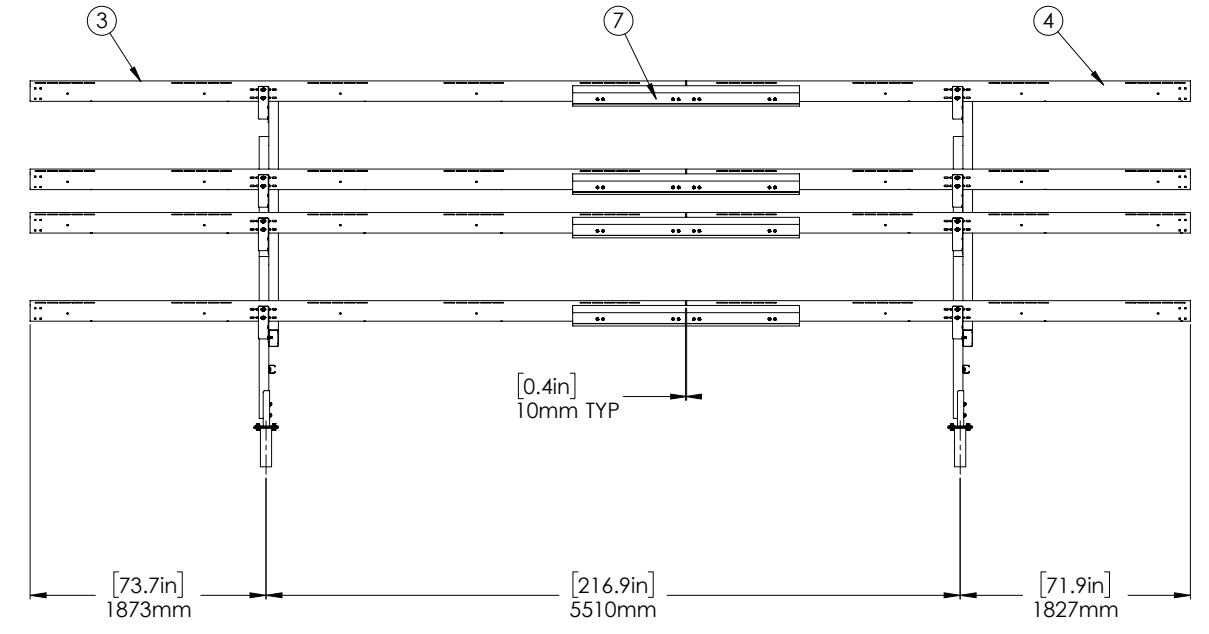

SOUTH VIEW



ISOMETRIC VIEW

POST HSS ROUND CROSS SECTION

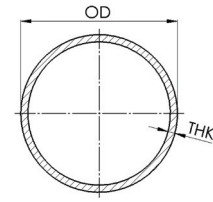

TYPICAL PROFILES

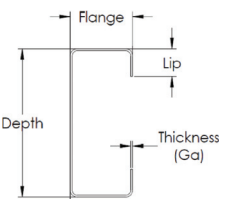

PART	PROFILE (in.) Depth x Flange x Lip	MIN. THICKNESS (MM)	MATERIAL Fy (ksi)
POST	3.5" OD	6.35	50
TABLE LEG (FRONT)	6 X 3 X 1	2.35	50
TABLE LEG (BACK)	6 X 3 X 1	2.15	55
EAST-WEST BEAM	6 X 3 X 1	2.75	50
NORTH-SOUTH BEAM	6 X 3 X 1	2.50	60
BRACE	2.5 X 2.0 X 0.5	2.50	50
		2.35	50
		2.15	55

RACK TILT ANGLE (degrees) : 30°

GENERAL NOTES:

1. CONTRACTOR TO CONFIRM WITH PV MODULE INSTALLATION MANUAL FOR CLAMPING ZONES TO ENSURE THEY ARE FASTENED PER MODULE REQUIREMENTS

CLIMATIC DESIGN LOADS
 SNOW AND WIND LOAD COMBINATION FALLING BELOW THE LINE IS ACCEPTABLE

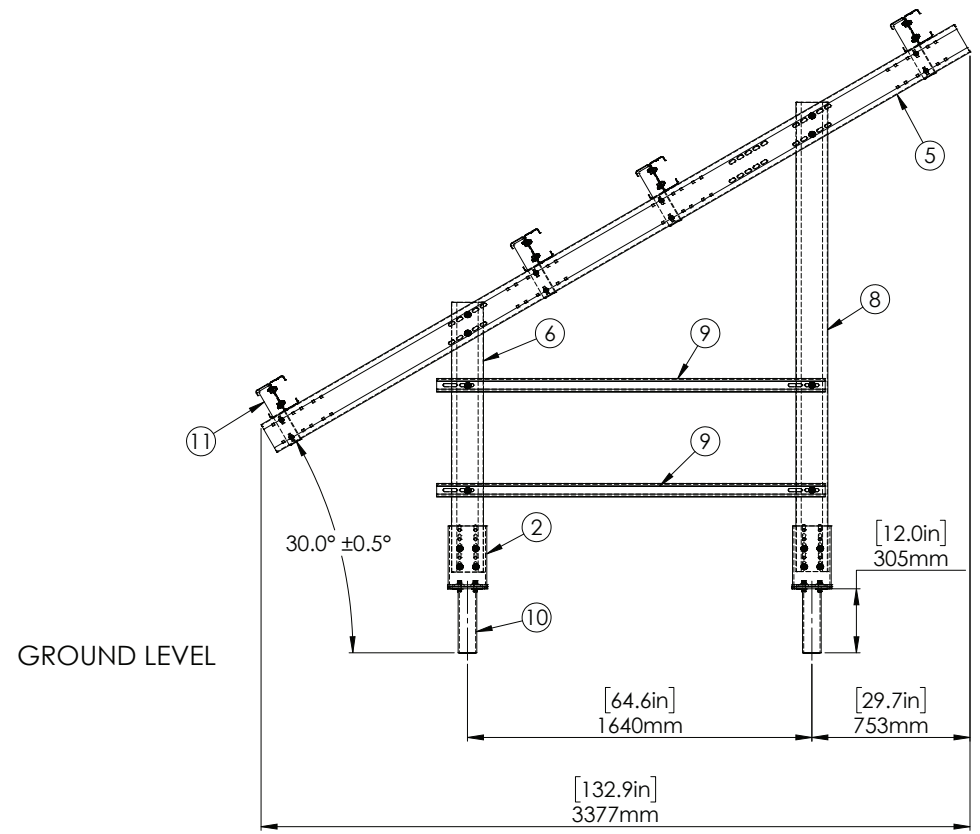
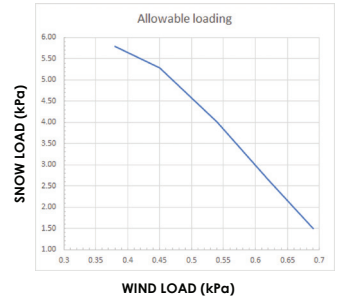

EAST VIEW

MAIN COMPONENTS BILL OF MATERIAL

ITEM NO.	PART NUMBER	DESCRIPTION	QTY.
2	900286001	Foot Bracket Assembly, 6" Beam, 4x150mm Bolt Circle, HDG	4
3	300475002	Beam, EWW, C6x3x1, Ga12, 5202 mm, G90, P-2x8, Distr.	4
4	300474002	Beam, EWE, C6x3x1, Ga12, 3998 mm, G90, P-2x8, Distr.	4
5	300471002	Beam, NS, C6x3x1, Ga12, 3811 mm, G90, P-1P/2P, Distr.	2
6	300346004	Table Leg, Front, C6x3x1, Ga13, 1285 mm, G90, 30° Tilt	2
7	300345002	Beam, EW Splice, C6x3x1, Ga12, 1800 mm, G90, P-2x8, Distr.	4
8	300341002	Table Leg, Back, C6x3x1, Ga12, 2235 mm, G90, 30° Tilt	2
9	300324004	Brace, Lateral, C2.5x2x0.5, Ga13, 1850 mm, G90	4
10	300313XXX*	POST, 3.5" O.D., 0.25"WALL, ASTM A252, 50ksi Y.S.	4
11	300232001	Bracket, East-West, 6" Beam, Ga10, HDG	8

* Total embedment depth of the post varies, depending on overburden thickness.

HARDWARE BILL OF MATERIAL

ITEM NO.	PART NUMBER	DESCRIPTION	QTY.
12	100064003	Bolt, Hex Flange, Serrated, 1/2"-13 x 1", Gr. 5, Magni 565	48
13	100063002	Nut, Hex Flange, Serrated, 1/2"-13, Gr. 5, Magni 565	48
14	100063001	Nut, Hex Flange, Serrated, 3/8"-16, Gr. 5, Magni 565	80
15	100045009	Bolt, Carriage, 3/8"-16 x 1", Gr. 5, Magni 565	80
16	100033002	Washer, Split Lock, 1/2", HDG	8
17	100015002	Nut, Hex Head, 1/2"-13, A194 Grade-2H, HDG	8
18	100014015	Cap Screw, Hex Head, 1/2"-13 x 1-1/2", Gr. 8, HDG	8
19	100011004	Washer, Flat, 1/2"x1.375" O.D., HDG	16



PROJECT NAME:
 2X8 PRU-D DUAL C-CHANNEL LEG GROUND MOUNT

TITLE:
 PRU-D TABLE FRAME ASSEMBLY, 2X8, PORTRAIT, DUAL C-CHANNEL LEG, 30°, MOD. (1950-2300)X(990-1112)X(26-50) mm

PROJ. NO.: PRU-D
 DWG. BY: VT
 CHECKED BY: MA
 SCALE: NTS

POLAR INTERNAL ASSEMBLY NUMBER:
 900495001

DRAWING NUMBER:
 S-03