

INSTALLATION MANUAL

RT-APEX

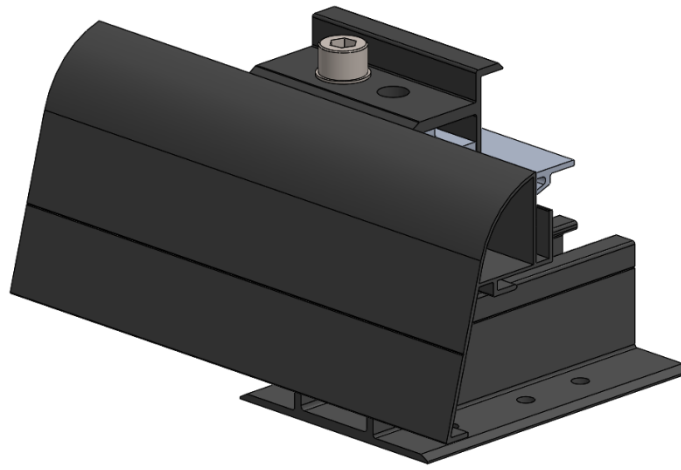

10620 Trenea St, Suite 230
San Diego, California 92131
TEL (858) 935-6064



Contents

• Introduction	-----	1
• System Fire Ratings	-----	2
• Bonding/Grounding of Modules	-----	2
• Periodic Inspection	-----	2
• Tools & Supplies Required for Assembly	-----	3
• Moisture Content	-----	4
• Installation Safety	-----	4
• Distance from roof to bottom of PV module	-----	5
PART A: Materials	-----	6
PART B: Landscape Layout	-----	11
1. Installation of Brackets		
(1) Bracket Layout		
a) Rafter Installation	-----	11
b) Deck Installation	-----	14
(2) Bracket Installation	-----	17
2. Installation of Panels	-----	27
3. Eaves Cover: Skirt (Optional)	-----	36
4. Eaves Cover Joint: Skirt Splice (Optional)	-----	38
5. Skirt End Cap (Optional)	-----	39
6. Side Screw (Optional)	-----	40
7. SUMO Clip (Optional)	-----	41
PART C: Splice Installation	-----	42
1. Installation of Brackets		
(1) Bracket Layout		
a) Rafter Installation	-----	42
b) Deck Installation	-----	43
c) Splice Installation Area	-----	45
(2) Floating Splice Installation	-----	47
(3) End Splice Installation	-----	49
(4) Middle Splice Installation	-----	50
(5) Upper End Splice Installation	-----	53

PART D: Portrait Layout	-----	56
1. Installation of Brackets		
(1) Bracket Layout		
a) Rafter Installation	-----	56
b) Deck Installation	-----	58
PART E: Electrical Setup	-----	61
1. Cable Management Options	-----	61
2. Grounding Setup	-----	62
3. Bonding Path Diagrams	-----	64
ADDENDUM: Installation Instruction for Metal Roofing		
1. Requirements	-----	72
2. Marking	-----	73
3. Bracket Installation	-----	74
ADDENDUM: Installation Instruction for Classic rib Metal Roofing		
1. Requirements	-----	78
2. Marking	-----	79
3. Bracket Installation	-----	81
ADDENDUM: Installation Instruction for Composite Slate		
1. Requirements	-----	84
2. Marking	-----	84
3. Bracket Installation	-----	85
APPENDIX:		
List of PV Modules compatible with this Racking System	---	87

Introduction

Please review this manual thoroughly before installing your Roof-Tech system. Aside from reading this manual, please review the PE Stamped Engineering Certification for the Roof-Tech APEX Solar products for your State. The Roof Tech Structural Stamped letters are prepared based on 2 layers of asphalt shingles. This manual provides supporting documentation for RT-APEX.

We recommend installer to carefully review the instructions provided by the PV module manufacturer and become acquainted with OSHA's safety procedures prior to installing the PV system.

The installer is solely responsible for:

- Handling and installing the PV modules according to the manufacturer's instruction, with special attention for the suggested clamping locations on the frame.
- Complying with all applicable local or national building codes, standards and industry best practices including any code that may supersede this manual.
- Ensuring that Roof-Tech's and other products are appropriate for the particular installation and the installation location.
- Ensuring that the roof, its rafters, connections, and other structural support members can support the array under all code level loading conditions.
- Using only Roof-Tech parts and installer-supplied parts as specified by Roof-Tech. (Substitution of parts may void the warranty and invalidate the letters of certification.)
- Verifying the strength of any alternate mounting devices used in lieu of the anchoring screws.
- Maintaining the waterproof integrity of the roof.



Attention

To maintain the flashing performance, avoid installation when the temperature is below 22F or above 176F. RT Butyl must be installed on a dry surface.

- Ensuring safe installation of all electrical and mechanical aspects of the PV array.
- Ensuring correct and appropriate design parameters are used in determining the design loading used for design of the specific installation. Parameters, such as snow loading, wind speed, exposure and topographic factor should be confirmed with the local building official or a licensed professional engineer.

System Fire Ratings

Roof Slope	Module*1	Skirt (Wind Deflector)	Fire Rating*2
Steep Slope ($\geq 2/12$)	Type 1 & 2	—	Class A
Low Slope ($< 2/12$)	Type 1&2	Required	Class A

*1: Module Type per UL 1703 (November 18, 2014).

*2: Class A fire rated PV systems can be installed on Class A, B, and C roofs.

Bonding / Grounding of Modules

This racking system may be used to ground and/or bond a PV module complying with UL 1703 only when the specific module has been evaluated for grounding and/or mounting in compliance with the Roof Tech's UL2703 classification.

Periodic Inspection

Roof Tech Inc. recommends inspecting installed racking system periodically for loose components, loose fasteners and any corrosion. If found, those components are to be re-tightened, or replaced immediately. When a PV module needs to be removed from the PV array for maintenance and/or replacement, the electric bonding system will need to be temporarily restored to maintain the electrical bonding path. Please make sure the system electrical circuits and disconnects are in the open position and the entire system is powered down. Use adequate components that have evaluated to Roof Tech's UL2703 (see page 10) and AGW 8 copper bonding conductor/strap. Cover the fronts of modules in the array with an opaque material to stop the production of electricity. Use appropriate safety equipment such as insulated tools and insulating gloves to protect yourself.

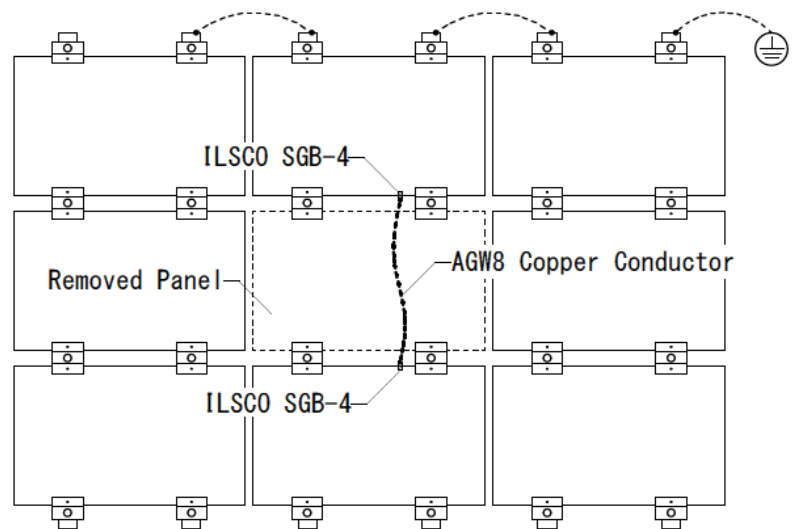

Example of Temporary Bonding Path

Maintenance of the PV modules should be carried out by licensed contractors, according to the PV manufacturer's installation/maintenance instructions and Roof Tech's installation instructions.

Above maintenance should not be conducted under a wet and/or high wind conditions.

Tools & Supplies Required for Assembly

Tools needed for building the array

- Hex socket drive 8 mm (for the base)
- Hex socket drive 7 mm (for the Screw M4x16 SDST)
- Hex bit socket long 8 mm (for the Clamps and Pillar)
- Phillips head screwdriver bit (for the Tapping Screw M4x16)
- Drill and ϕ 3 mm Drill Bit or Center punch for sheet metal
(for Installation on Metal Roof)
- Measuring tape
- Chalk line
- Torque wrench
- Scissors

Torque Values for Dry Bolts: 16 N·m applied to Middle and End Clamps. (in-lbs)

Item	Torque
Hexagon socket head cap screw M10 x50 (Clamp)	16 N·m (142)
	18 N·m (159)
	See APPENDIX Module List
Hexagon socket head cap screw M8x9	12 N·m (106)
Screw 4.0x16 SDST	Fully seat
Tapping Screw 4.0x16	Fully seat
Wood Screw 5.0x60	Fully seat*
**Ilsco Lug SGB-4	3.96 N·m (35)
**Weeb-Lug 6.7	Gr 9.5 N·m (84) - N&B 13.55 N·m (120)

*Proper torque values for a wood screw will vary depending on the rafter and/or deck characteristics; hardness, age, and moisture of the wood. Tighten until the washer just stop rotating easily. (see page 25.). ** Hardware provided by Mfc.

Technical Note:

Avoid the use of an impact driver as it can over torque the hardware.

Please follow manual instruction torque values.

The RT-APEX can be installed on low slope roofs (Metal, EPDM, TPO, SBS Modified Bitumen/Torch-on, Asphalt) and steep slope roofs (Asphalt shingles, Metal). For low slope roofs, make sure there is positive drainage.

RT-Butyl is also compatible with Felt and Synthetic underlayments.

Moisture Content

RT Butyl Flexible Flashing is to be installed on dry mounting surfaces.

Determining how wet is too wet:

First, remove the paper backing from an RT product exposing the clean RT Butyl.

Second, press the base, RT Butyl side down against the surface.

Third, pick up the base. If the base adheres to the roof, the roof is suitably dry for installation.

For Metal, EPDM and TPO remove water from the installation area with a cloth or squeegee before placing and affixing the base. A heat gun, Sodium Chloride or alcohol is suitable to remove ice from the roof surface.

Installation Safety

The installation process requires working on sloped and elevated building surfaces, in outdoor weather conditions, using tools and heavy components designed for the generation of electricity.

- Use properly anchored fall protection equipment.
- Use caution to prevent objects from falling or dropping off the roof area.
- Cordon off ground areas directly beneath the roof work area when possible.
- Always use personal protection equipment such as safety glasses, gloves, etc.
- Do not perform installation in excessively wet, windy, or inclement weather conditions.
- When working in hot weather, work crews should take care to prevent symptoms of over-heating or dehydration.
- Use proper lifting and carrying techniques when handling heavy components at the job site. If conditions are challenging for moving PV modules to the roof area, use a mechanical lift.
- Follow best practices when working around high-voltage electrical equipment.
- Do not anchor fall protection equipment to roof mounts, or any other inappropriate roof structure.

Distance from roof to bottom of PV module

In case of 46mm
PV module height

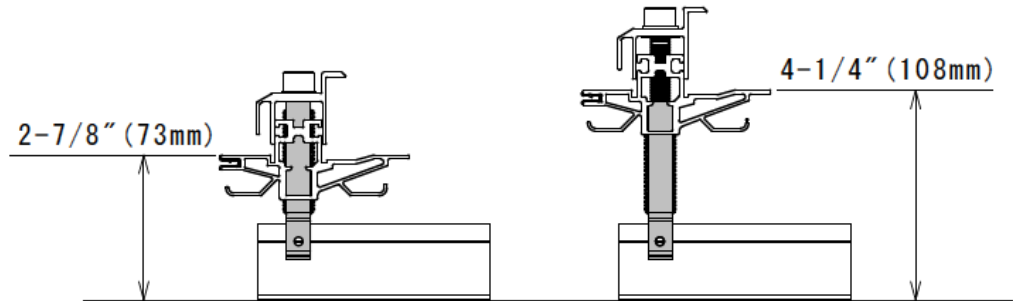

In case of 30mm
PV module height

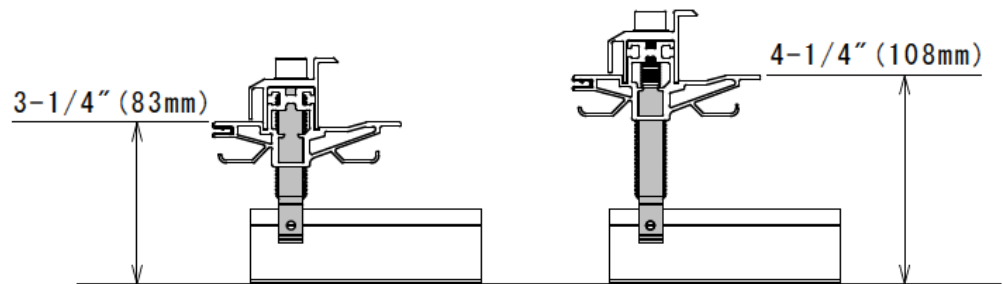

PART A: Materials

1. Items with RT-APEX

① RT-APEX Base

	Item
1A	Base Bracket
1B	Screw 5.0×60
1C	RT butyl

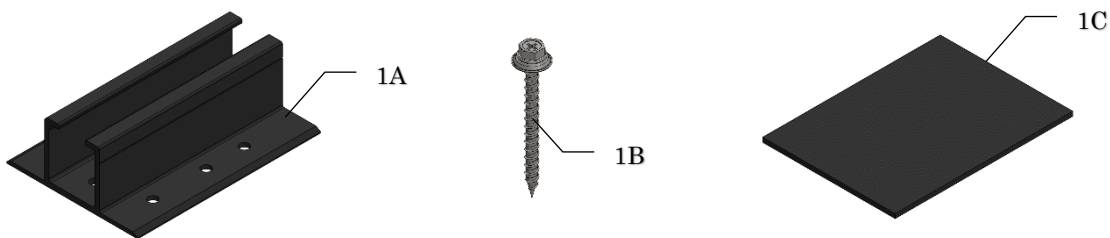

② RT-APEX Middle

	Item
2A	Middle Clamp
2B	U-D Bracket
2C	Pillar Bracket
2D	Hexagon socket set screw M16×55
2E	Hexagon socket head cap screw M10×50
2F	Hexagon socket head cap screw M8×9

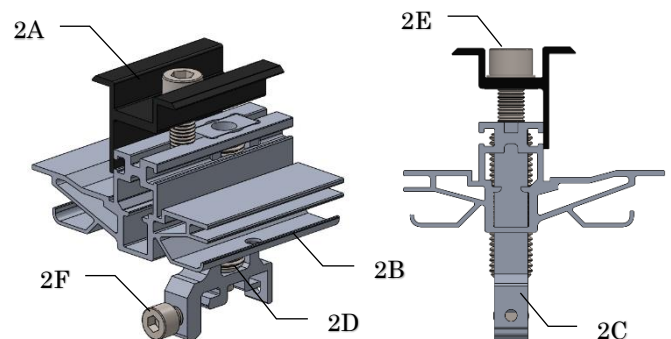

③ RT-APEX Middle Splice

	Item
3A	Middle Splice
3B	U-D Splice
3C	Pillar Bracket
3D	Hexagon socket set screw M16×55
3E	Hexagon socket head cap screw M10×50
3F	Hexagon socket head cap screw M8×9

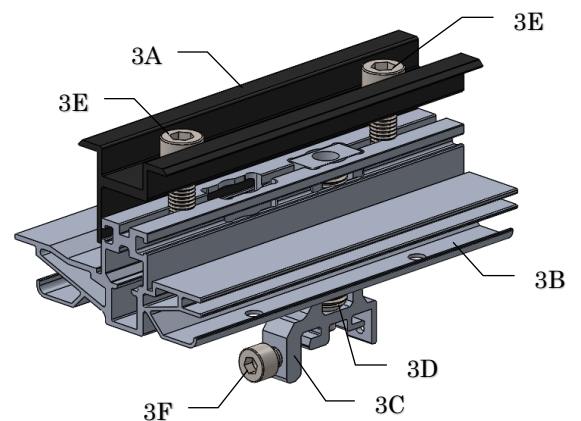

④ RT-APEX End

	Item
4A	End Clamp
4B	U-D Bracket
4C	Pillar Bracket
4D	Hexagon socket set screw M16×55
4E	Hexagon socket head cap screw M10x50
4F	Hexagon socket head cap screw M8x9
4G	U-D Bonding Clip

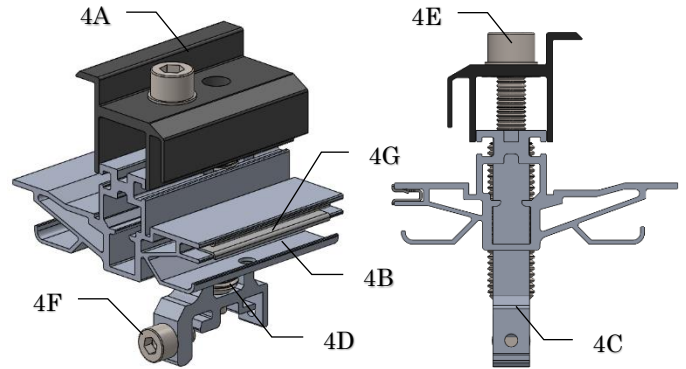

⑤ RT-APEX End Splice

	Item
5A	End Splice
5B	U-D Splice
5C	Pillar Bracket
5D	Hexagon socket set screw M16×55
5E	Hexagon socket head cap screw M10x50
5F	Hexagon socket head cap screw M8x9
5G	U-D Bonding Clip

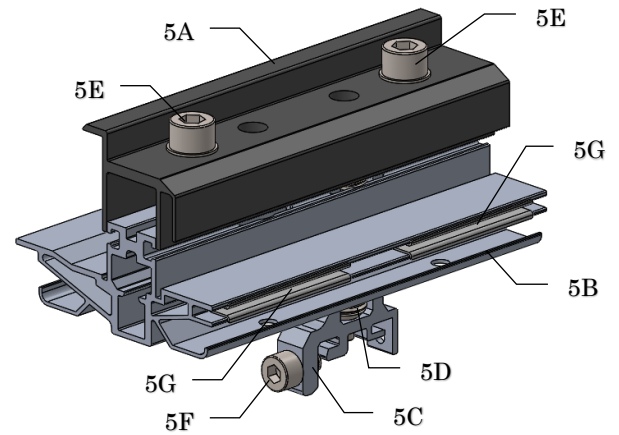

⑥ RT-APEX Floating Splice (Middle & End)

	Item
6A	Middle Splice
6B	End Floating Splice
6C	U-D F-Splice
6D	Hexagon socket head cap screw M10x50
6E	U-D Bonding Clip

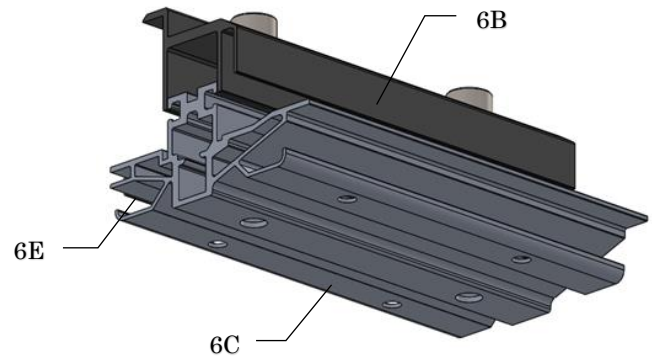
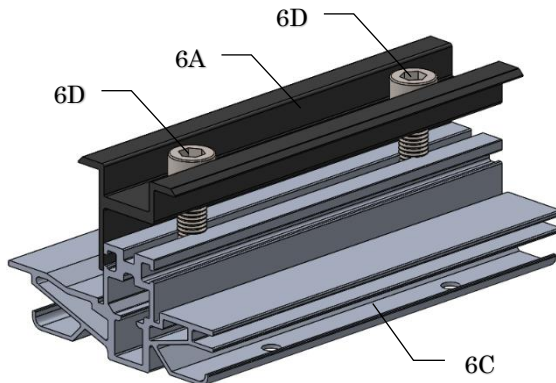
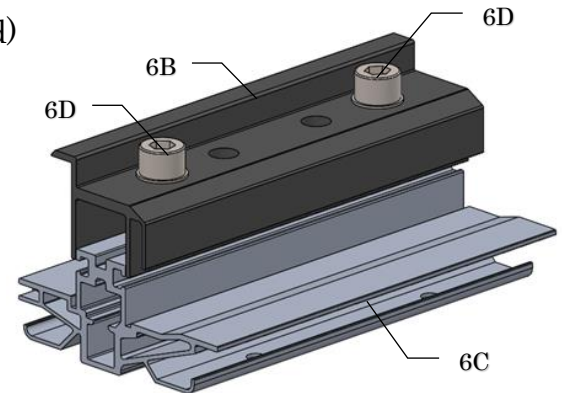

⑦ RT-APEX Skirt 80

	Item
7A	Eaves Cover L-2032

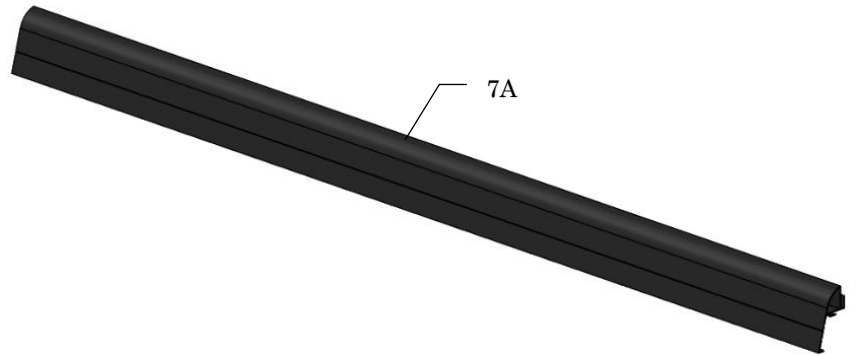

⑧ RT-APEX Skirt Bonding Splice (Optional)

	Item
8A	Eaves Cover Joint

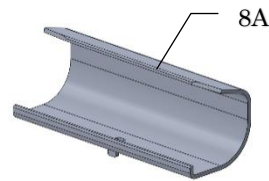

⑨ RT-APEX Skirt End Cap (Optional)

	Item
9A	End Cap (Left)
9B	End Cap (Right)
9C	Tapping Screw M4x16

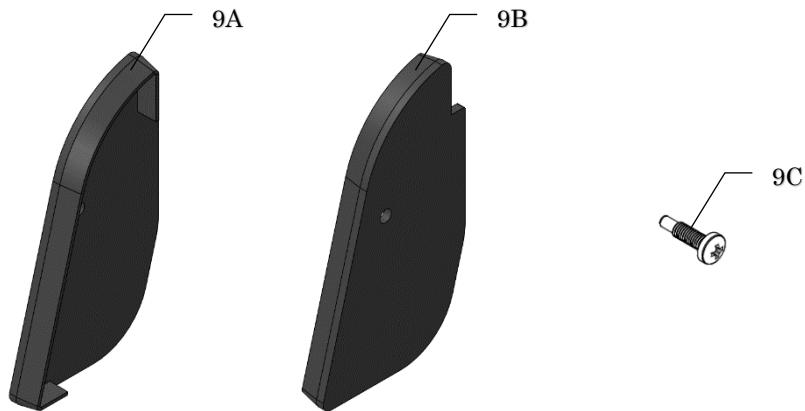

⑩ RT-APEX Screw (Optional)

	Item
10A	Screw M4x16 SDST

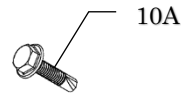

⑪ RT-APEX SUMO Clip (Optional)

	Item
11A	SUMO Clip

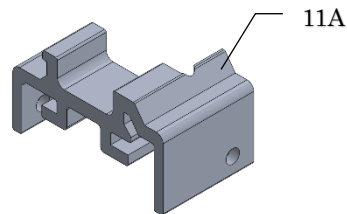

⑫ Roof sealant

	Item
12A	Roof sealant

※Recommended Product

- Henry : 208R, 209, 925 (Black)
- Geocel:S2, S4 (Black)
- Sashco : Through the Roof
- Boss : 125 (Black)
- Top Industrial: Rain Buster 850, 900
- Chem Link: M1
- NPC Solar Seal 900
- GE All Purpose 100% Silicone

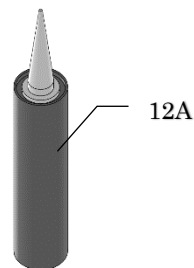

The Sealant adds a layer of UV protection to the Flexible Flashing

2. Module Clamp Table

Clamp	Panel Frame Height	Item ID	Description
Middle Clamp	30 – 46 mm	RT3-02-UM-30-00	RT-APEX Middle
Middle Splice	30 – 46 mm	RT3-02-UMS-30-00	RT-APEX Middle Splice
Middle F-Splice	30 – 46 mm	RT3-02-UMFS-30-00	RT-APEX Middle F-Splice
End Clamp	30 – 46 mm	RT3-01-UE-30-00	RT-APEX End
End Splice	30 – 46 mm	RT3-01-UES-30-00	RT-APEX End Splice
End F-Splice	30 – 46 mm	RT3-01-UEFS-30-00	RT-APEX End F-Splice

3. Grounding···Lugs & Straps

All electrical installation and procedures should be conducted by skilled, licensed and bonded electricians. All work must comply with all national, state and local installation procedures, product and safety standards. These standards include but are not limited to applicable National Electrical Code NEC 690 and NEC 250, National Electrical Installation Standards (NEIS™), UL Standards, and OSHA Regulations.

Note: **Maximum Series Fuse Rating of 30 A. (DynoBond option 20 A)**
Grounding Lugs, Bonding Lugs and Straps are not provided by Roof Tech Inc.

1) BURNDY

• WEEB LUG

①	WEEB-LUG-6.7
②	WEEB-LUG-6.7AS
③	WEEB-LUG-8.0
④	WEEB-LUG-8.0AS
⑤	WEEB-LUG-8.2MS
⑥	WEEB-LUG-15.8

• WEEB-BONDING JUMPER

①	WEEB-BNDJMP6.7
②	WEEB-BNDJMP6.7AS
③	WEEB-BNDJMP8.0
④	WEEB-BNDJMP8.0AS
⑤	WEEB-BNDJMP8.2MS
⑥	WEEB-BNDJMP9
⑦	WEEB-BNDJMP12
⑧	WEEB-BNDJMP24
⑨	WEEB-BNDJMP36

2) ILSCO

• ILSCO Dual Rated Lay-In Ground Lug type SGB

①	SGB-4
• ILSCO Dual Rated Lay-In Ground Lug type GBL	
①	GBL-4
②	GBL-4SS

• ILSCO Copper Lay-In Ground Lug Direct Burial type GBL-DB

①	GBL-4DB
②	GBL-4DB-14
③	GBL-4DBT
④	GBL-4DBT-14

Alternative ground lugs that are UL 2703 listed can also be utilized.

PART B: Landscape Layout

1. Installation of Brackets

(1) Brackets Layout

a) Installation on the **RAFTER**

Example (Scale: Not to Scale)

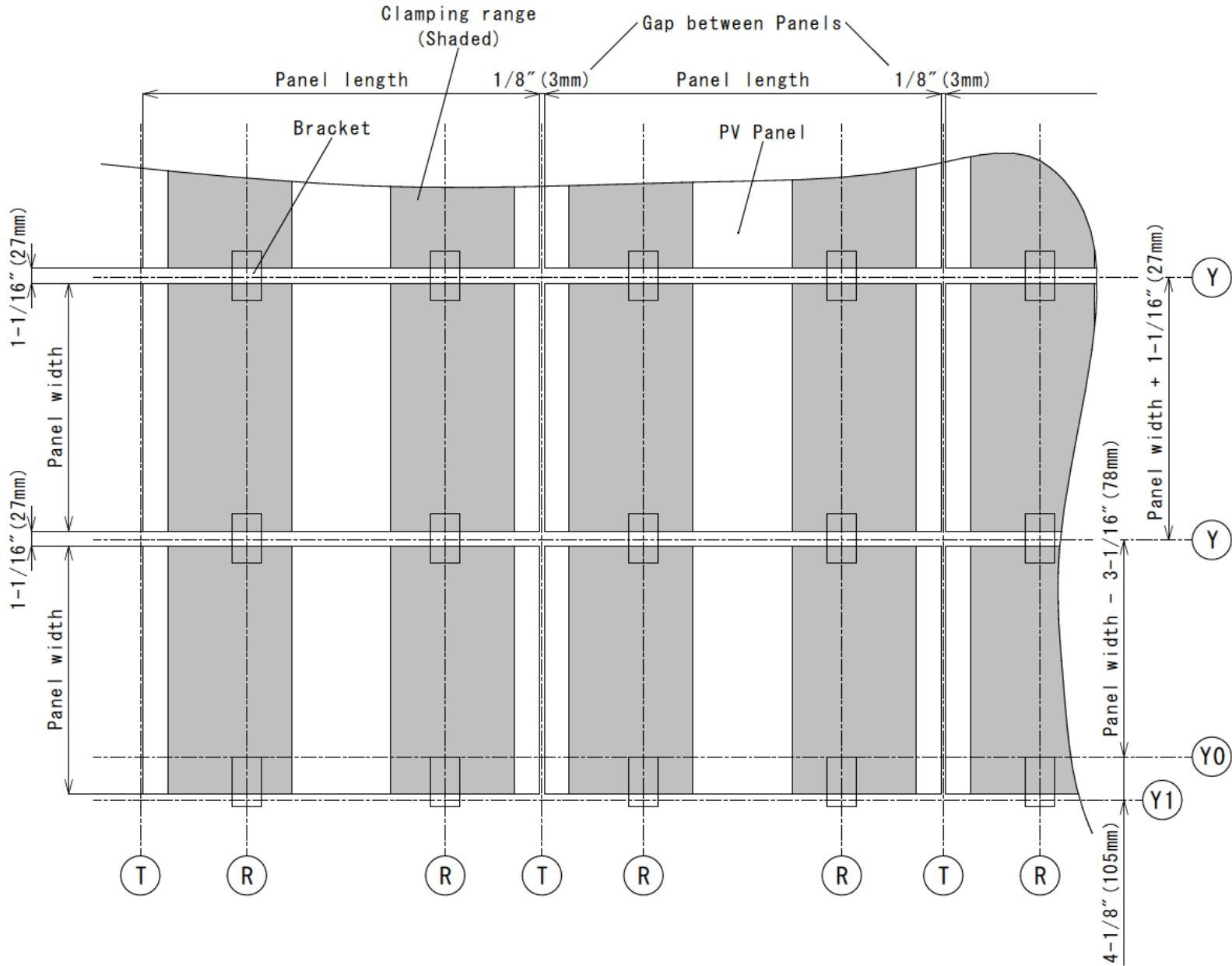

Note: Minimum distance $1/8''$ (3 mm) between panels.

LANDSCAPE BRACKET LAYOUT

① Chalk line according to the layout plans to indicate bracket's position.

(i) Line Y0: Position the lower base upper edge at $\frac{3}{16}$ " (5 mm) from the edge of the upper composite shingle.
(see illustration bellow)

(ii) Line Y1: Delineates the location of the Pillar Bracket's eaves side for the first row at $4\text{-}\frac{1}{8}$ " (105mm) from Line Y0 (upper edge of base bracket).

(iii) Line Y: Center of brackets of the second and subsequent rows. The distance between Y1-Y and Y-Y shall be the width of panel (refer to Pg. 11 illustration) plus $1\text{-}\frac{1}{16}$ " (27mm, equivalent to the width of a Panel Spacer and middle clamp).

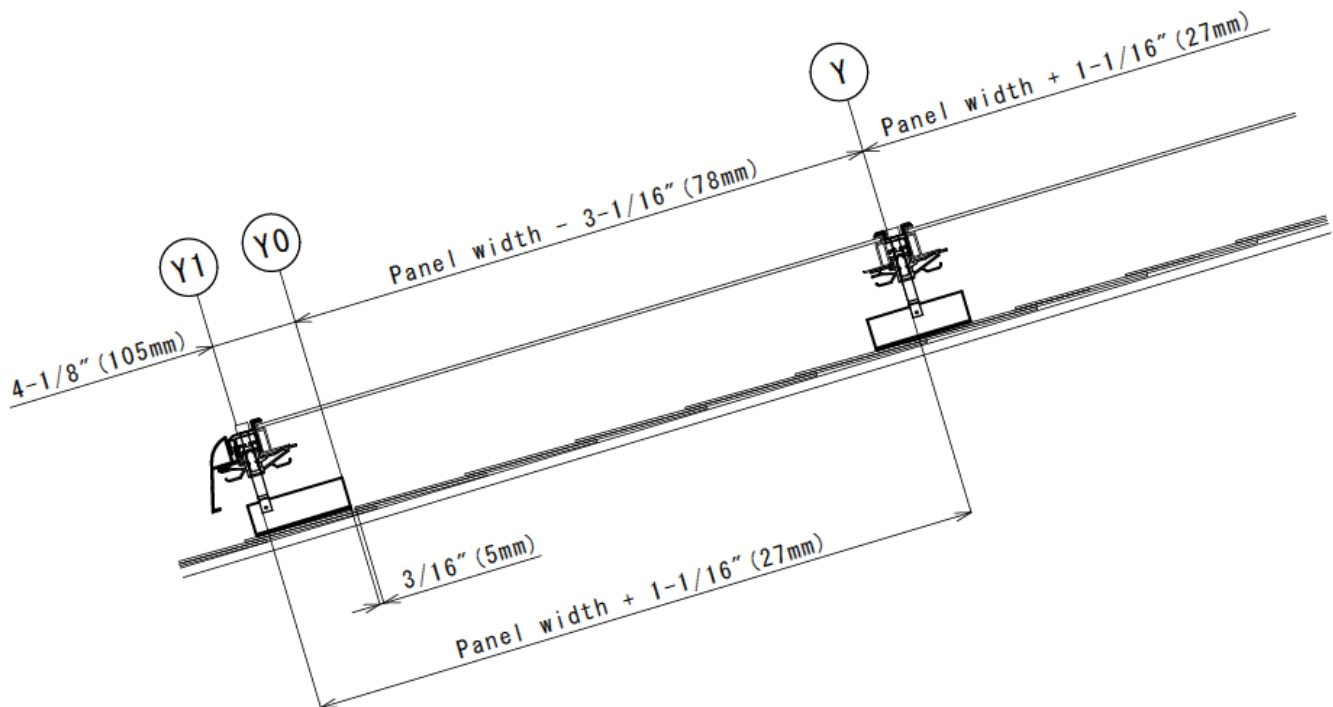
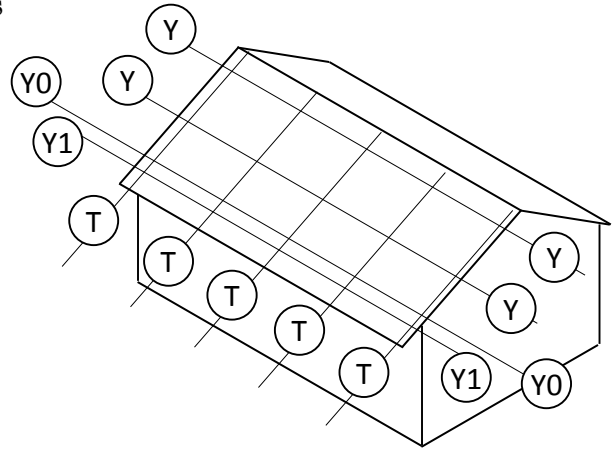

(iv) Line T: It delineates the center line of the spacing between adjacent rows. The distance between T Lines shall be the length of a panel (see illustration from Pg.11) plus the spacing between rows. We recommend a minimum of $\frac{1}{8}$ " (3 mm) spacing between adjacent rows to allow for thermal contraction and expansion.

- ② Aligning the brackets. Choose the most suitable rafter for the array, then draw chalk lines to mark their center.

(i) Line R: Rafter center line.

The Engineer of Record (EOR) shall verify the framing capacity and fastener installation for building code compliance including those of the National Design Specification for Wood Construction (NDS 2005/2012/2015) as applicable.

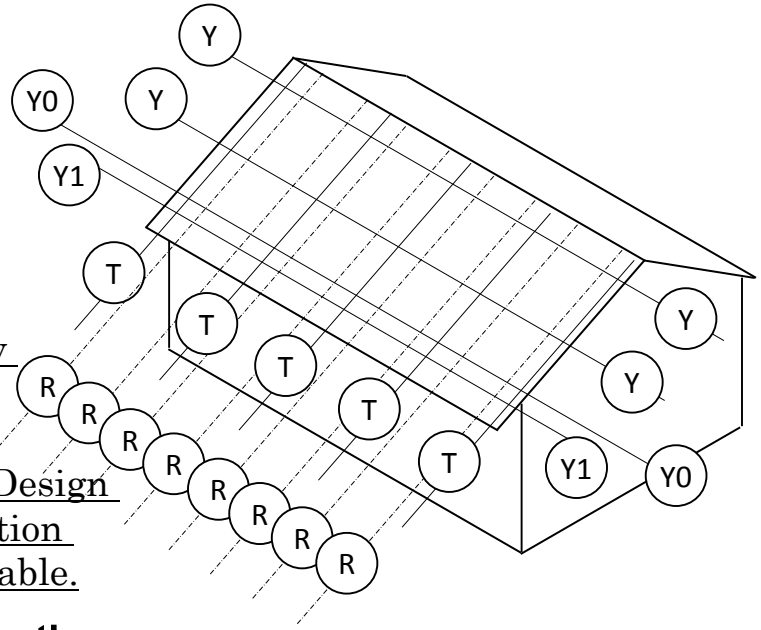

! Attention

According to the NDS, the distance from the side edge of the rafter and the 5 mm diameter mounting screws for RT-APEX shall be more than 5/16" (7.9 mm).

Note: Minimum Edge Distance = 1.5D
Where D is the Diameter of the screw.
Direction of Loading: Parallel to Grain
(See NDS 2015 Table 12.5.1c.)

The mounting screw shall hit this area.

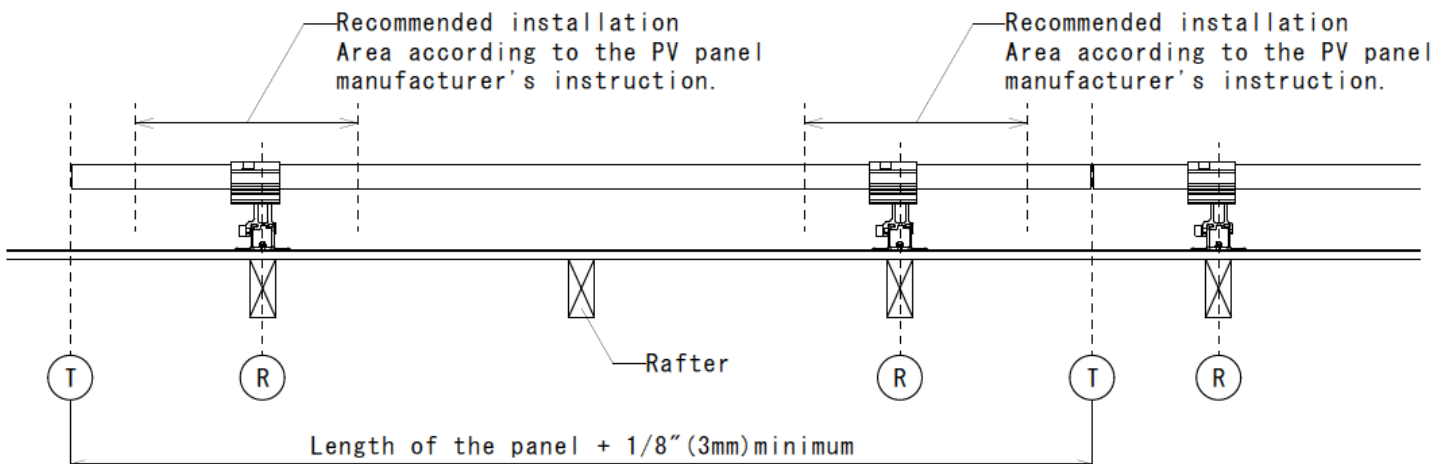
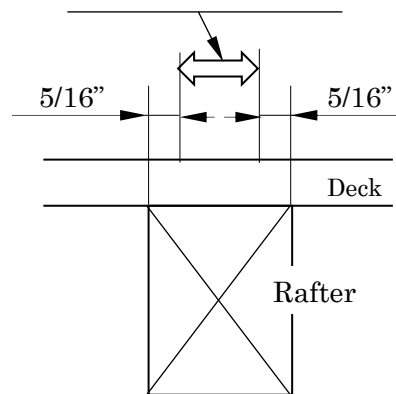

b) Installation on the **DECK**

Example (Scale: Not to Scale)

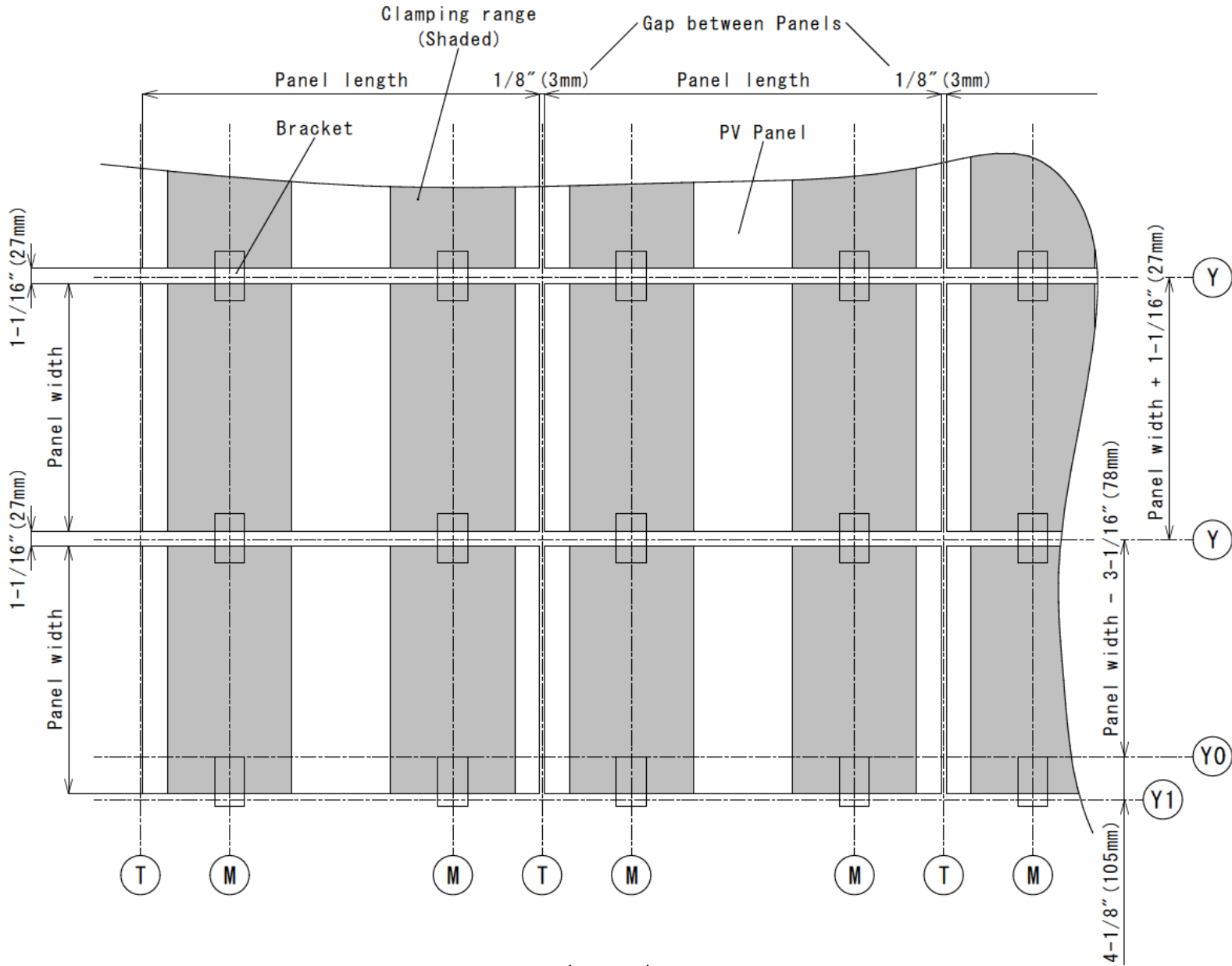

Note: Minimum distance $1/8"$ (3 mm) between panels.

LANDSCAPE BRACKET LAYOUT

① Chalk line according to the layout plans to indicate brackets position.

(i) Line Y0: Position the lower base upper edge at $\frac{3}{16}$ " (5mm) from the edge of the upper composite shingle.
(see illustration bellow)

(ii) Line Y1: Delineates the location of the Pillar Bracket's eaves side for the first row at $4\text{-}\frac{1}{8}$ " (105mm) from Line Y0 (upper edge of base bracket).

(iii) Line Y: Center of brackets of the second and subsequent rows. The distance between Y1-Y and Y-Y shall be the width of panel (refer to Pg. 14 illustration) plus $1\text{-}\frac{1}{16}$ " (27mm, equivalent to the width of a Panel Spacer and middle clamp).

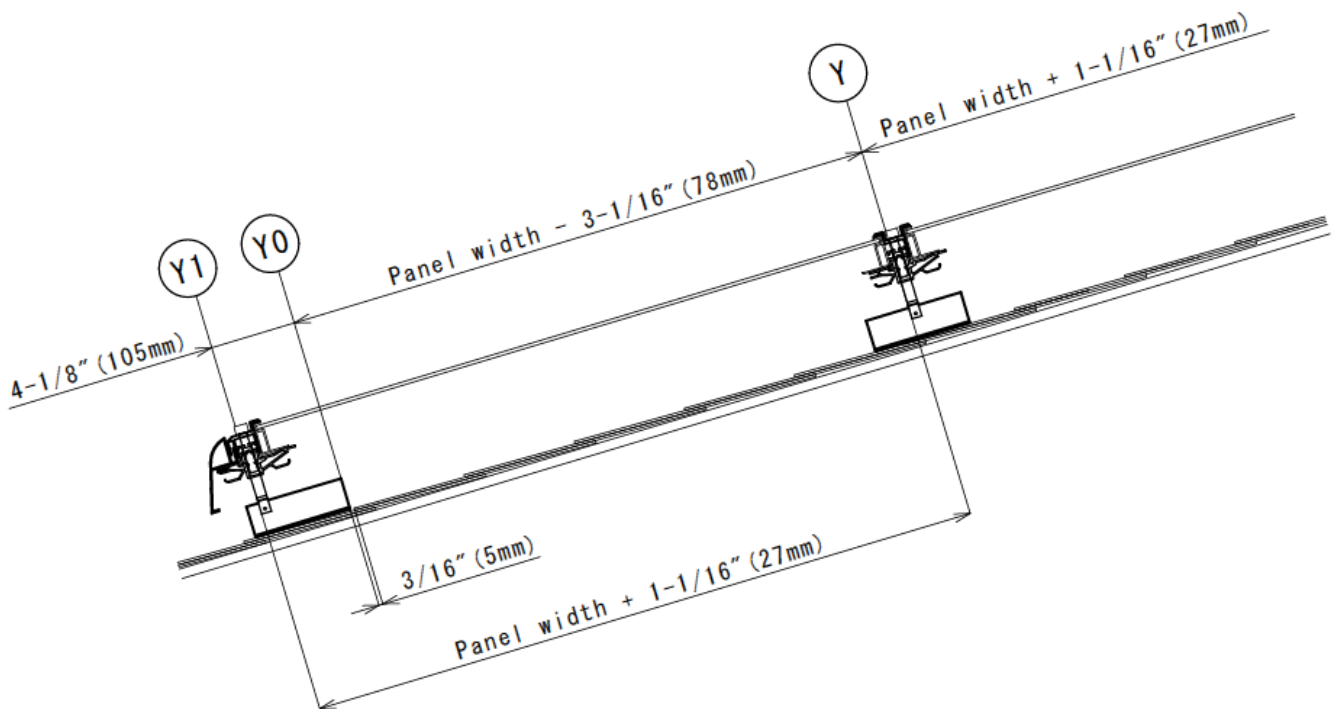
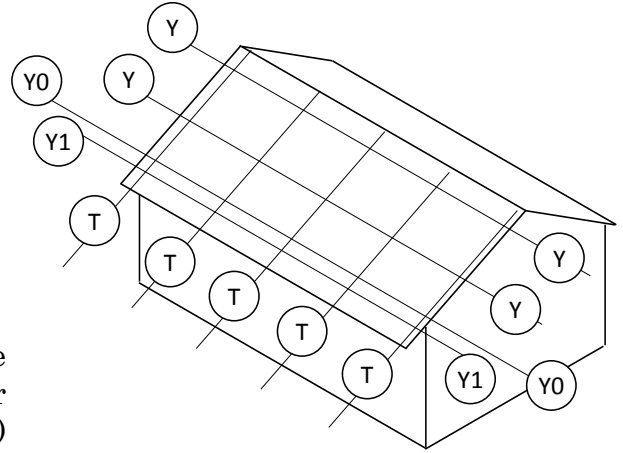

(iv) Line T: It delineates the center line of the spacing between adjacent rows. The distance between T Lines shall be the length of a panel (see illustration from Pg.14) plus the spacing between rows. We recommend a minimum of $\frac{1}{8}$ " (3mm) spacing between adjacent rows to allow for thermal contraction and expansion.

- ② Position the brackets. Select the clamping location (M) according to the PV module installation instructions.

(i) Line M: Bracket center line.

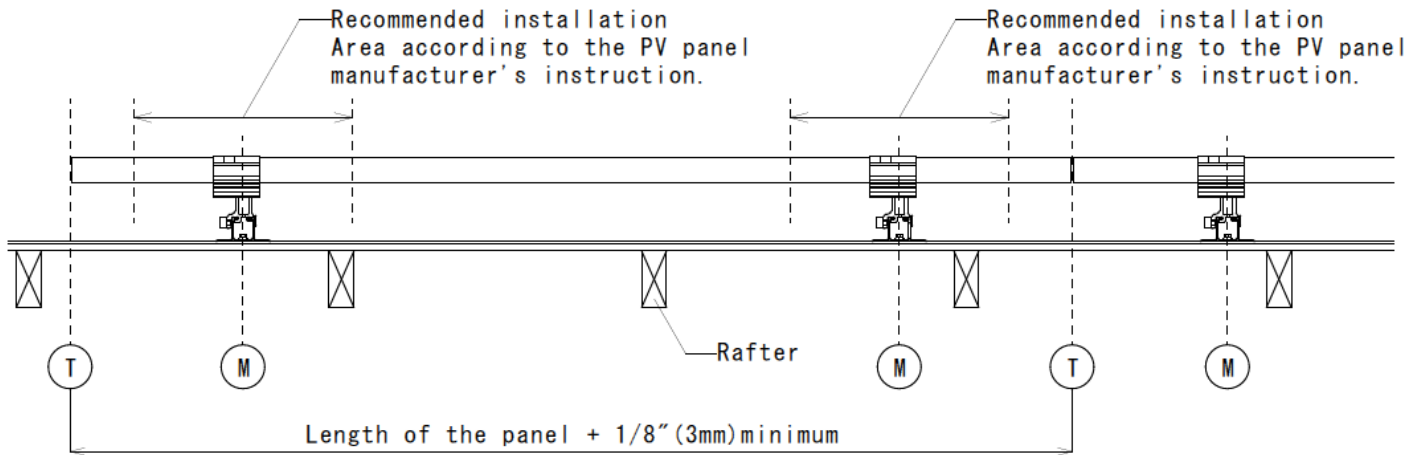
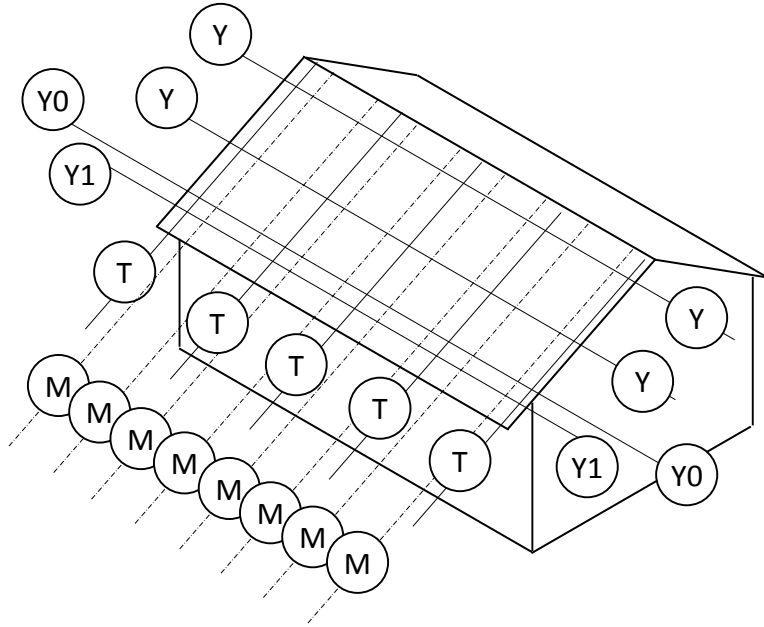

(2) Bracket Installation

! Attention

To maintain the flashing performance, avoid installation when the temperature is below 22F or above 176F.
RT Butyl must be installed on a dry and free from debris surface.

- ① Mark the location at the intersection of the YO or Y Line and R/M Line.
(Top of the first row bracket.)

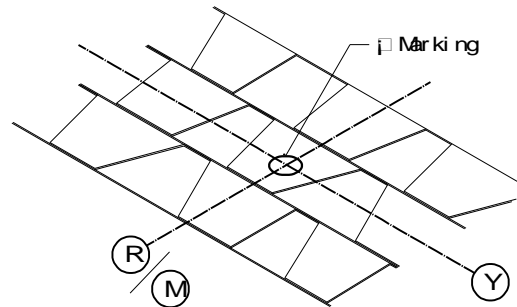
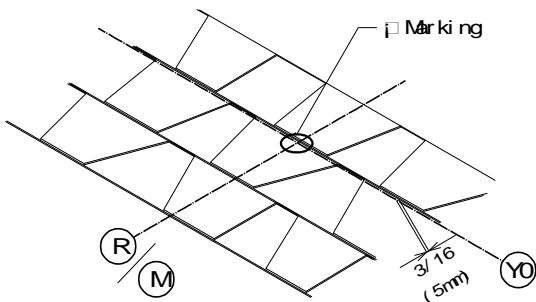
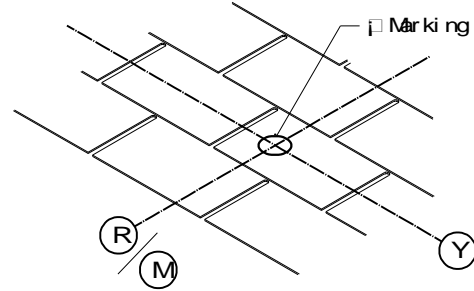
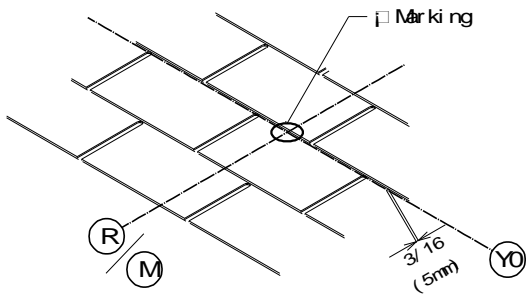

LANDSCAPE BRACKET INSTALLATION

② Choose “A” or “B” installation at each bracket location.

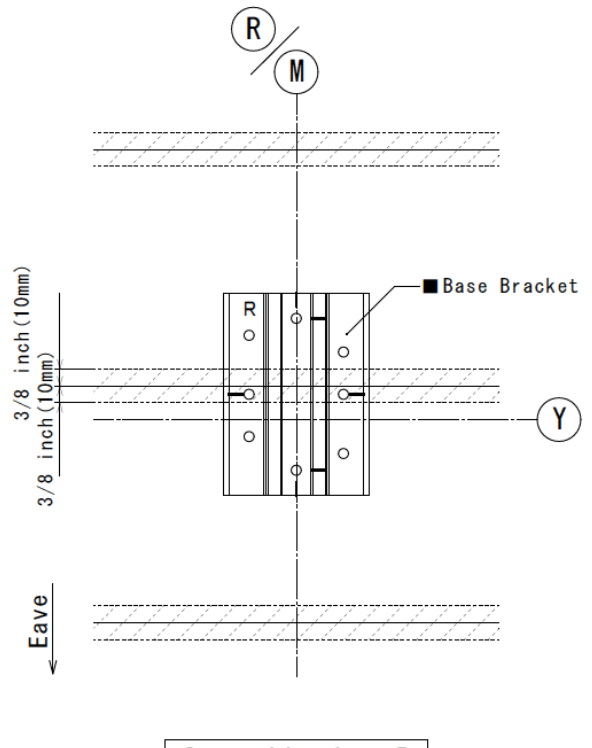
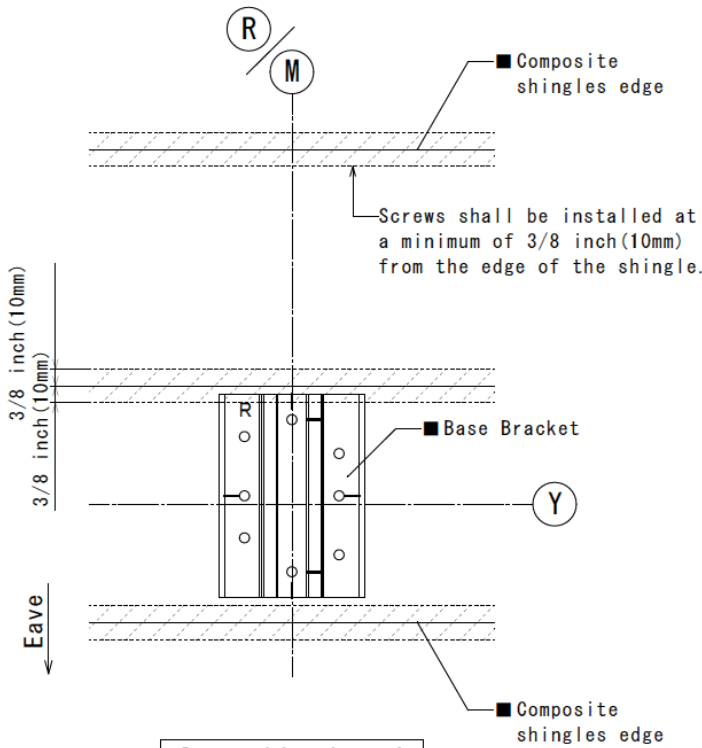
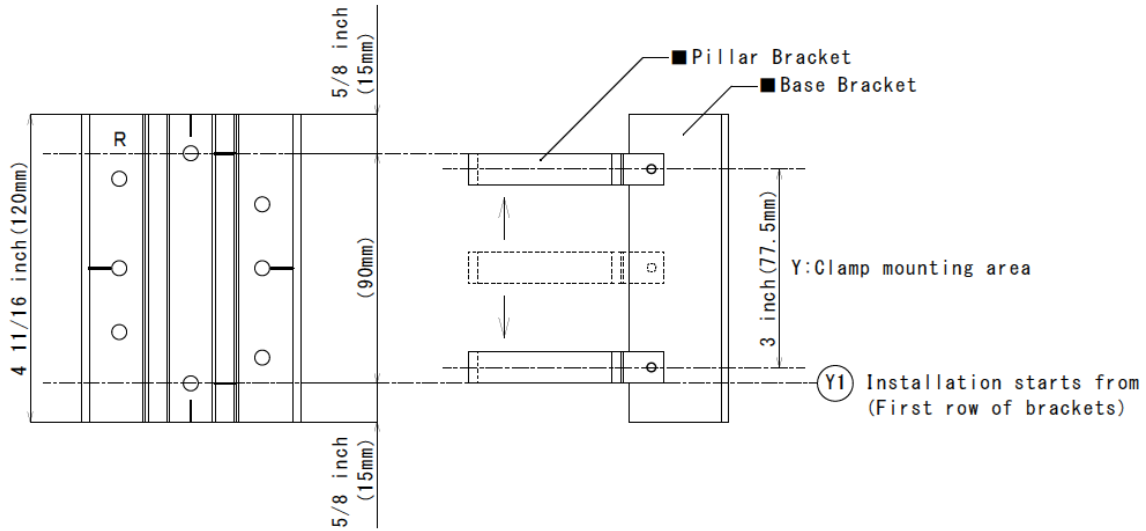

! Attention

Minimum clearance between mounting screws and the edge of the roofing shingle shall be 3/8" (10 mm).

In case the stainless screw hit the nail underneath the shingle;

- 1) Tip the driver at an angle.**
- 2) Use a 3 mm steel drill to make a hole.**
- 3) If possible, remove the nail from underneath.**

- ③ Adjust the RT butyl tape to match the height of the upper shingle. When there is a gap, a slit, or a height difference at the mounting location of the bracket, use additional RT butyl tape (Installation B).

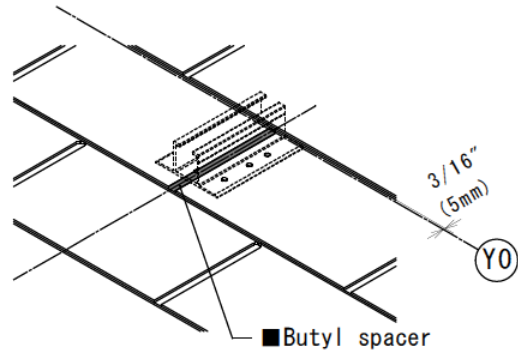

- When there is a slit at the installation spot, fill in with the additional RT butyl tape. The slit must be filled with RT butyl tape.

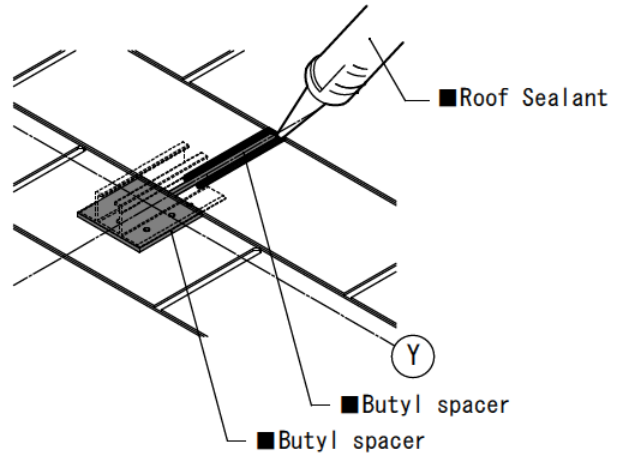

- When there is a slit above the bracket, fill it in with RT butyl tape to match its shape. Apply roof sealant around the RT butyl tape.

Notice that the roof sealant is only used to add a protective layer to the RT butyl tape.

- Best to position the bracket 2" away from the slit.
- If the mounting screw is within less than 2" from the slit, fill the slit with RT butyl tape.

Rafter Install

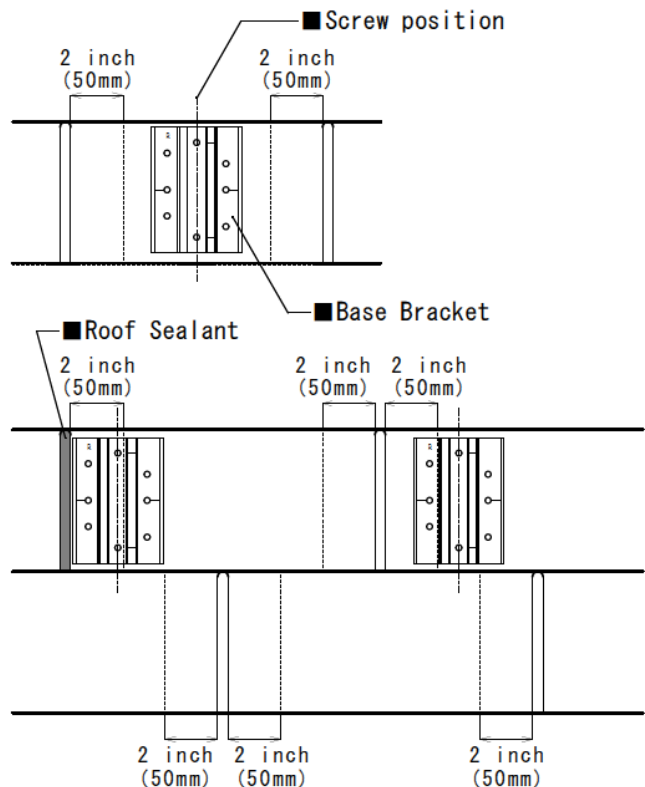

- When there are gaps in the position to install, cut RT butyl tape to the shape and apply it.

Note: Each bracket comes with a RT butyl tape, and is supplied with an additional tape.

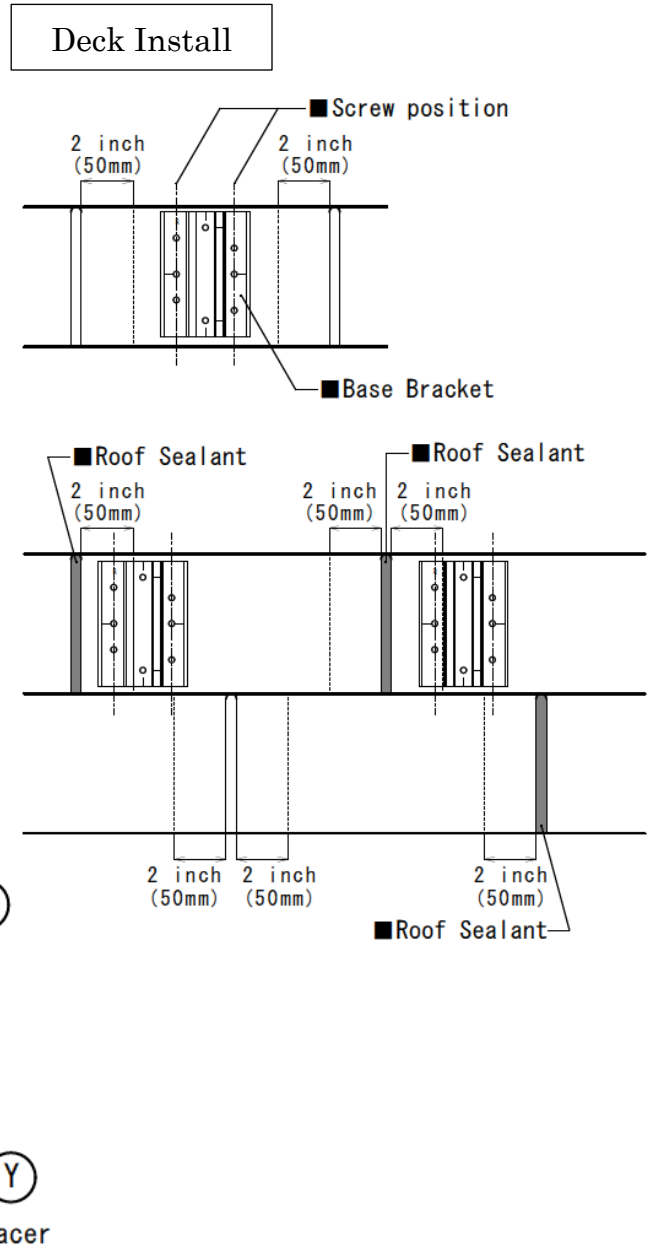

! Attention

Peel off the protection paper from the RT butyl tape. Be sure that the RT Butyl tape covers the entire surface of the bracket.

Base Leveling Options

[Case 1]

- Use RT butyl tape to level the surface of the composite shingle roof.

When there are gaps in the position to install, cut RT butyl tape to the shape and apply it. It is an option to cut the upper (unsealed) layer from an architectural shingle once it is unsealed (loose).

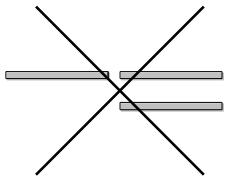
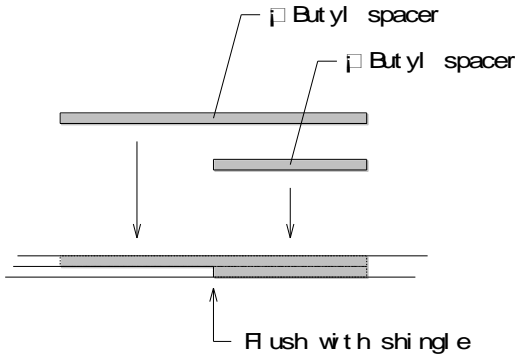

Note: Do not splice the butyl tape.

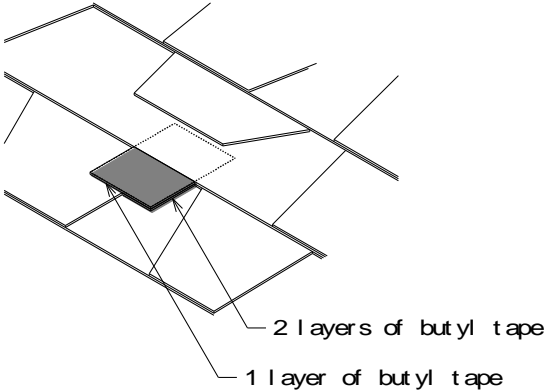
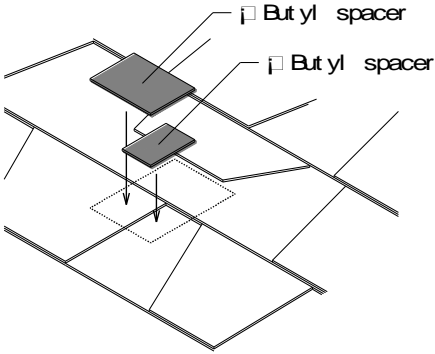
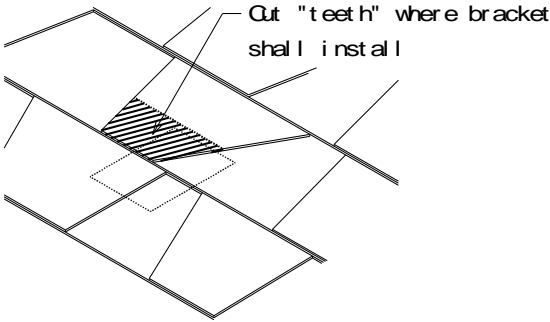

[Case 2]

- Building layers of RT butyl for the bracket to be mounted over the teeth region of composite shingle roofs.

We recommend 4 layers maximum.
Layer 1 is already applied to the bottom of the bracket.

The following layers must be cut to shape to cover the surface of the bracket at each location, assuring a leveled surface.

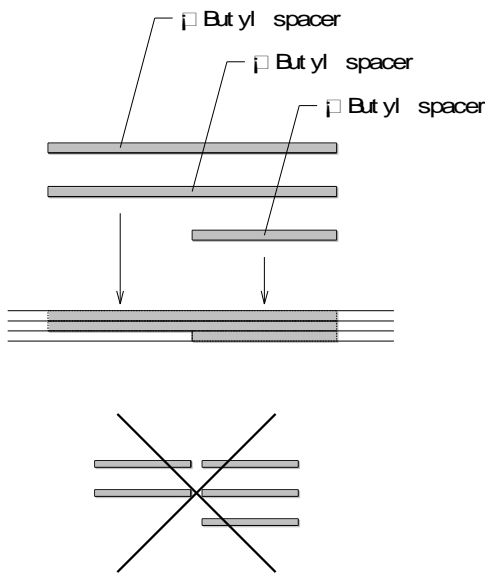

Note: Do not splice the butyl tape.

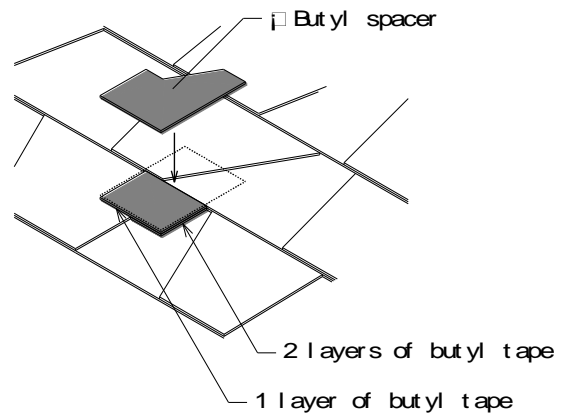
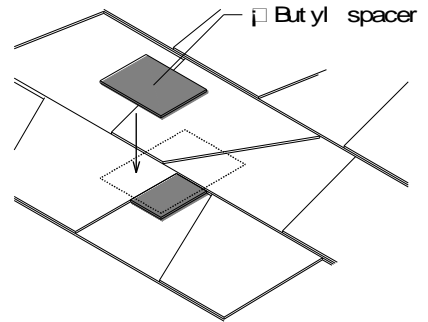
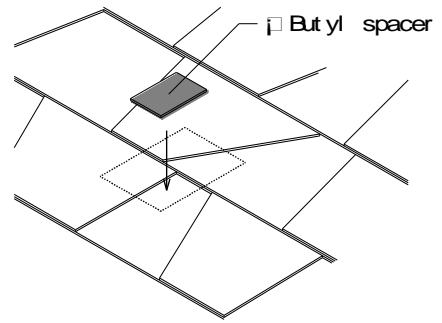

[Case 3]

- Roofing Leveling Option

The application of one layer of asphalt roofing shim with the proper asphalt roofing cement is an alternative to leveling when a Roof Tech base is to be installed between 2 levels (layers of asphalt shingles).

- ④ Starting eave edge installation.
Brackets shall be installed per
installation A (Pg.18).

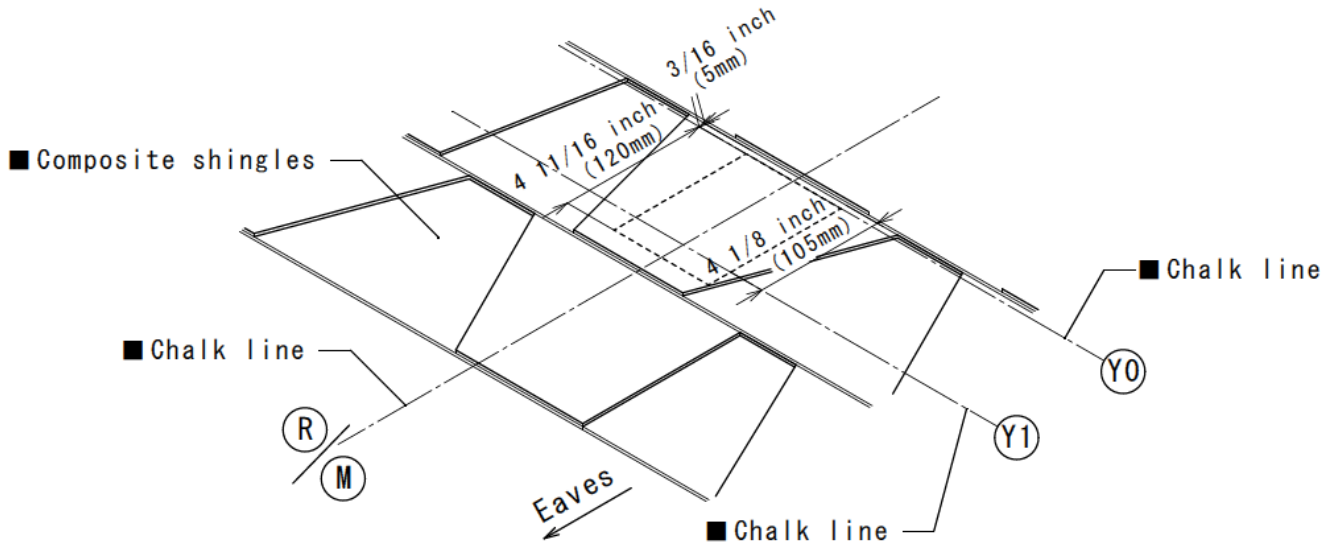

- ⑤ Be sure to inspect RT Butyl tape
covers the entire surface. If not,
use a new mount.

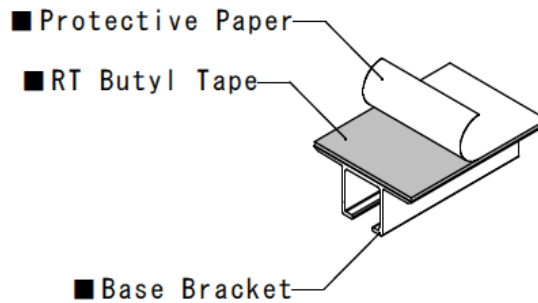

Attention

Do not leave any protective paper on the surface of the RT butyl tape, it can cause an improper seal and may allow water intrusion under the bracket.

⑥ Installing the bracket.

Place the brackets at the specified position with RT butyl tape and make sure the RT butyl attaches well to the roofing surface.

Set the bracket with 2 ea. screws (for RAFTER), or 5 ea. (for Roof DECK), 5.0×60 mm stainless wood screw using 8 mm socket.

After completing process, make sure the brackets are securely fixed.

! Attention

•Note: "R" logo on top right of the base should always be on the ridge side when installing.

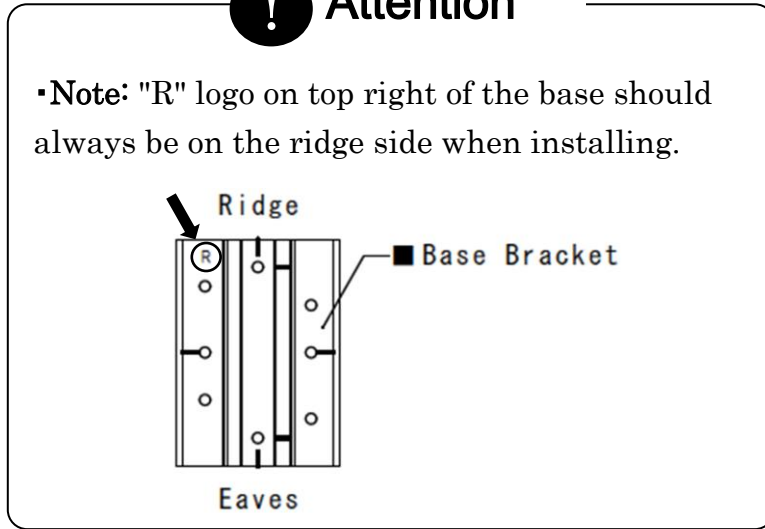

Rafter Install

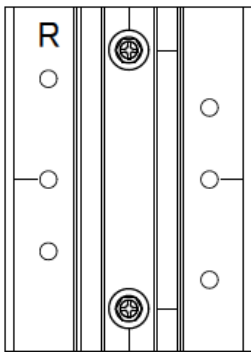

The screw location for Rafter Installation

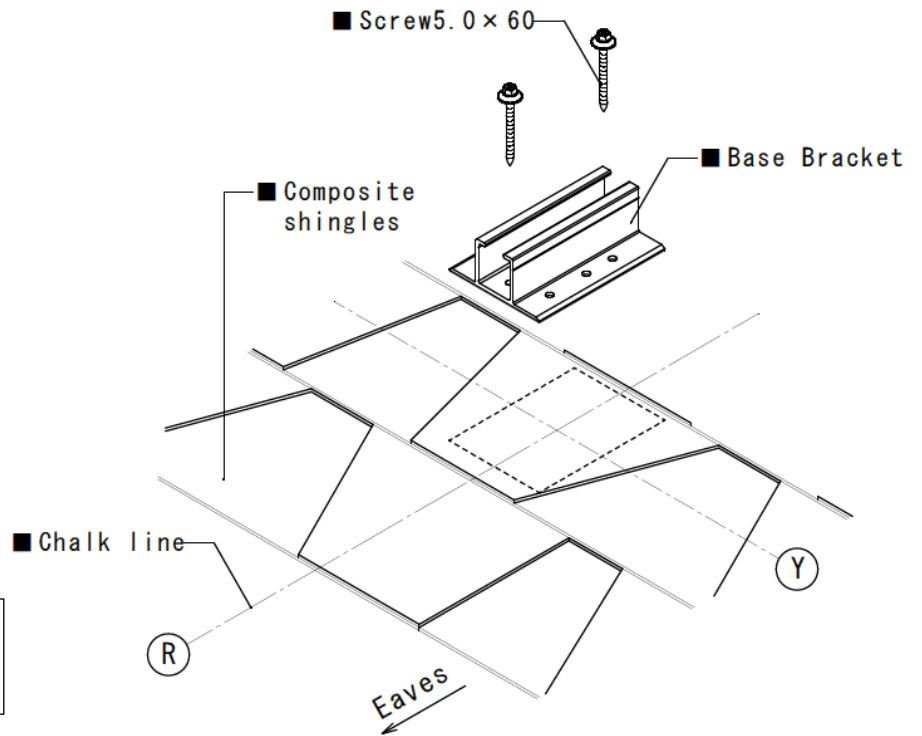

Deck Install

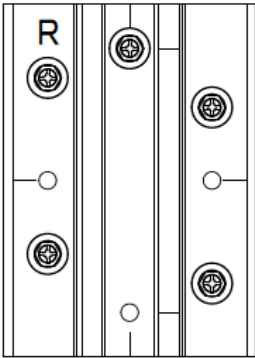

The screw location for Deck Installation

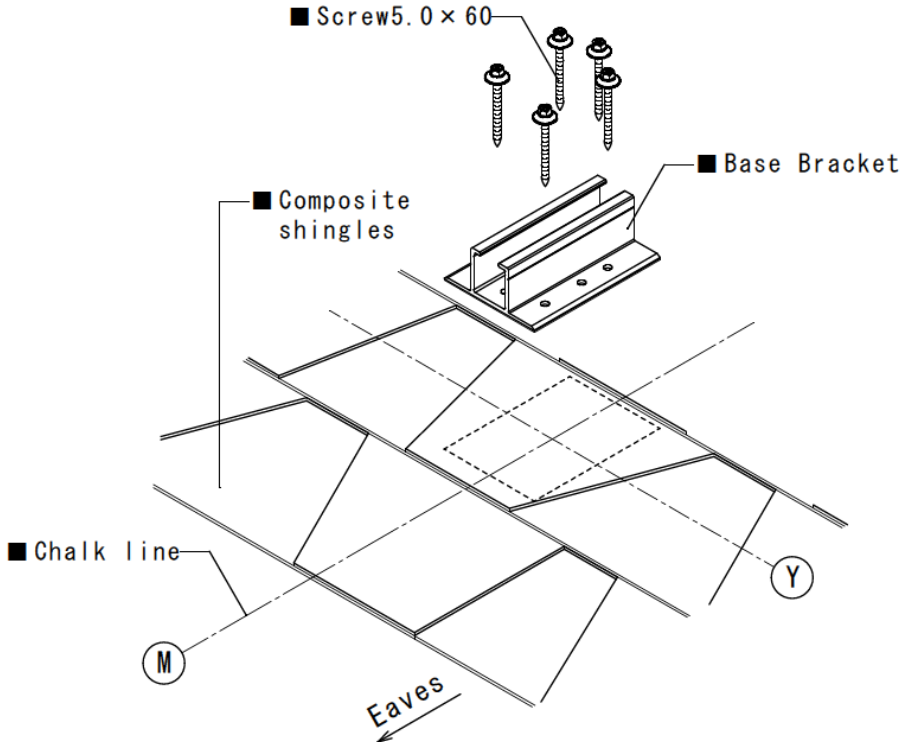

! Attention

Note: Proper torque values for the 5.0x60 mm screw will vary depending on the rafter and/or deck characteristics; hardness, age, and moisture of the wood. Tighten until the washer just stop rotating easily.

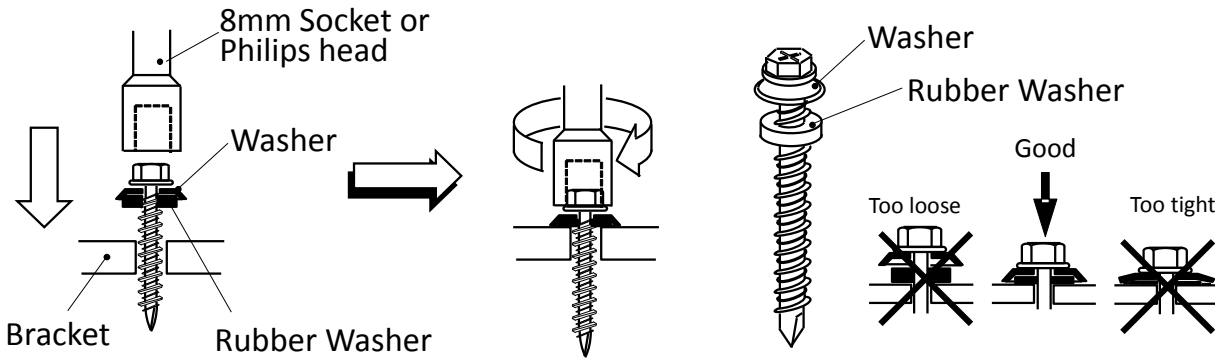

When tightening the screws please tighten all screws equally and avoid using an impact driver as it can over torque the screws or even snap the head off.

- ⑦ [OPTIONAL Sealant Layer] Cover the exposed RT butyl tape with roof sealant. Apply roof sealant around the brackets, the top and each side edge of the brackets. The purpose for the sealant is to add a layer for UV protection.

It is not necessary to seal the bottom of the brackets.

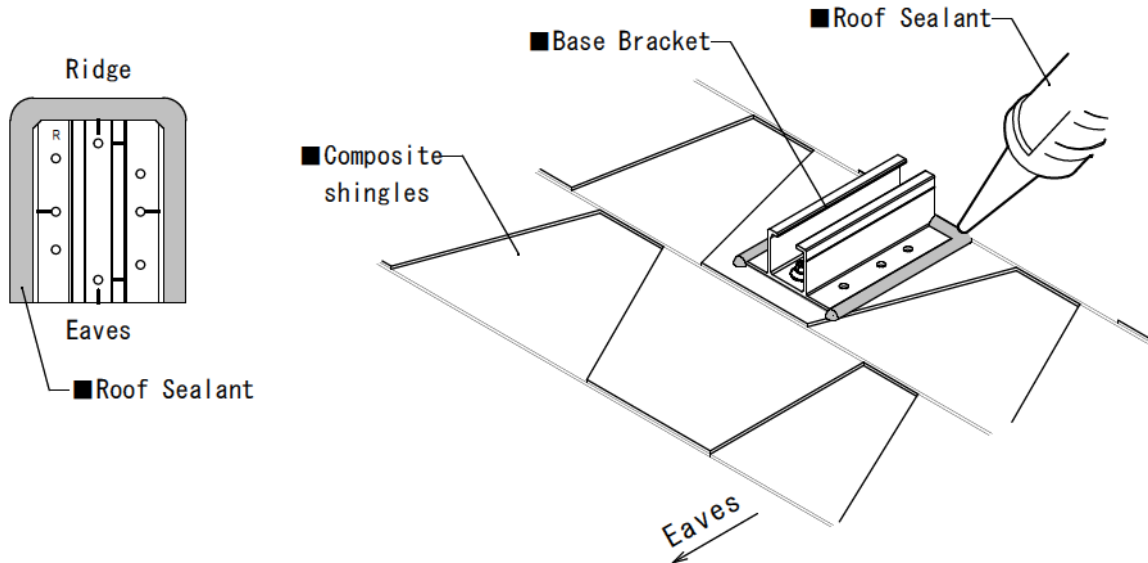

※Optional installation on the Ridge (top row) of the array only!

(See Pg. 33)

This option allows for the end clamp to be installed on the ridge side without removing the top/ridge side clamp only. Rotating the entire set (base and top ridge end clamp) 180 degrees, eliminates the need to remove and rotate the End Clamp from the U-D base.

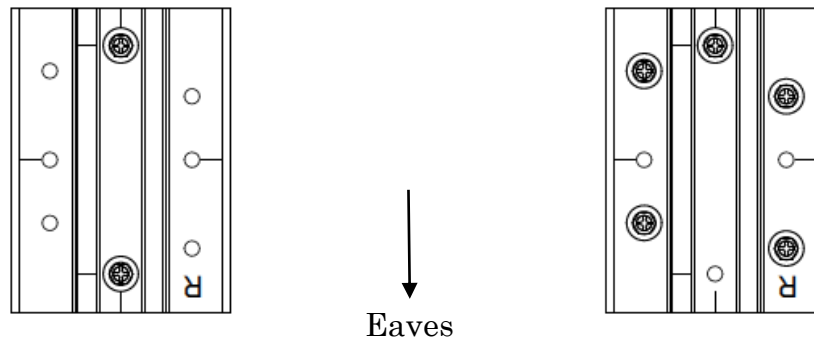

The screw location for
Rafter Installation

The screw location for
Deck Installation

2. Installation of Panels

(1) Aligning and Leveling the Brackets

- ① Slide in the end & middle clamps to the RT-APEX base.

Note : Once the eaves clamp is installed add the ridge clamp so module can be dropped in place.

! Attention

Be aware of the sharp tip of bonding pin at underside of the clamp flange.

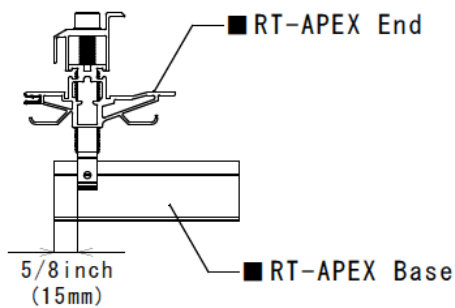
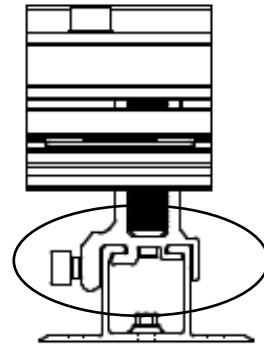
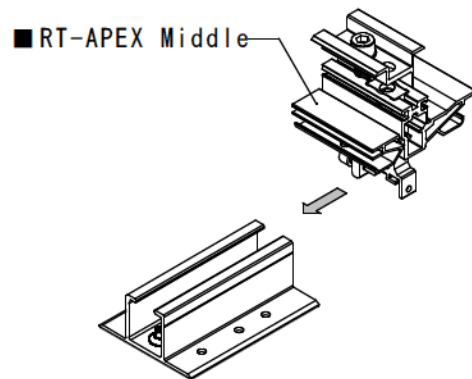
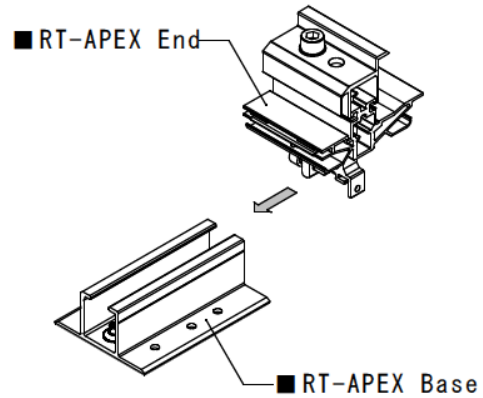

For the first and last rows

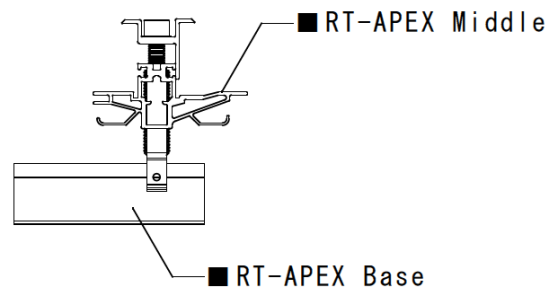

For the middle rows

- ② Stretch a string line tight along the Y1 line between the first and last brackets in the first row.

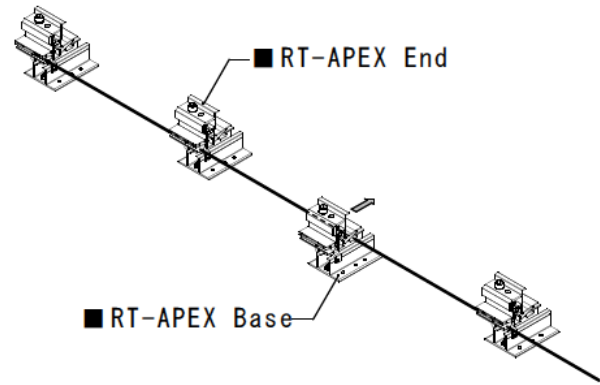

- ③ Align all the Pillars on the row, using the string line as a guide.

Align the Pillars on the eaves side

- ④ Tighten Head cap M8x9, on bottom side of Pillar to 106 in-lbs (12 N·m) torque.

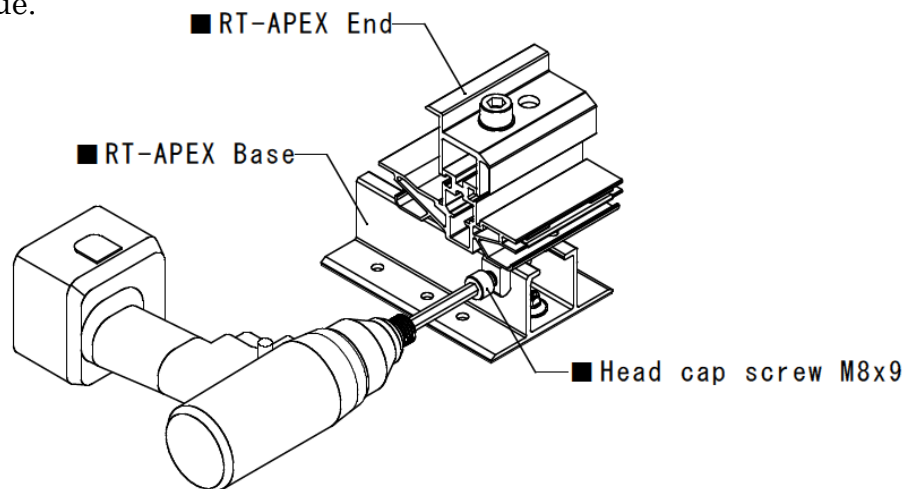

Attention

Maximum Torque value for the head cap M8x9 is 106 in-lbs (12 N·m).

- ⑤ Adjust the height of all the brackets using a hex bit socket (8 mm).

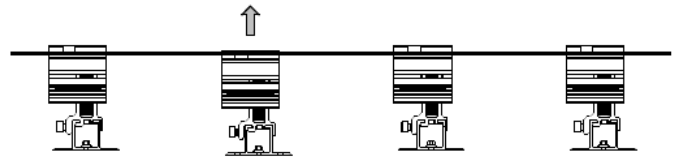

Level the bracket height

- ⑥ Adjusting height shall be done within the range from bottom where the Pillar hits the clamp, to the top where the pillar is flush to the top of U-D bracket. Adjustable height is up to 1" (30mm frame), 1 3/8" (46mm frame).

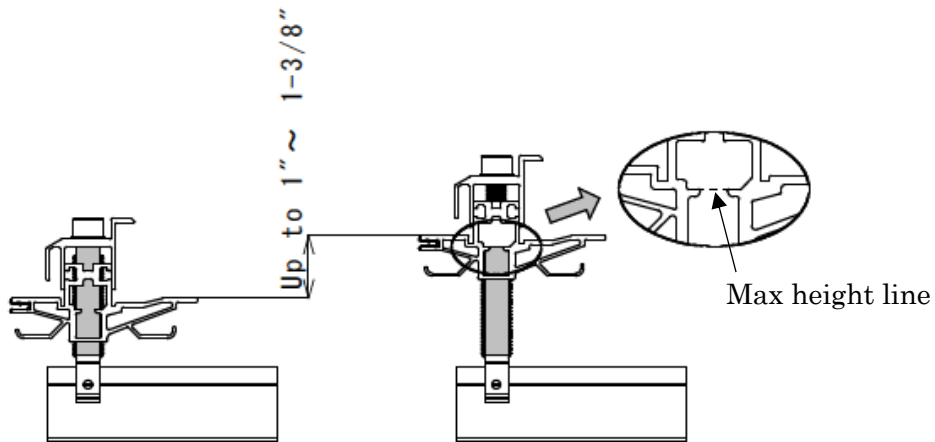
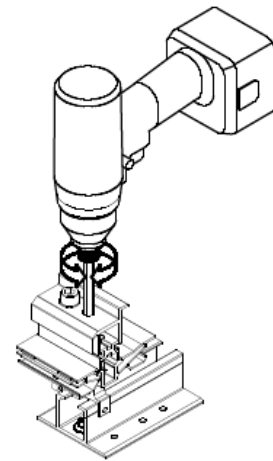

If you are installing the Eaves Cover (Skirt) for RT-APEX,
Skip to "3. Eaves Cover : Skirt (Optional)" on page 36.

(2) End Clamp and the First Row Panel Installation

- ① Place the PV panel on the U-D bracket.

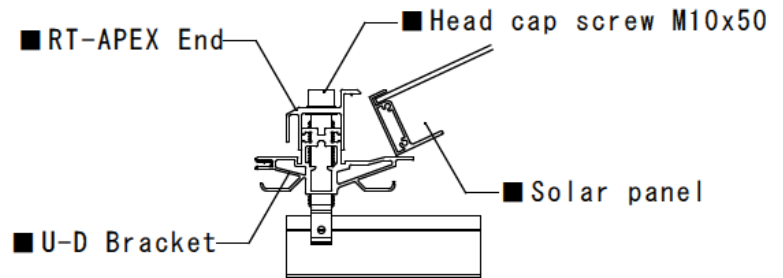

- ② Make any adjustment then tighten the end clamp head cap screw M10 to 142 in-lbs (16 N·m) or 159 in-lbs (18N·m) torque (see UL 2703 appendix for the proper torque value).

- ③ Repeat ① and ② for all the first row panels.

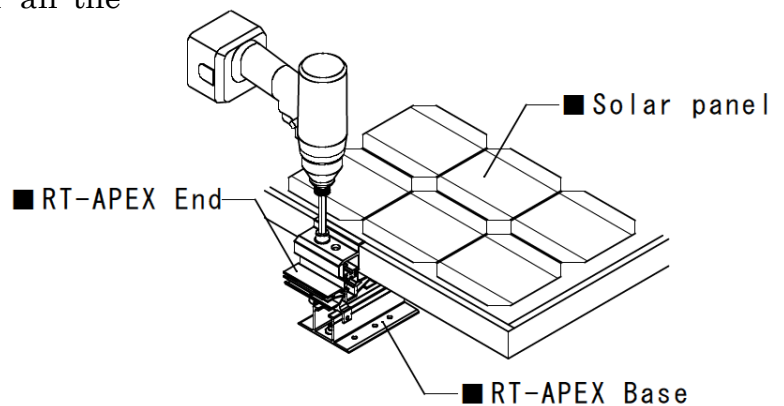

(3) Middle Clamp Installation

- ① Slide the RT-APEX Middle clamp until it is flush to the frame of the panel already installed.

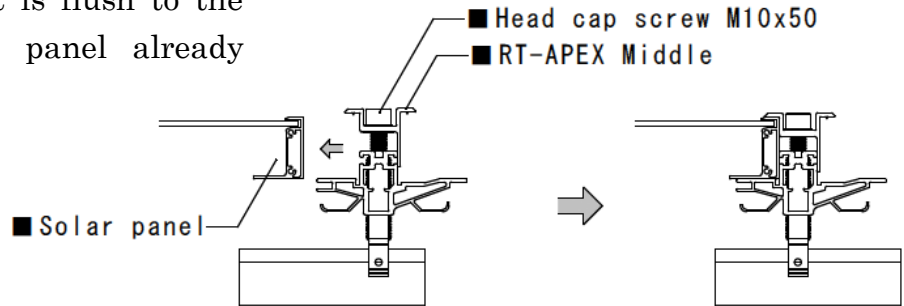

- ② Tighten the head cap screw M8x9, on the bottom side of the pillar, from side to 106 in-lbs (12 N·m) torque.

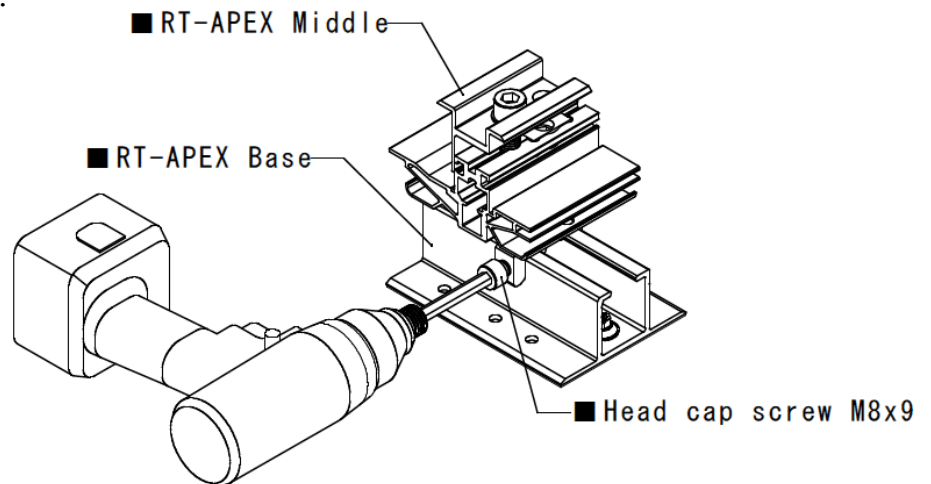

- ③ Tighten the Middle clamp head cap screw M10 to 142 in-lbs (16 N·m) or 159 in-lbs (18N·m) torque. (see appendix for the proper torque value).

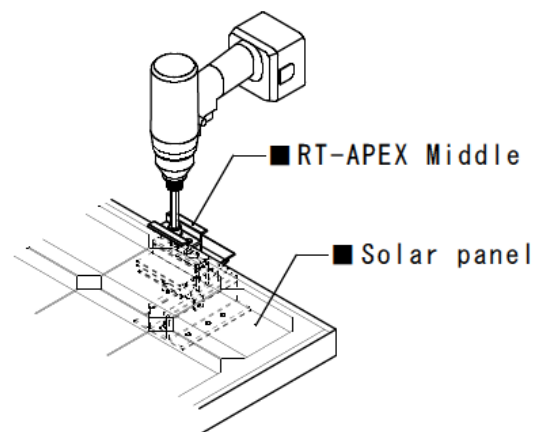

- ④ If necessary, level the height of the brackets using a hex bit socket (8 mm).

Adjusting height shall be done within the range from bottom where the Pillar hits the clamp, to the top where the pillar is flush to the top of U-D bracket. Adjustable height is up to 1" (30mm frame), 1 3/8" (46mm frame).

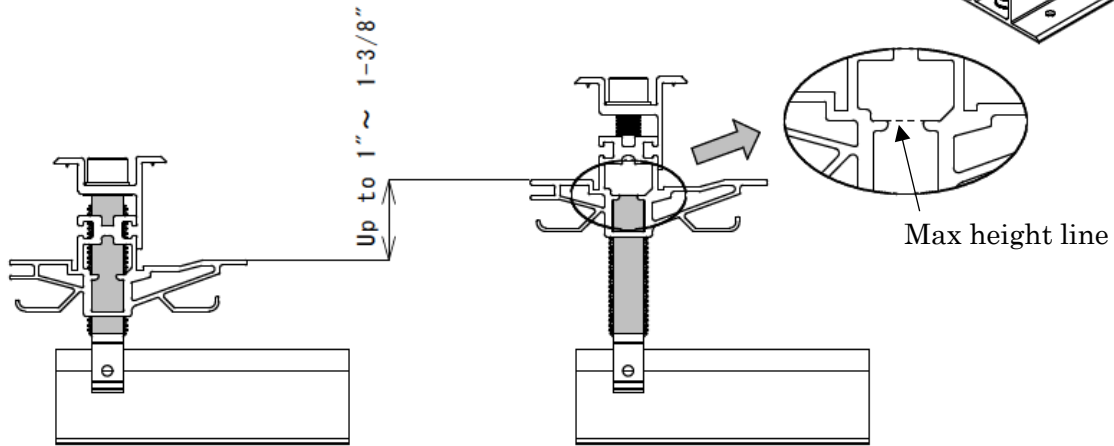
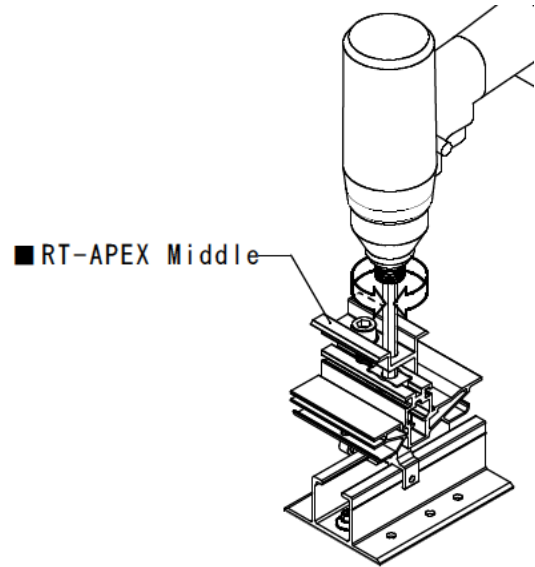

- ⑤ Slide in the PV panel from the ridge side. Make sure PV panel frame slides on the inside of the middle clamp.

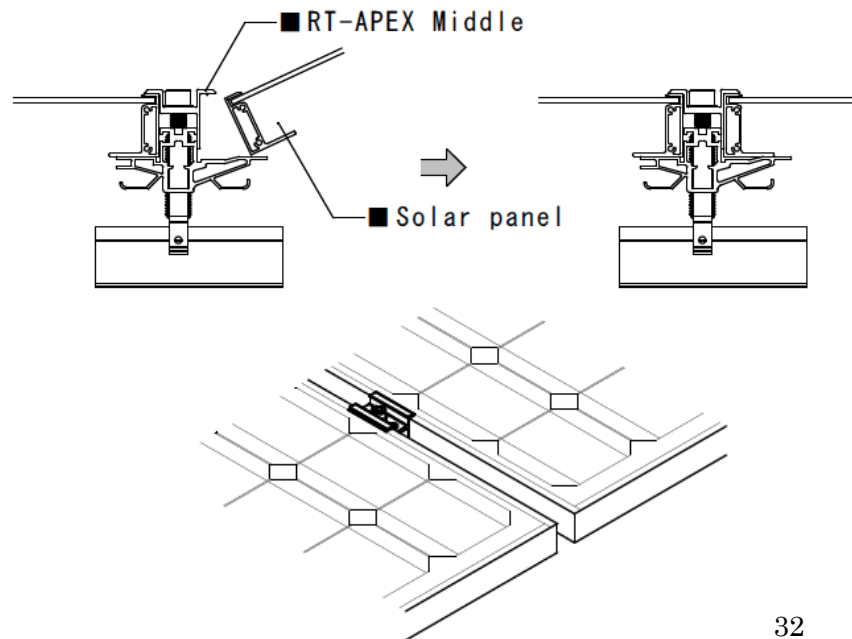

(4) Upper End Clamp (Ridge side) Installation

Note: If the ridge side (top) base Bracket was rotated 180 degrees as shown on Page 26, skip to ②' and ③'.

- ① Untighten the end clamp cap screw M10, and rotate the end clamp only. Set the screw on the same side.

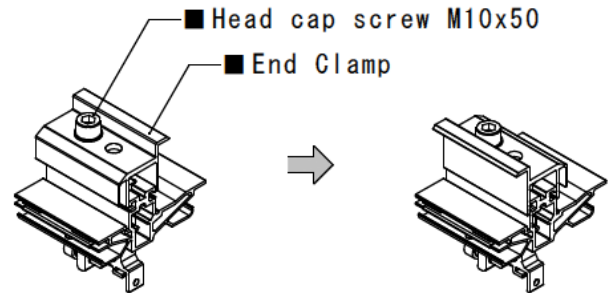

- ② Slide the RT-APEX end clamp until it is flush with the frame.

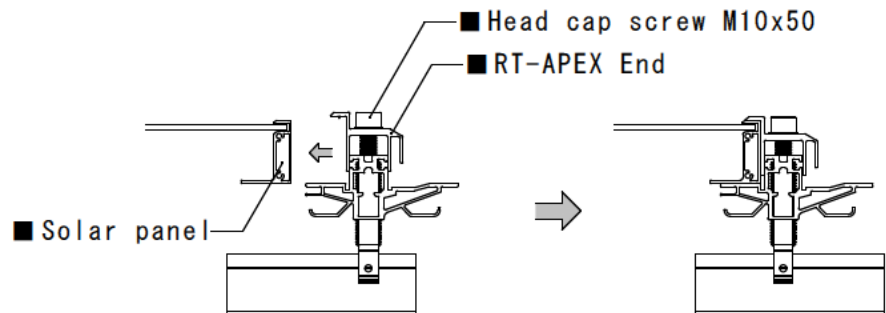

- ③ Tighten the head cap screw M8x9, on the bottom side of the pillar to 106 in-lbs (12 N·m) torque.

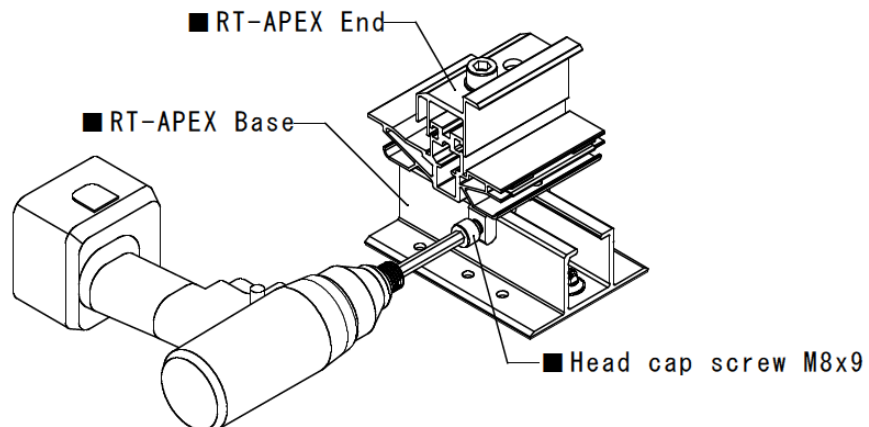

- ②' Slide the RT-APEX end clamp until it is flush with the frame.

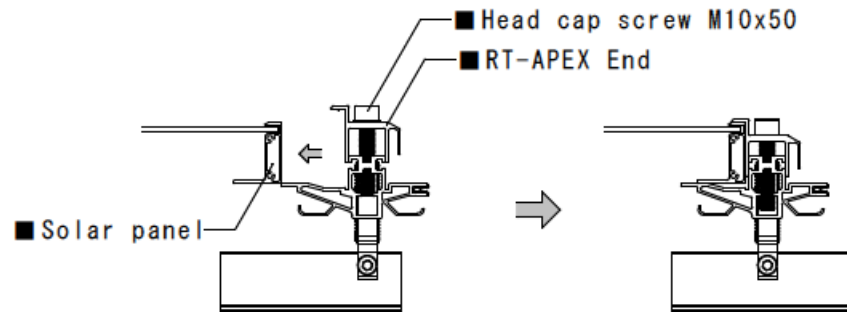

- ③' Tighten the head cap screw M8x9, on the bottom side of the pillar to 106 in-lbs (12 N·m) torque.

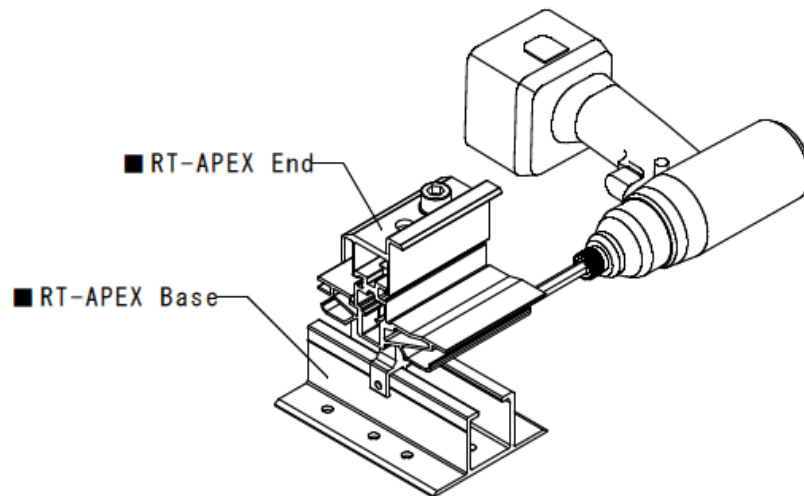

- ④ Tighten the head cap screw M10 to 142 in-lbs (16 N·m) torque or 159 in-lbs (18N·m) torque (see appendix for the proper torque value).

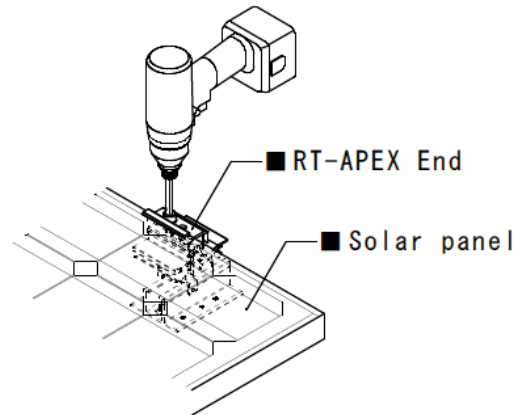

- ⑤ If necessary, level the height of the brackets using Hex wrench bit socket (8 mm).

Adjusting height shall be done within the range from bottom where the Pillar hits the clamp, to the top where the pillar is flush to the top of U-D bracket. Adjustable height is up to 1" (30mm frame), 1 3/8" (46mm frame).

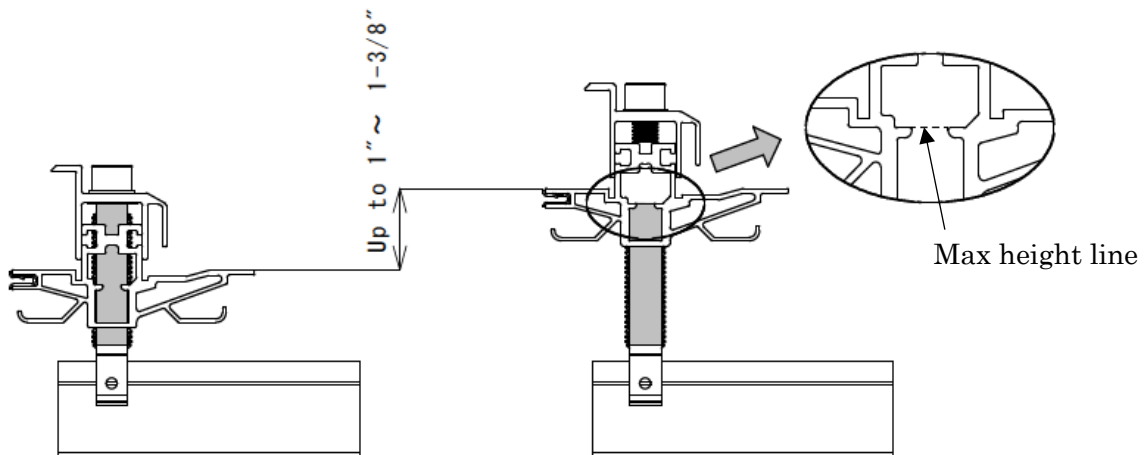

3. Eaves Cover: Skirt (Optional)

! Attention

Skirt is not recommended in areas where the ground snow exceeds 40 PSF.
 The Skirt when installed across 2 adjacent rows of PV modules will create a bonding path that can replace bonding lugs. (Details on Part E)

(1) Install the first row

- ① After alignment of the first row, put in Eaves cover to U-D Bracket.

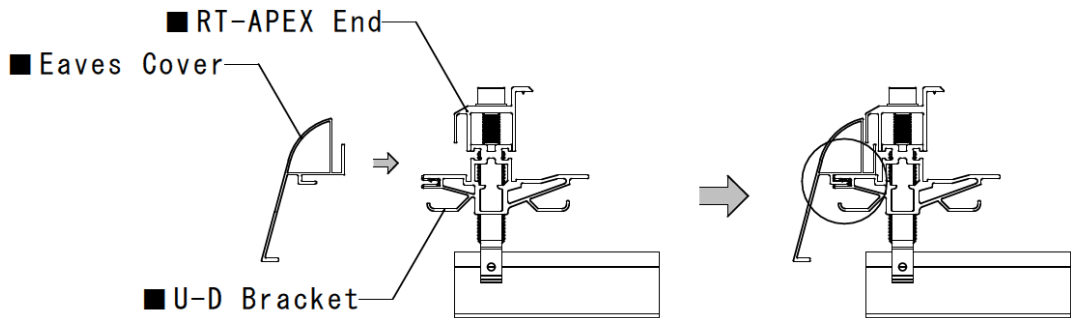

Note: Eaves cover; Skirt must fit in the channel where Bonding clip is installed at U-D bracket as it shown on picture.

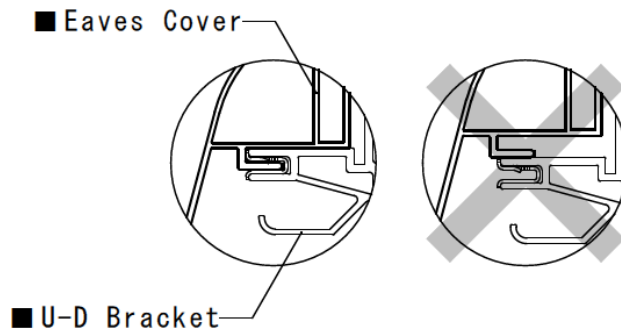

- ② Set the Panel in place and adjust its position, then tighten the Head cap screw M10 to 142 in-lbs (16 N·m) or 159 in-lbs (18N·m) torque (see appendix for the proper torque value).

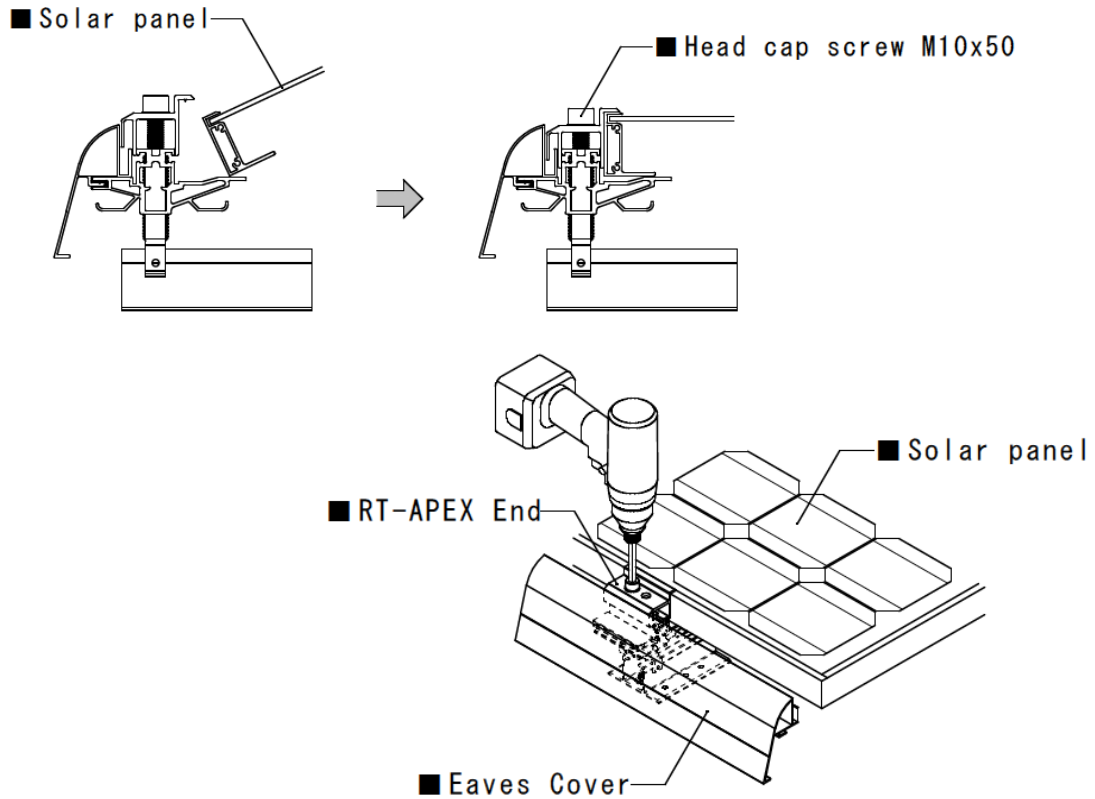

- ③ Open 1/8 inch (3mm) between Eave covers next to each other.

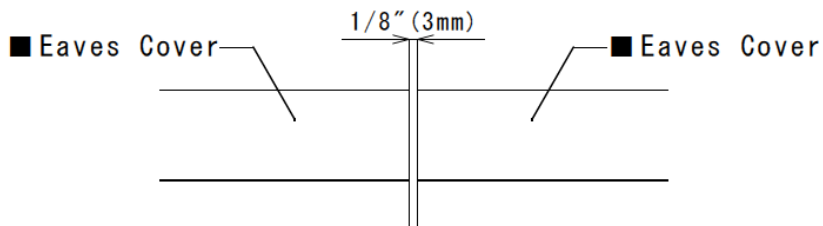

Back to “(3) Middle Clamp Installation” on Page 31.

4. Skirt Bonding Splice: Eaves Cover Joint (Optional)

- ① Slide in Skirt Bonding Splice to the edge of Eaves Cover. Skirt Bonding Splice has a tooth which shall be face down to bottom. Please slide in the Skirt Bonding Splice until the teeth scratches the side wall. You may use rubber mallet to install it.

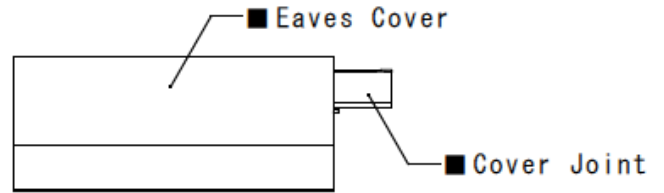
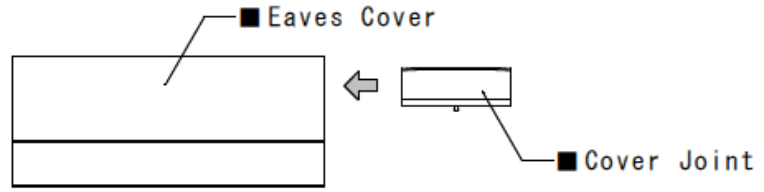

! Attention
 Make sure the teeth facing down to bottom of Skirt.

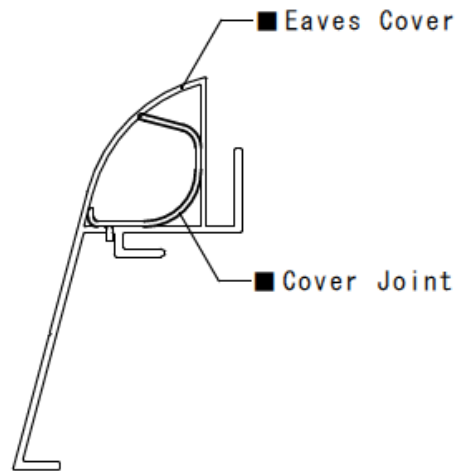
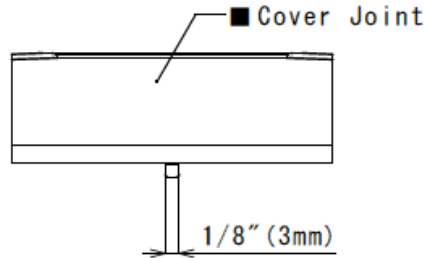

- ② There is a 3mm gap between each Skirt, and the teeth create this 3mm gap once installed correctly.

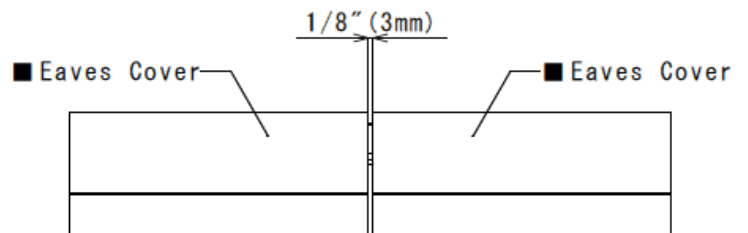
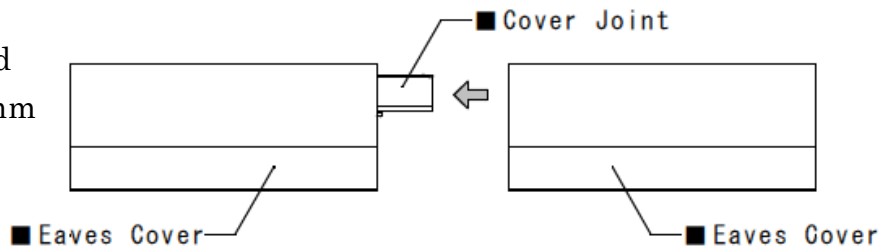

5. Skirt End Cap (Optional)

- ① Place and secure the Skirt End Cap to the side of Eaves Cover.

! Attention
 End Cap kit include Left and Right Cap. Please make sure to install correct side to each end of Skirt.

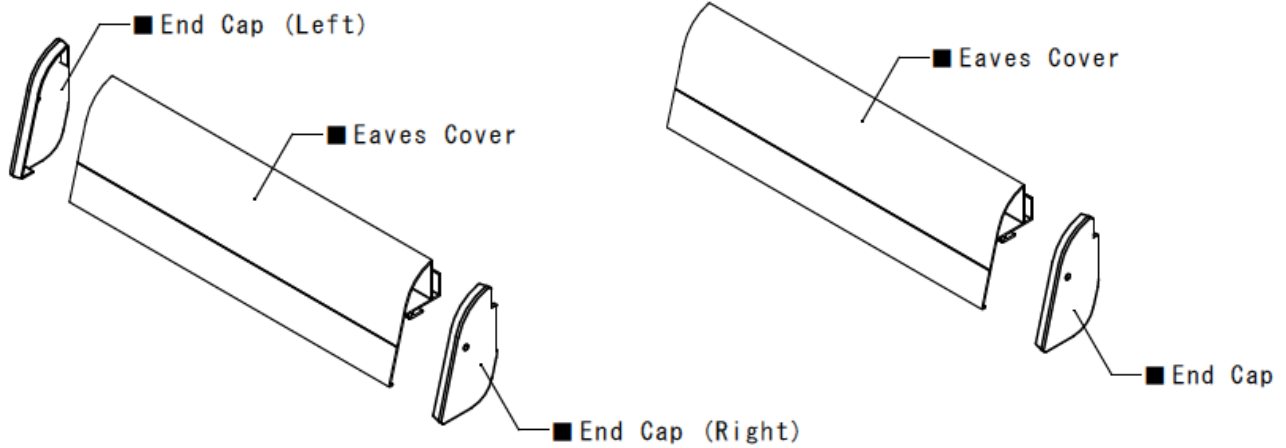

- ② Use Tapping Screw M4 x 16 to secure the End Cap.

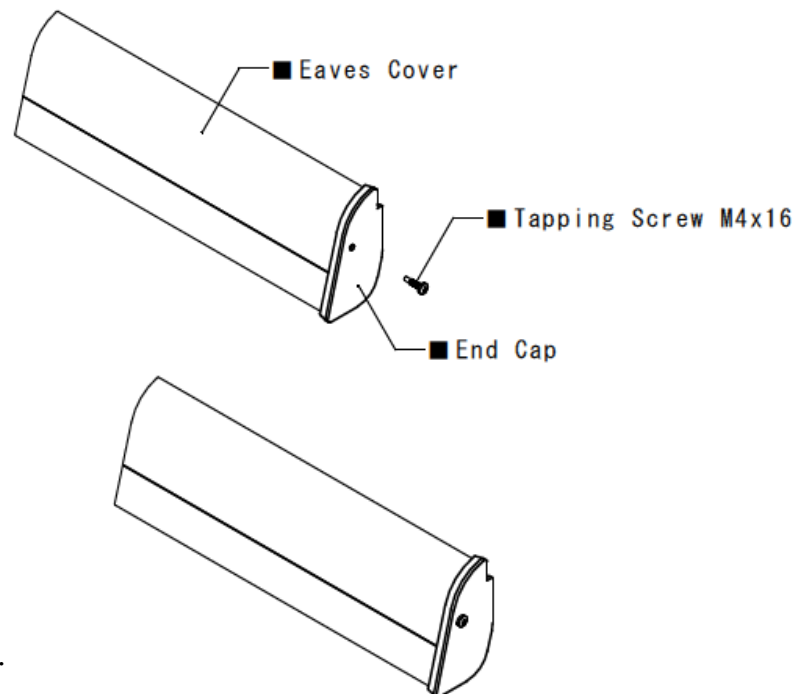

- ③ Please install on both sides.

6. Side Screw (Optional)

- ① The optional side screw M4 x16 SDST increases the load capacity specially in heavy snow locations. It allows for an increased span. Consult the PE stamped letters for the span values marked with *. Use Hex socket drive (7 mm) to set the screw M4×16 SDST as showed in picture below.

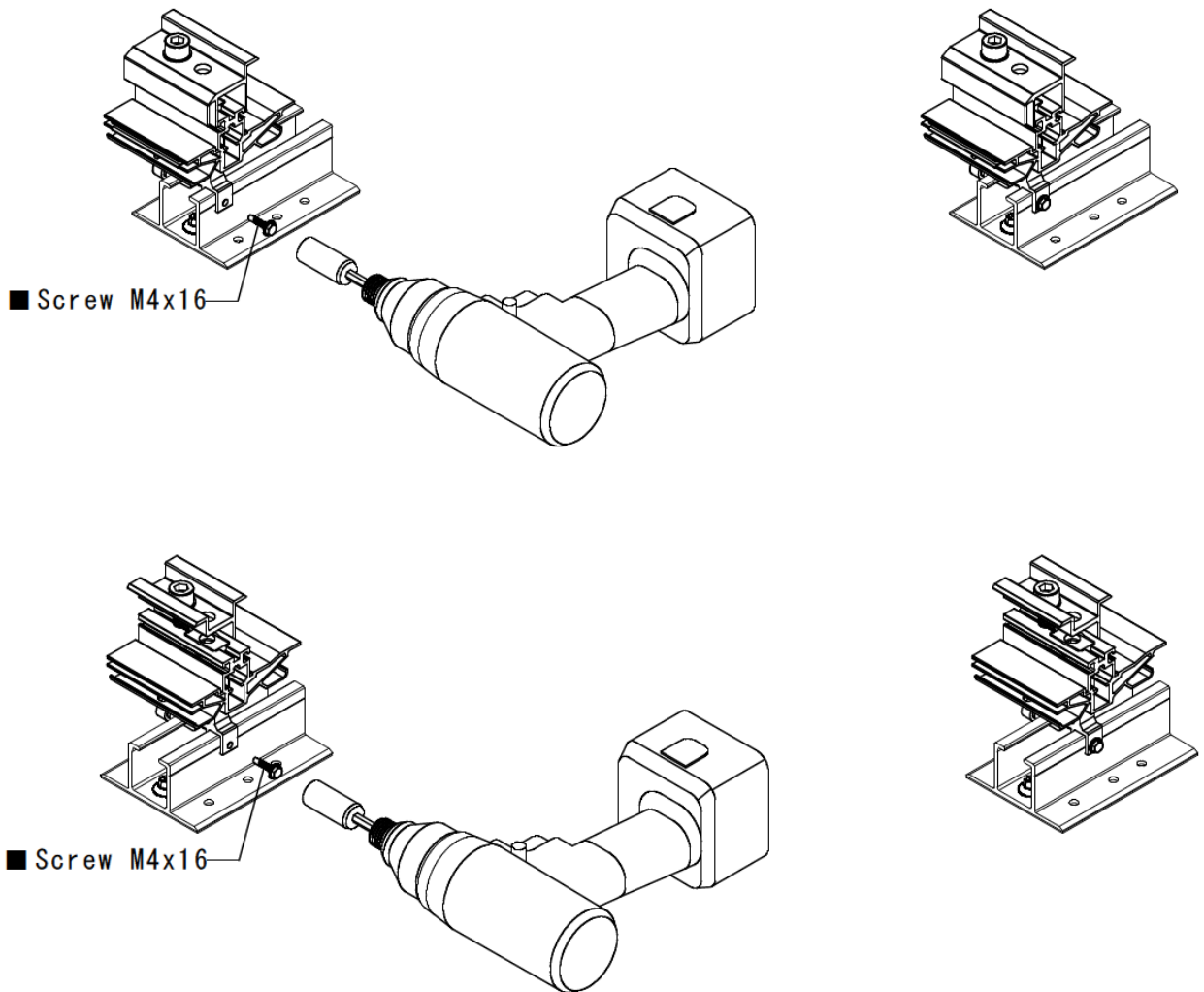

7. SUMO Clip (Optional)

① Once the Pillar is set in place with the M8x9 screw, the SUMO clip can slide all the way in.

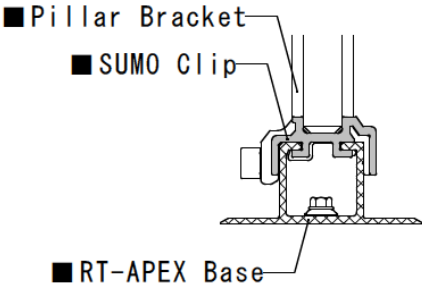
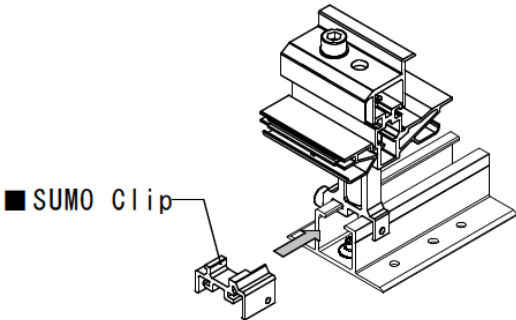

② Use M4x16 SDST screw to fix the SUMO Clip and Pillar Bracket together on both sides. First set the side overlapping the Pillar Bracket since the M4x16 SDST screw will have to match the hole on the Pillar Bracket.

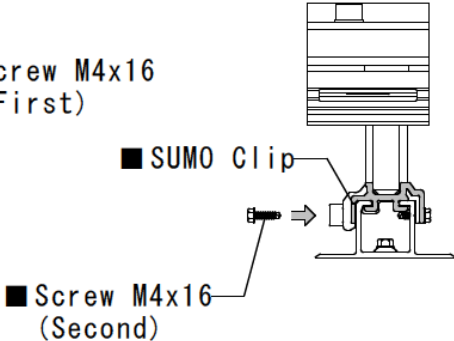
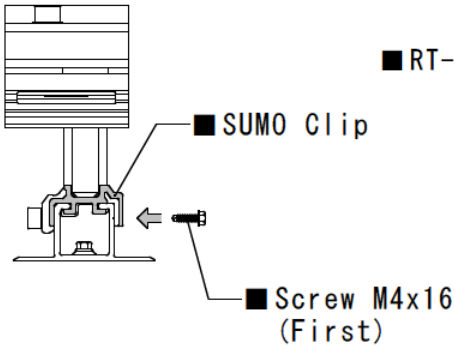

! Attention

Please make sure the SUMO clip and the Pillar are fixed together using 2 x M4-16 SDST screws. Verify the increased max. span from the PE Stamped Letters.

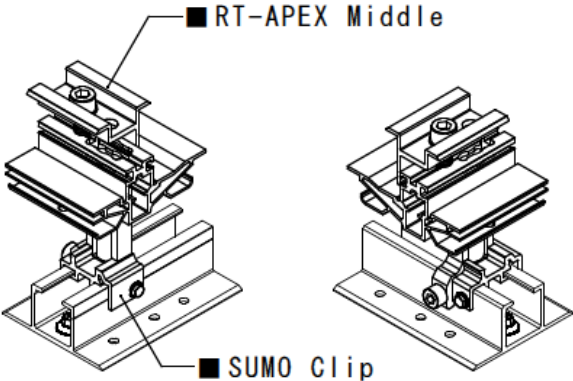
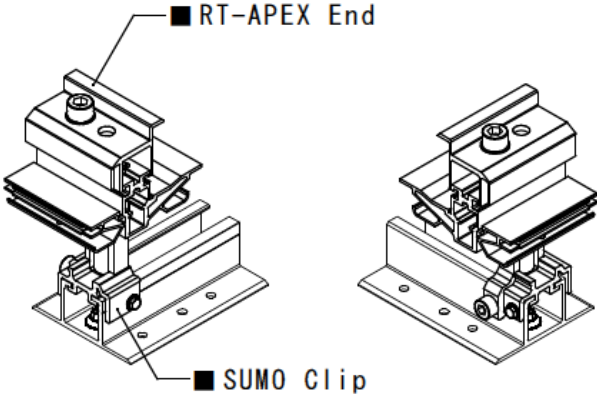

PART C: Splice Installation

! Attention

Both supported splice and floating splice must be an approved method and included in the PV module manufacturer installation instructions.

1. Installation of Splice Brackets

(1) Brackets Layout (Including Splice)

a) Installation on the RAFTER

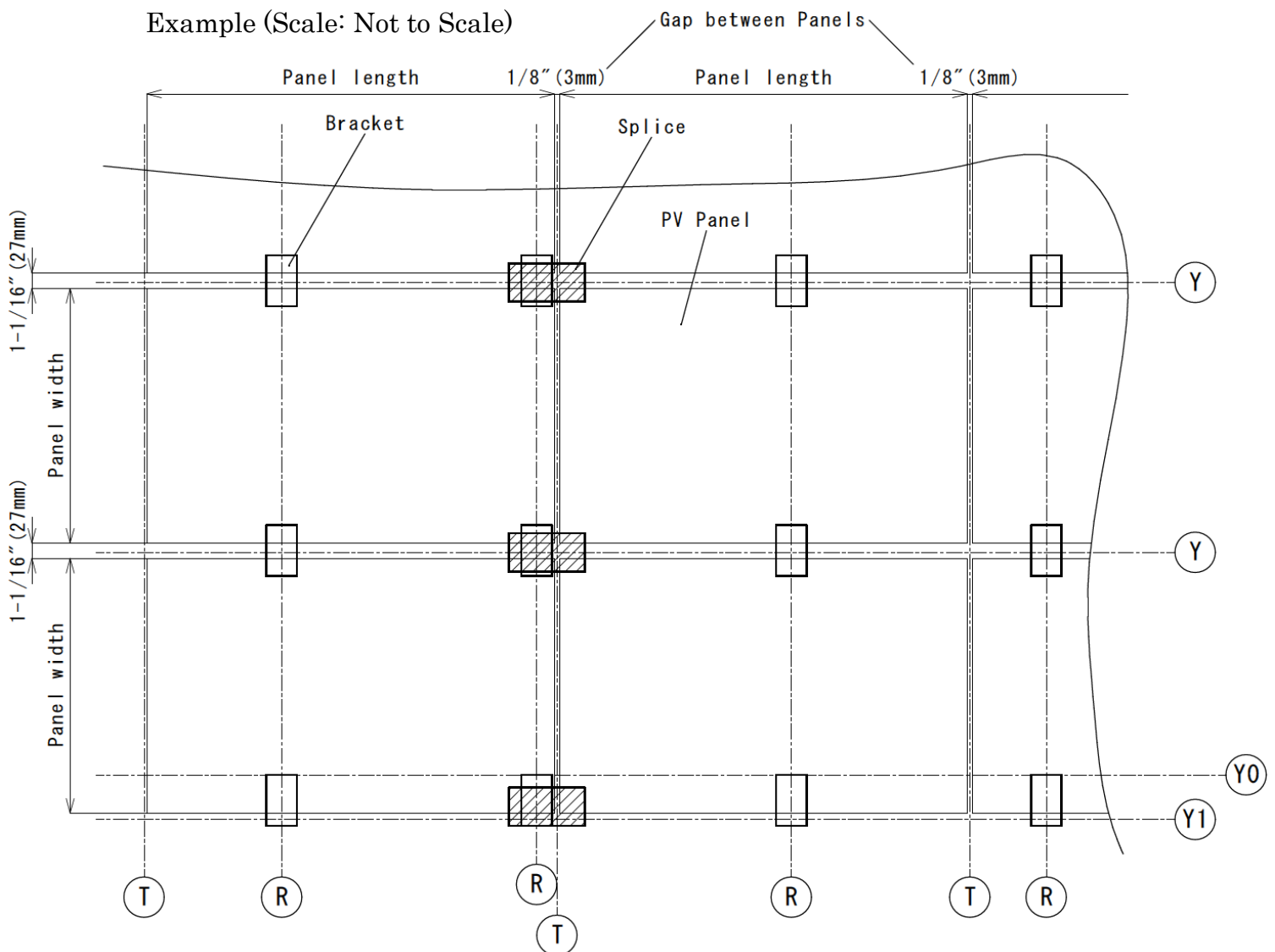

Note: Minimum distance $1/8''$ (3 mm) between panels.

b) Installation on the **DECK** ①

Example (Scale: Not to Scale)

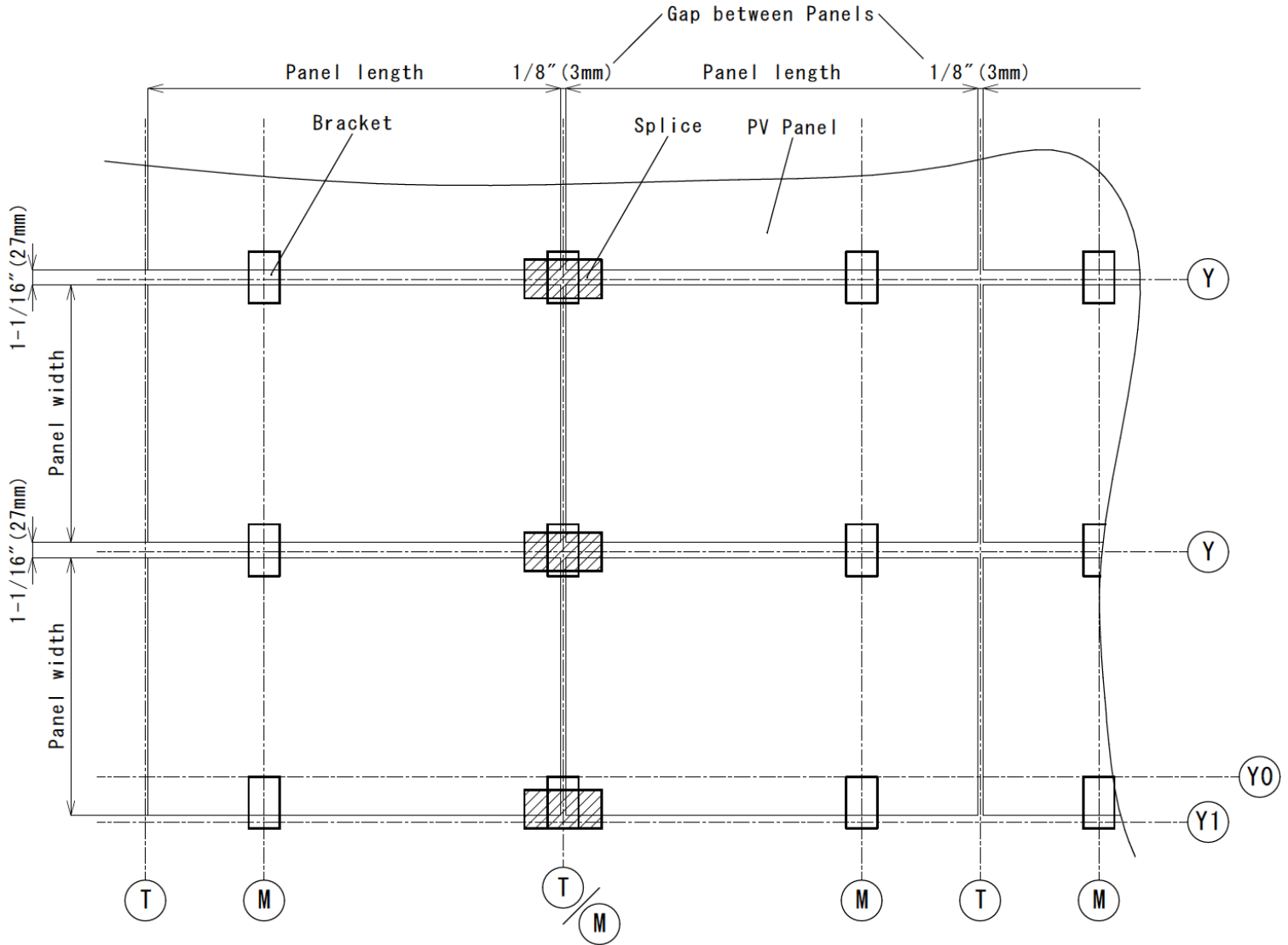

b) Installation on the **DECK** ② (Floating Splice)

Example (Scale: Not to Scale)

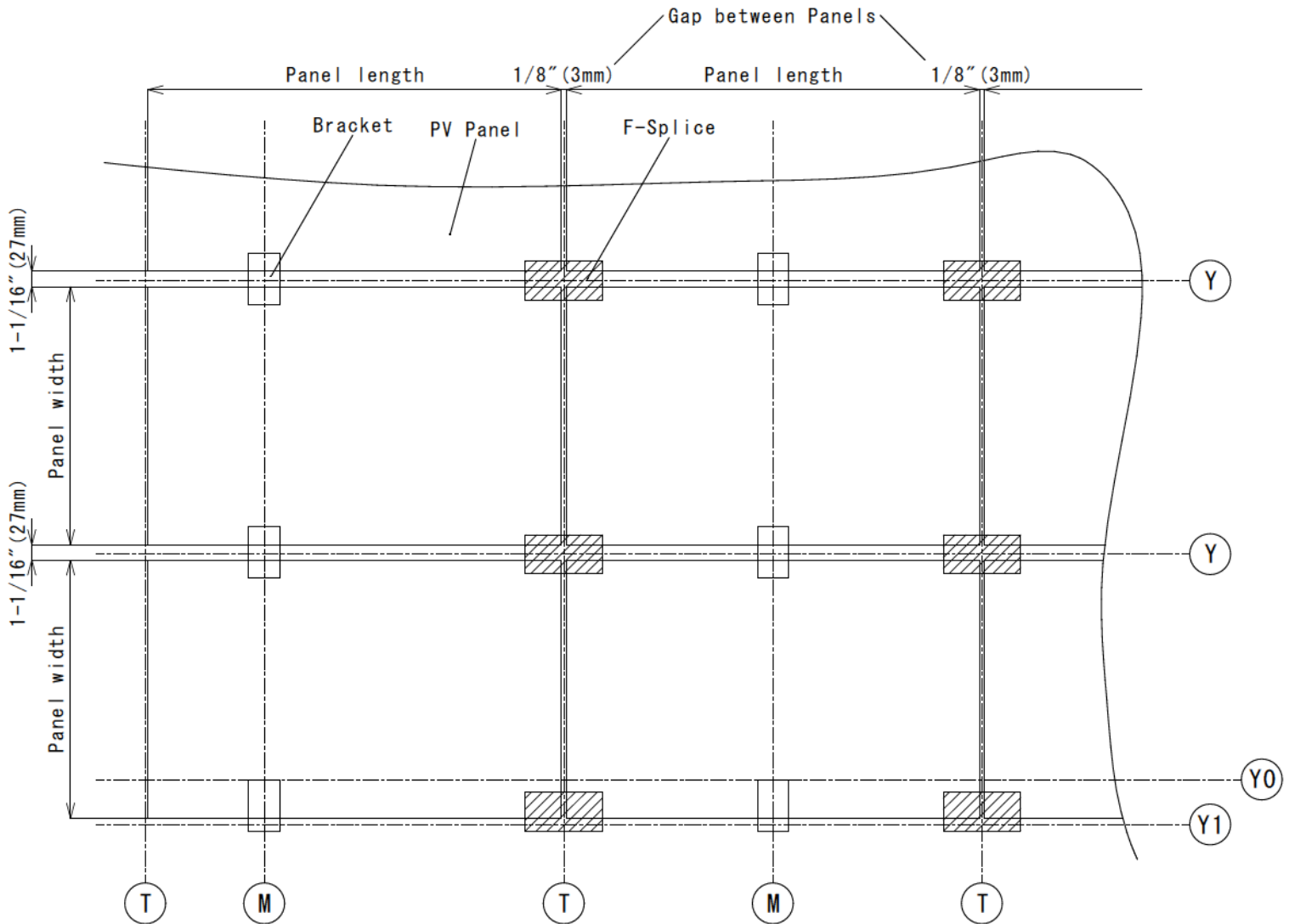

Note: It is an option to install a Floating Splice (no roof connection) based on the PV module installation instructions and the structural analysis (PE Stamped letters provided). Please refer to Page 7 for Floating Splice installation.

c) Splice Installation Area

- ① If the Splice is installed at the corner of the module, the module frame must sit at least 1-3/16" (30mm) away from the edge of the clamp.

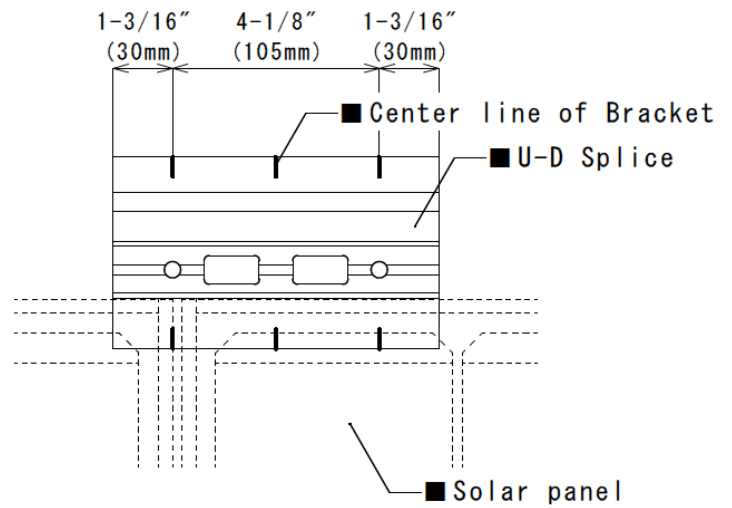

PV panel corner on the left side

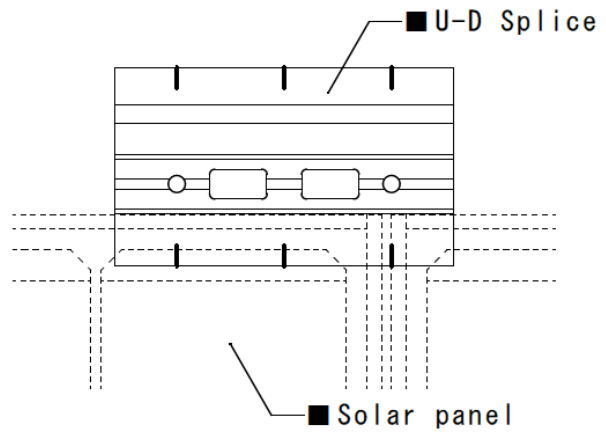

PV panel corner on the right side

Note : When designing for the splice, notice its center is offset by 7/8" (22mm) from the R/M line, when the Base Bracket is installed at the center of the R/M line.

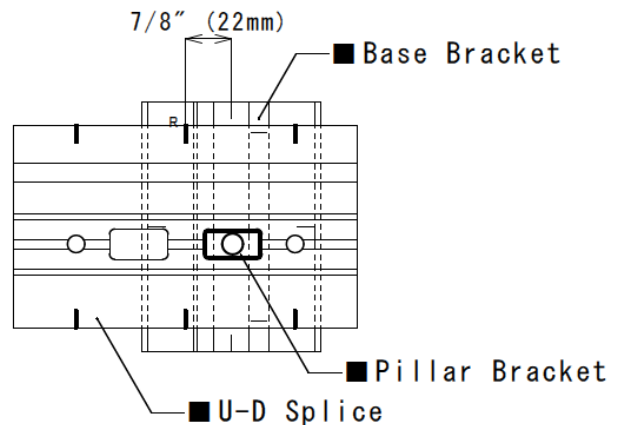

- ② Switching the sides of the pillar will allow a 45mm lateral adjustment. The edge of the PV module can be mounted within 3" from the R/M lines (as shown).

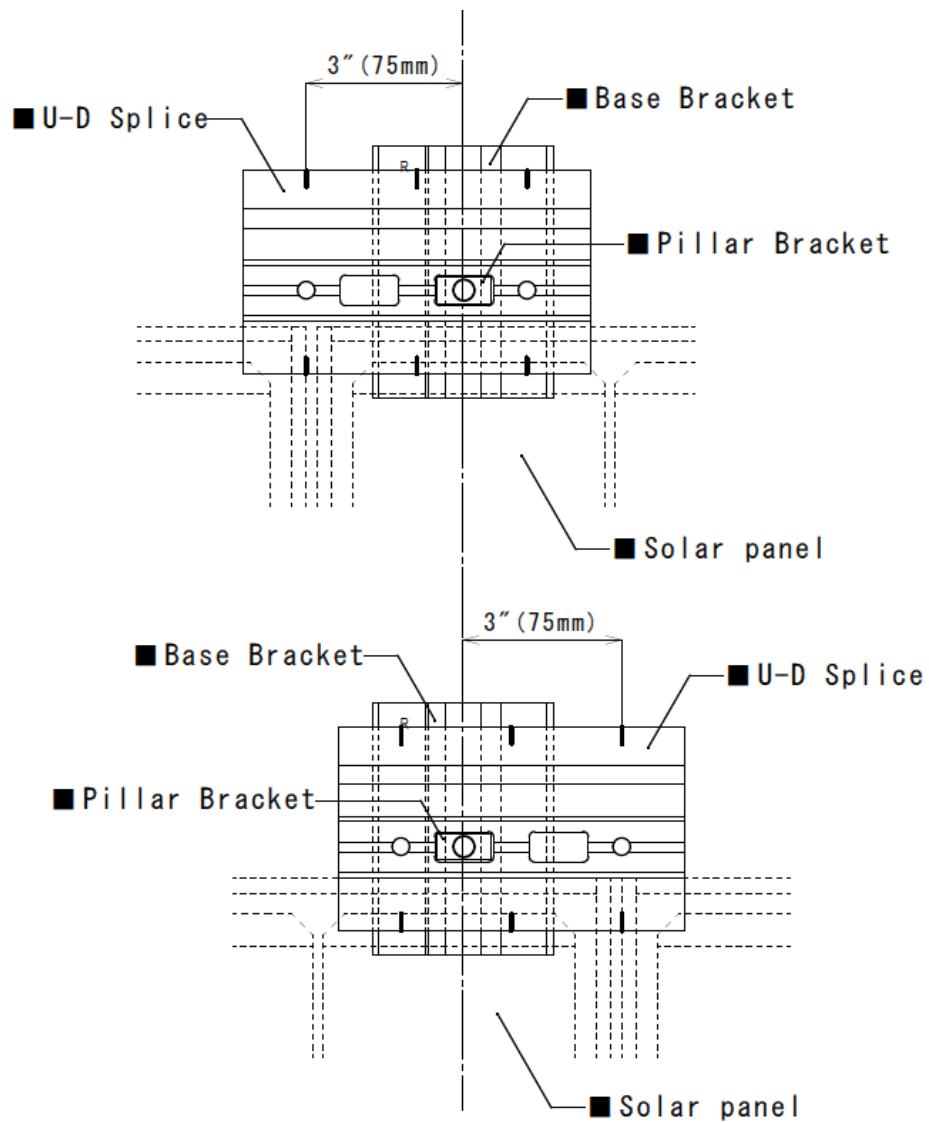
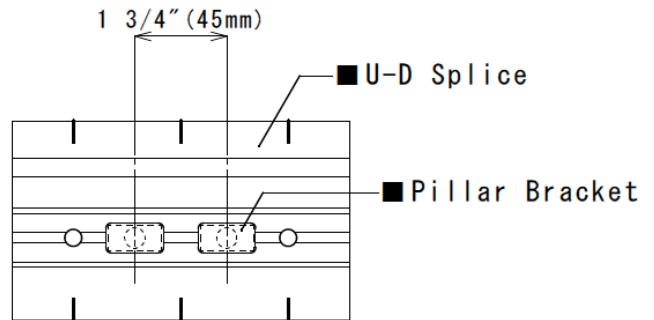

(2)-1 Floating Splice Installation on the First Row (eaves side)

※ **Install the End splice for the first and the ridge rows installation.**

(First Row ; A base is needed on the eaves side)

- ① End Floating Splice shall be installed with Base Bracket for the first Row.

(Also shown on Pgs. 49 & 53)

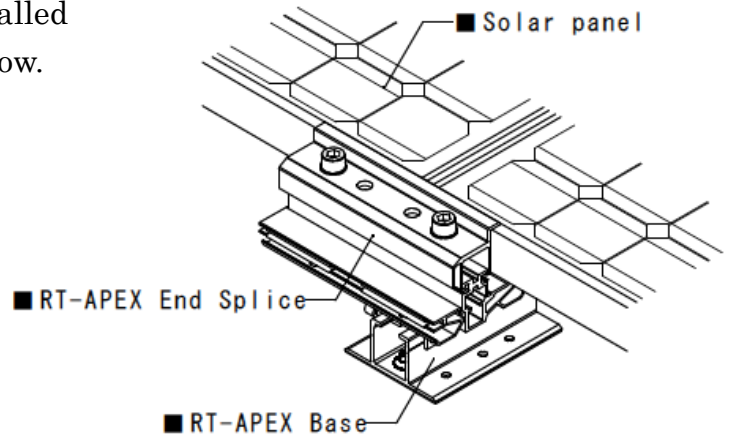

※ **In case of the floating splice with the skirt between two mounts.**

(A base is not needed on the eaves side)

- ① A floating splice may be used once a skirt is installed between two adjacent PV modules. Verify PV module installation manual specifications for the “Floating splice”. The maximum span between bases must be verified with the PE stamped letters and the max. grd. snow allowed for the skirt is 40 PSF.

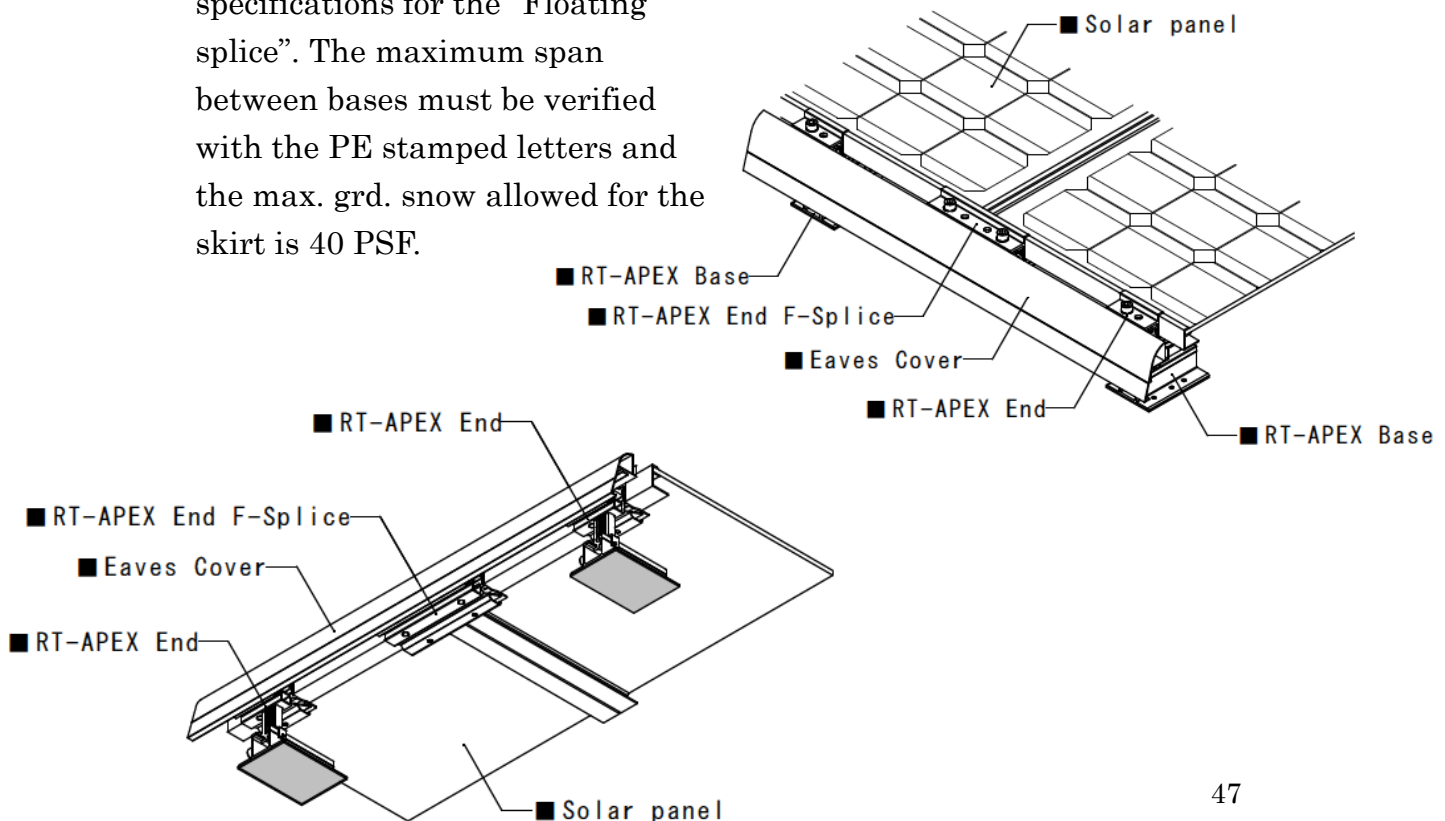

- ② The Ridge (top row) Floating Splice doesn't need a base and shall be installed by rotating the clamp 180 degrees (The flat section of the UD bracket in full contact with PV module frame)

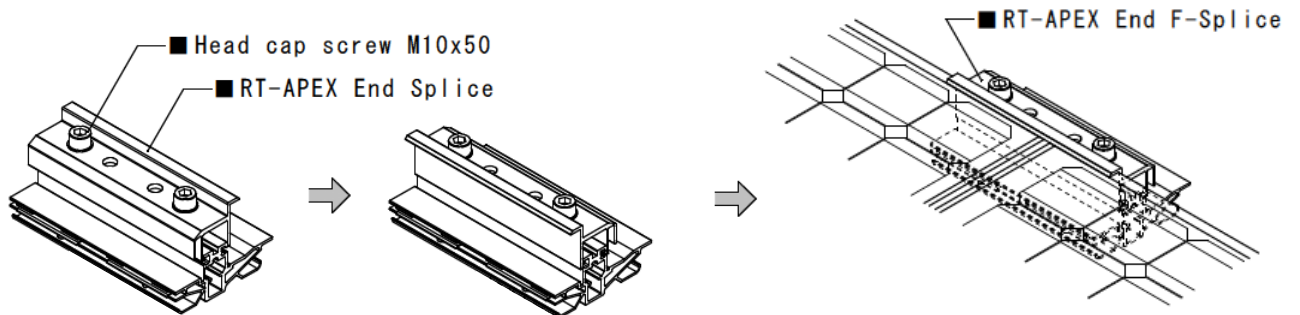

(2)-2 Middle Floating Splice Installation

- ① After first row is installed, Middle Floating Splice can be installed all the way to the ridge with no need of a base. (Detail is shown from Pgs. 50 to 52 Middle Splice Installation)

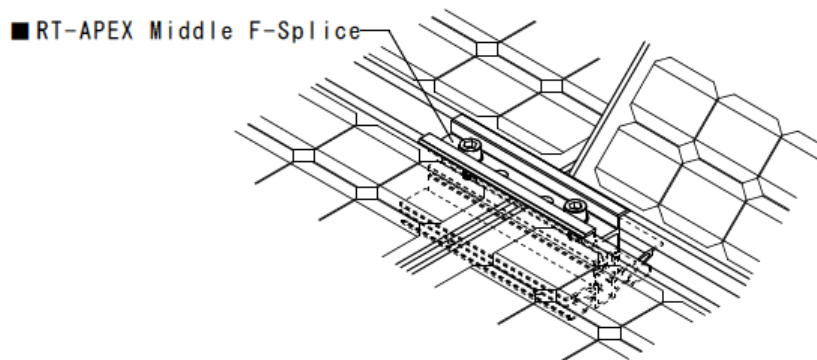

(3) End Splice and the First Row Panel Installation

- ① Place the PV panel on the U-D Splice.

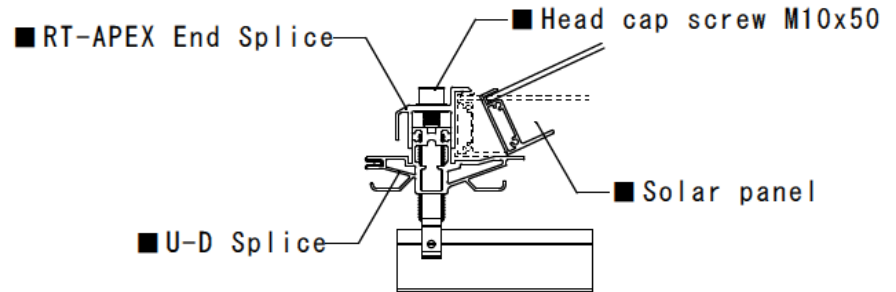

- ② Make any adjustment then tighten the Head cap screw M10 to 142 in-lbs (16 N·m) or 159 in-lbs (18N·m) torque (see appendix for the proper torque value).

- ③ Repeat ① and ② for all the first row panels.

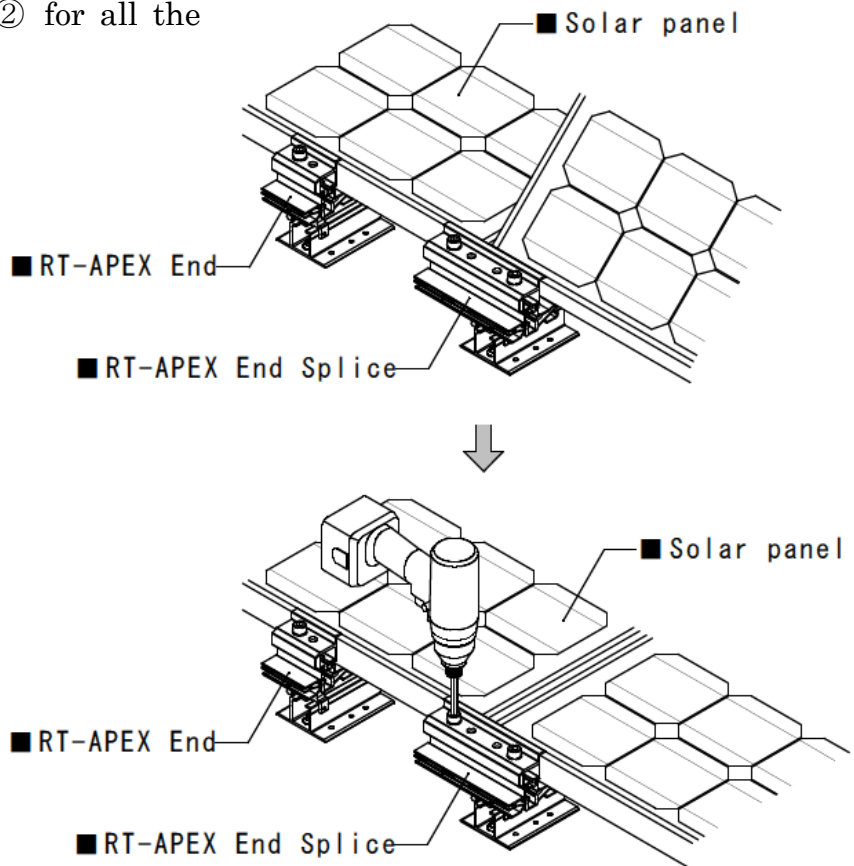

(4) Middle Splice Installation

- ① Slide the RT-APEX Middle Splice until it is flush to the frame of the panel already installed.

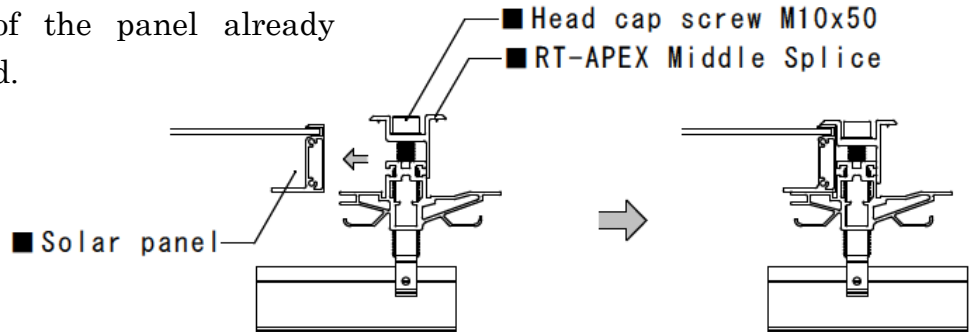

- ② Tighten Head cap screw M8x9, on bottom side of Pillar, from side with 106 in-lbs (12 N·m) torque.

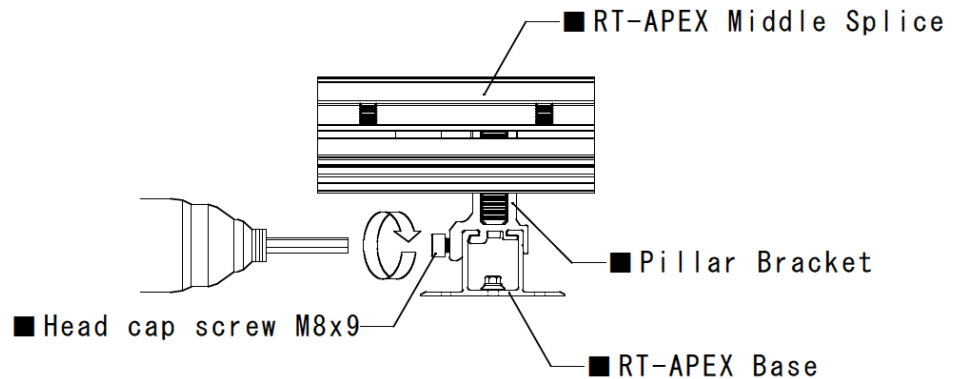

! Attention

Maximum Torque value for the head cap M8x9 is 106 in-lbs (12 N·m).

- ③ Tighten the Head cap screw M10 to 142 in·lbs (16 N·m) or 159 in·lbs (18N·m) torque (see appendix for the proper torque value).

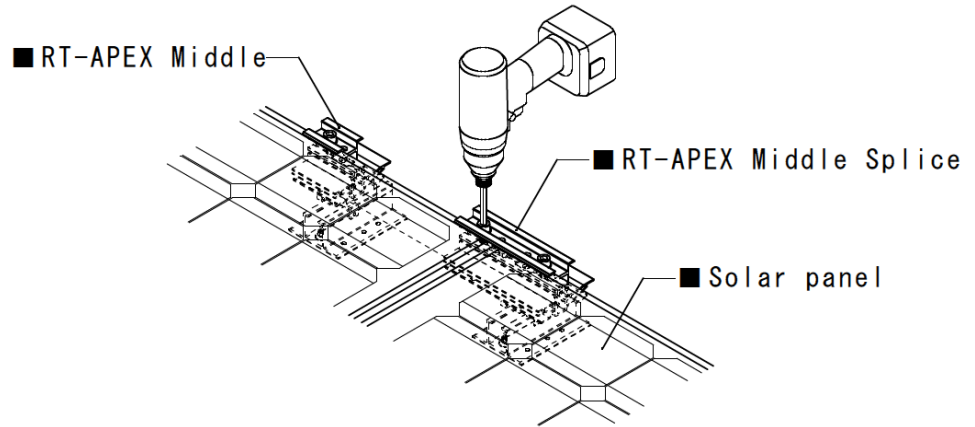

- ④ If necessary, level the height of the brackets using Hex wrench bit socket (8 mm).

Adjusting height shall be done within the range from bottom where the Pillar hits the clamp, to the top where the pillar is flush to the top of U-D bracket. Adjustable height is up to 1" (30mm frame), 1 3/8" (46mm frame).

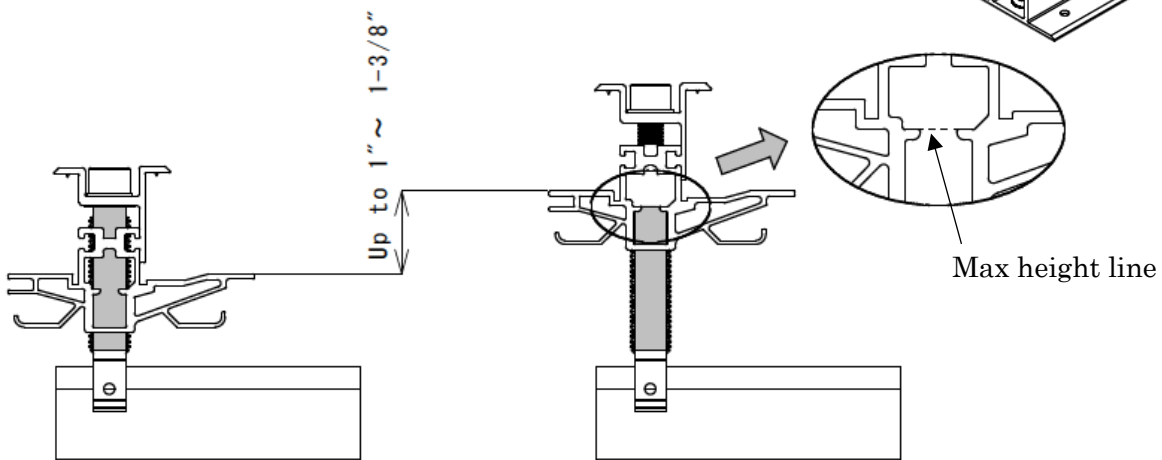
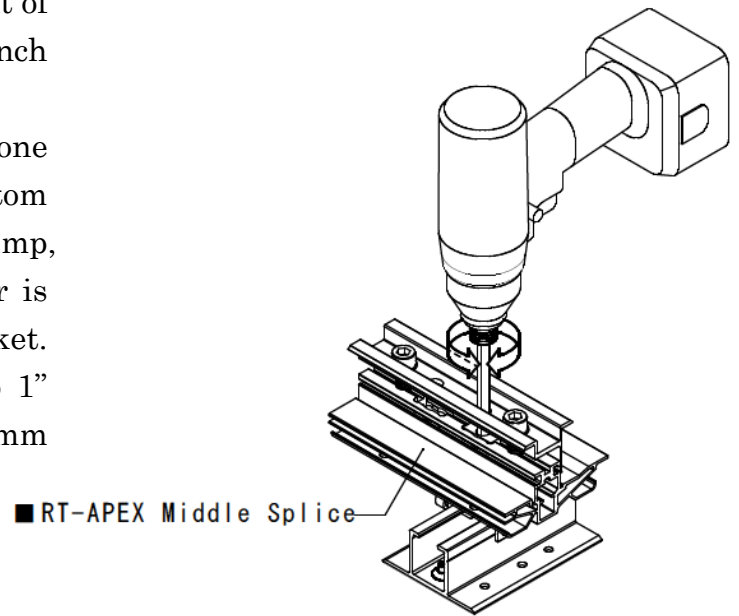

- ⑤ Slide in PV panel from ridge side. Make sure PV panel frame fits to the inside of the Middle clamp.

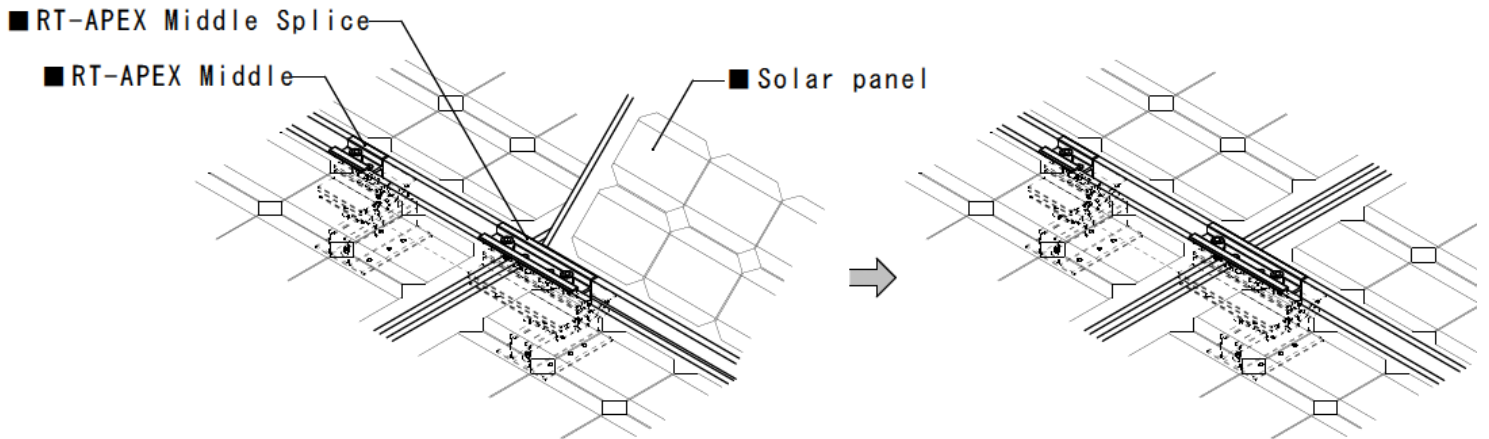
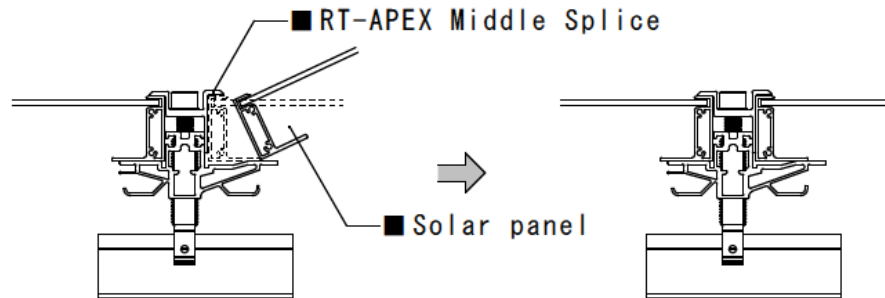

(5) Upper (Ridge side) End Splice Installation

Note: If the ridge side (top) base Bracket was rotated 180 degrees as shown on Page 26, skip to ②' and ③'.

- ① Untighten End Splice Clamp Head cap screw M10, and rotate the clamp 180 degrees.

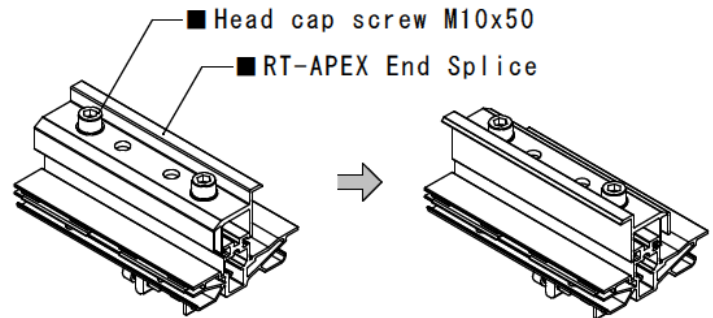

- ② Slide the RT-APEX End Splice until it is flush to the frame of the panel already installed.

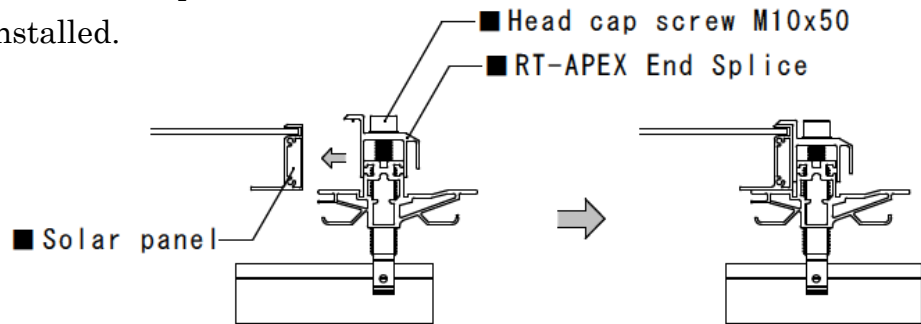

- ③ Tighten the head cap screw M8x9, on the bottom side of the Pillar, to 106 in-lbs (12 N·m) torque.

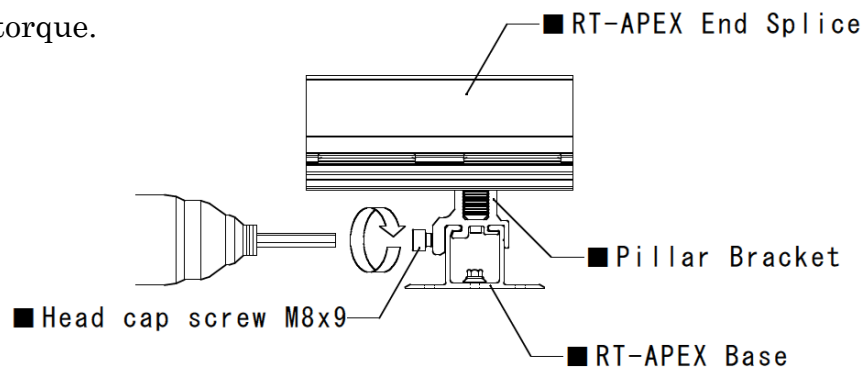

- ②' Slide the RT-APEX End Splice until it is flush to the frame of the panel already installed.

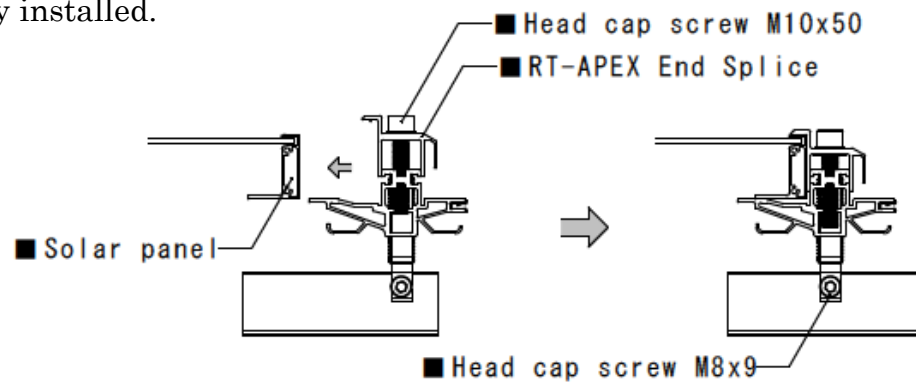

- ③' Tighten the head cap screw M8x9, on the bottom side of the Pillar, to 106 in-lbs (12 N·m) torque.

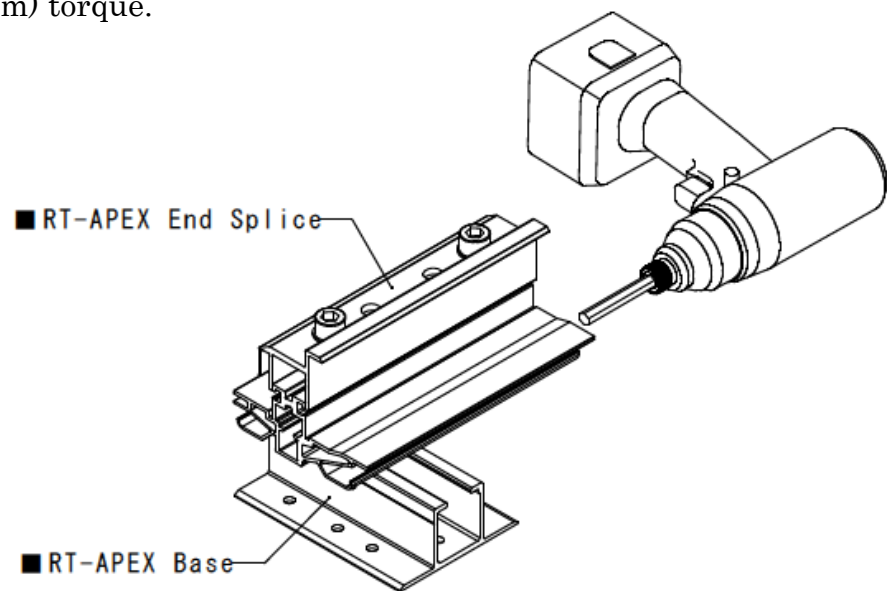

- ④ Tighten the Head cap screw M10 to 142 in·lbs (16 N·m) or 159 in·lbs (18N·m) torque (see appendix for the proper torque value).

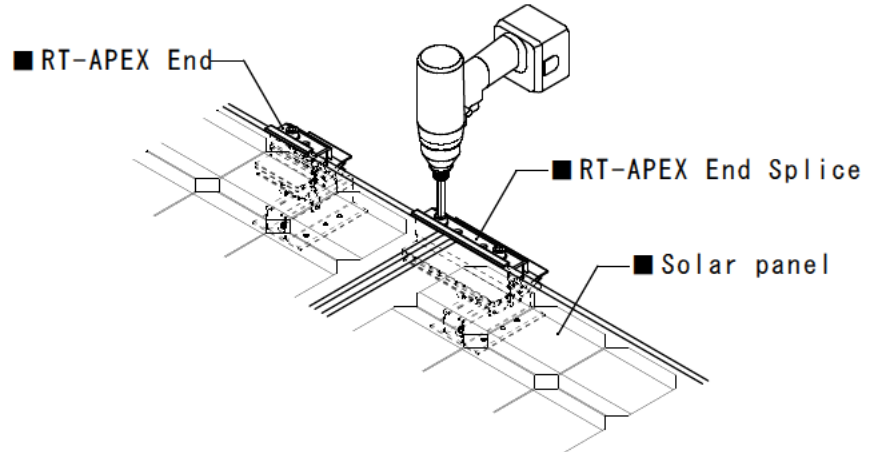

- ⑤ If necessary, level the height of the brackets using Hex wrench bit socket (8 mm).

Adjusting height shall be done within the range from bottom where the Pillar hits the clamp, to the top where the pillar is flush to the top of U-D bracket. Adjustable height is up to 1" (30mm frame), 1 3/8" (46mm frame).

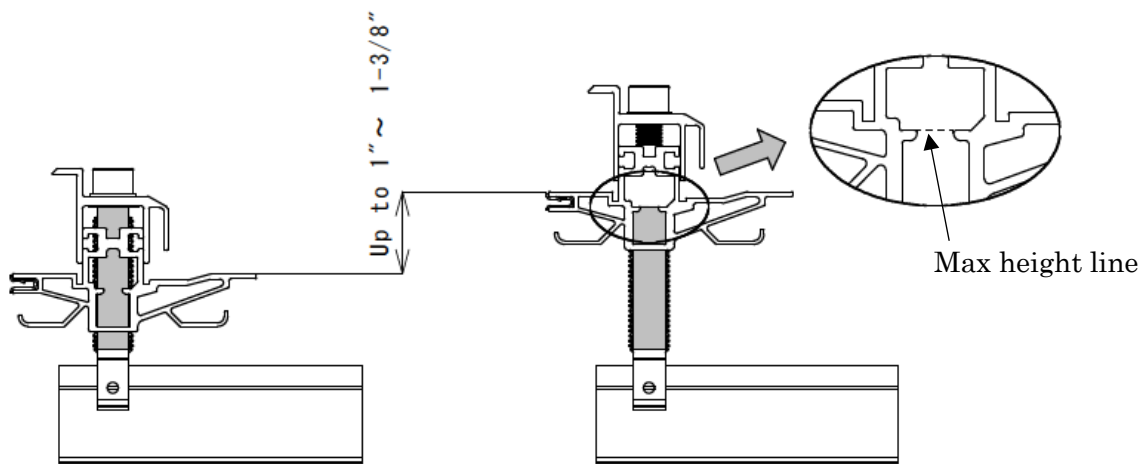

PART D: Portrait Layout

1. Installation of Brackets

(1) Brackets Layout

a) Installation on the RAFTER

Example (Scale: Not to Scale)

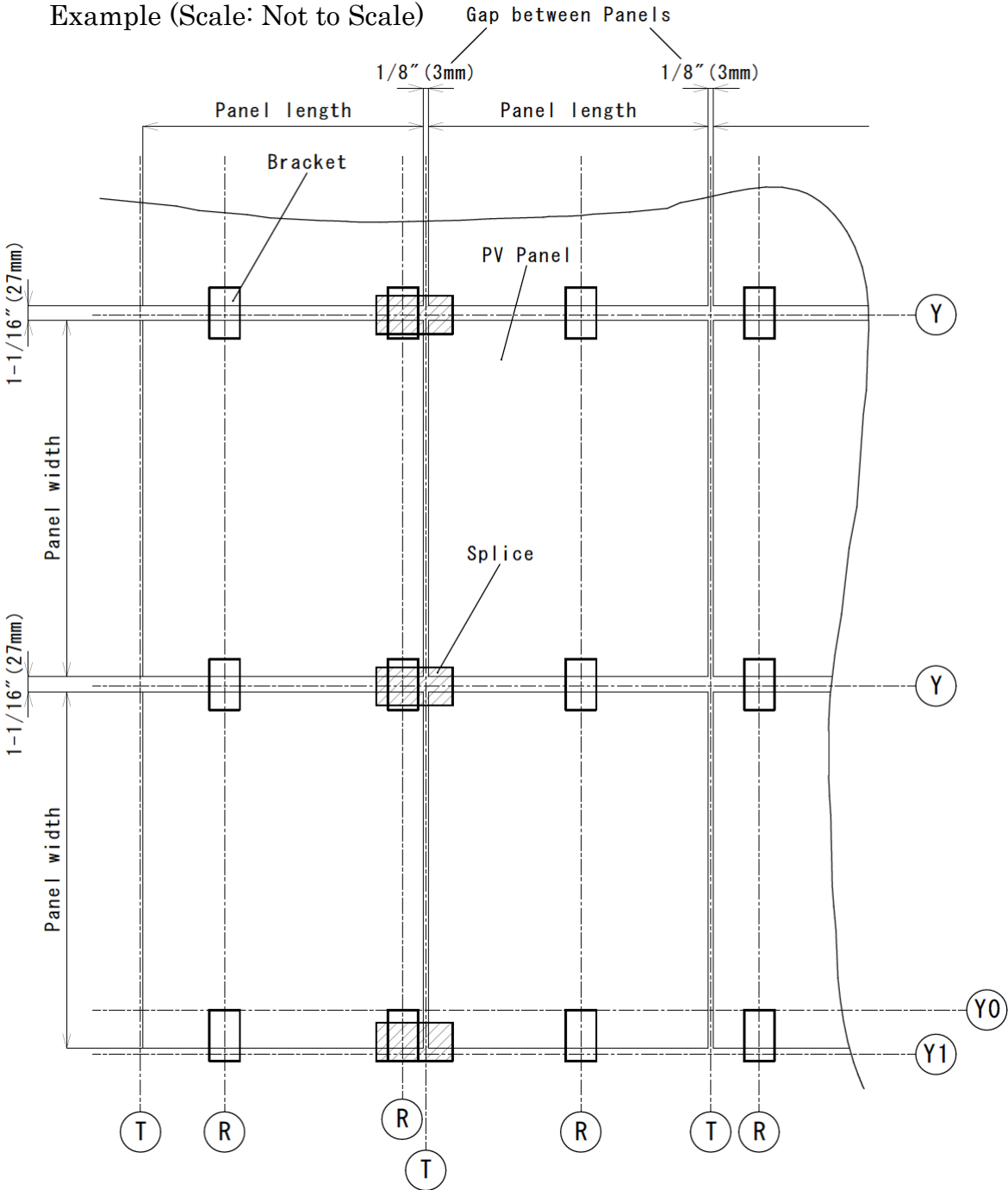

Note: Minimum distance $1/8'' (3\text{ mm})$ between panels.

Note: The Base direction to install PV panel in Portrait is same direction as PV panel in Landscape.



Attention

Supported splice must be an approved method and included in the PV module manufacturer installation instructions.

b) Installation on the DECK ①

Example (Scale: Not to Scale)

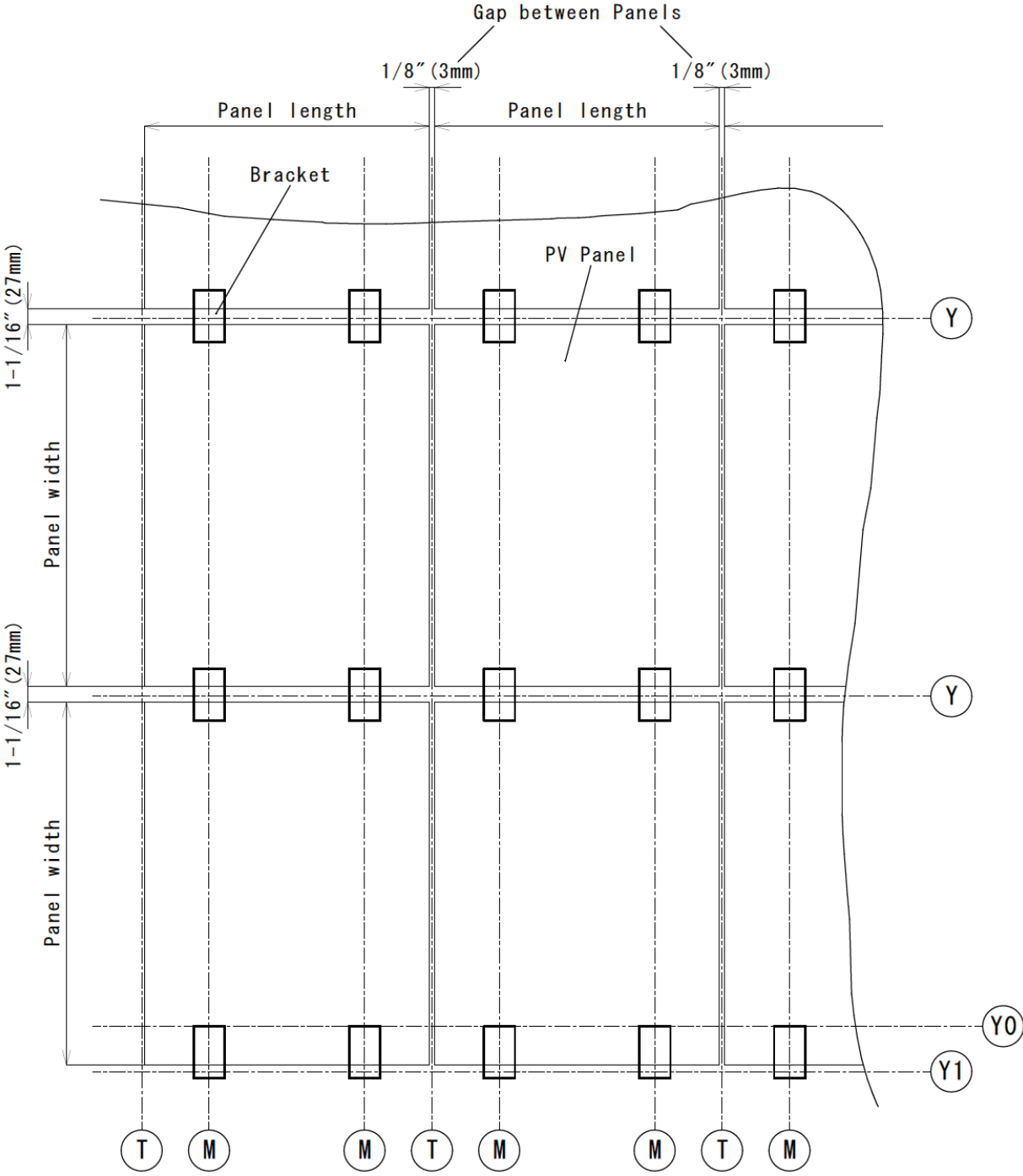

Note: Minimum distance $1/8'' (3\text{ mm})$ between panels.

b) Installation on the **DECK ②** (Floating Splice)

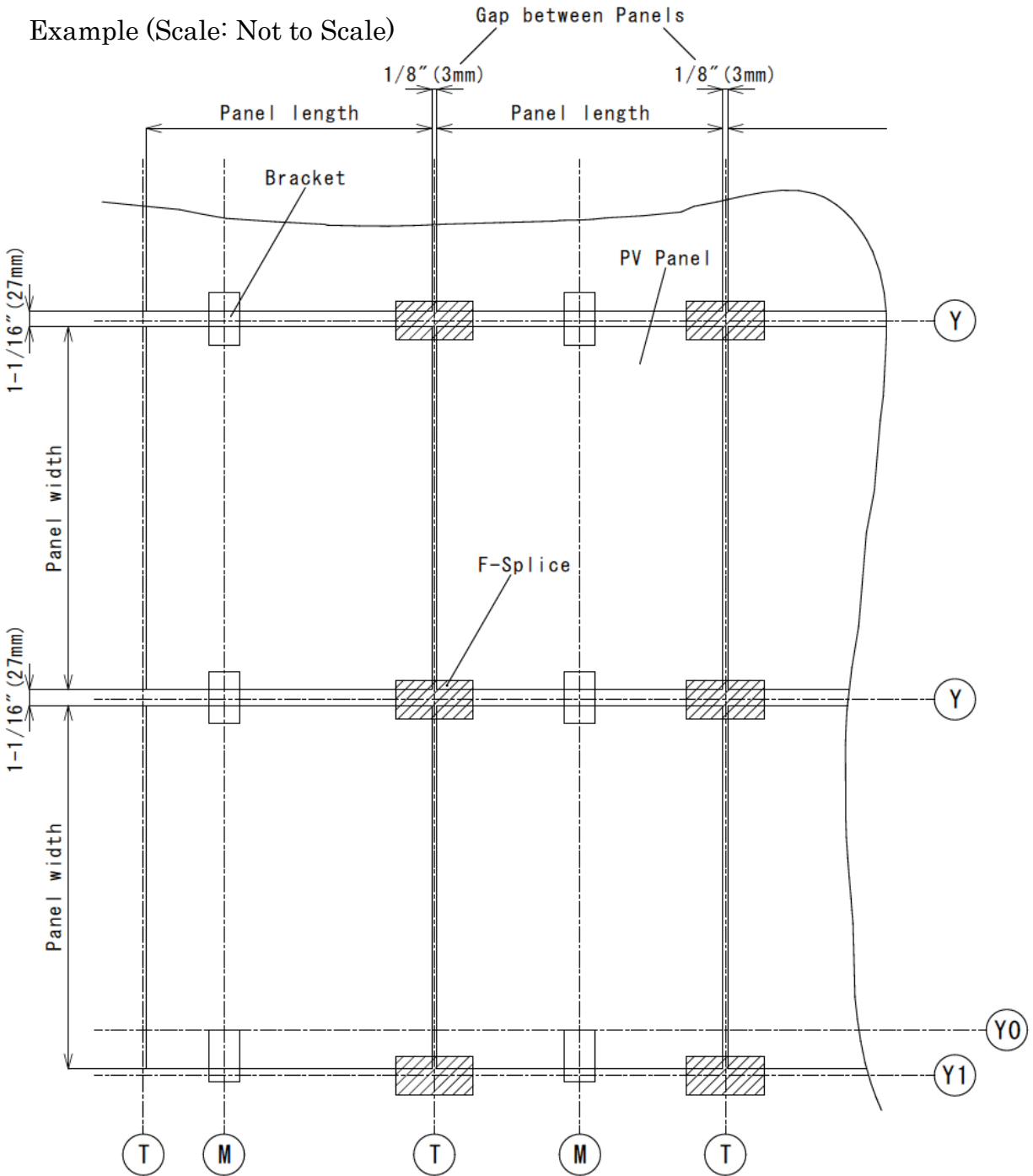

Note: Minimum distance 1/8" (3 mm) between panels.

! Attention

A floating splice must be an approved method and included in the PV module manufacturer installation instructions.

b) Installation on the DECK ③

Example (Scale: Not to Scale)

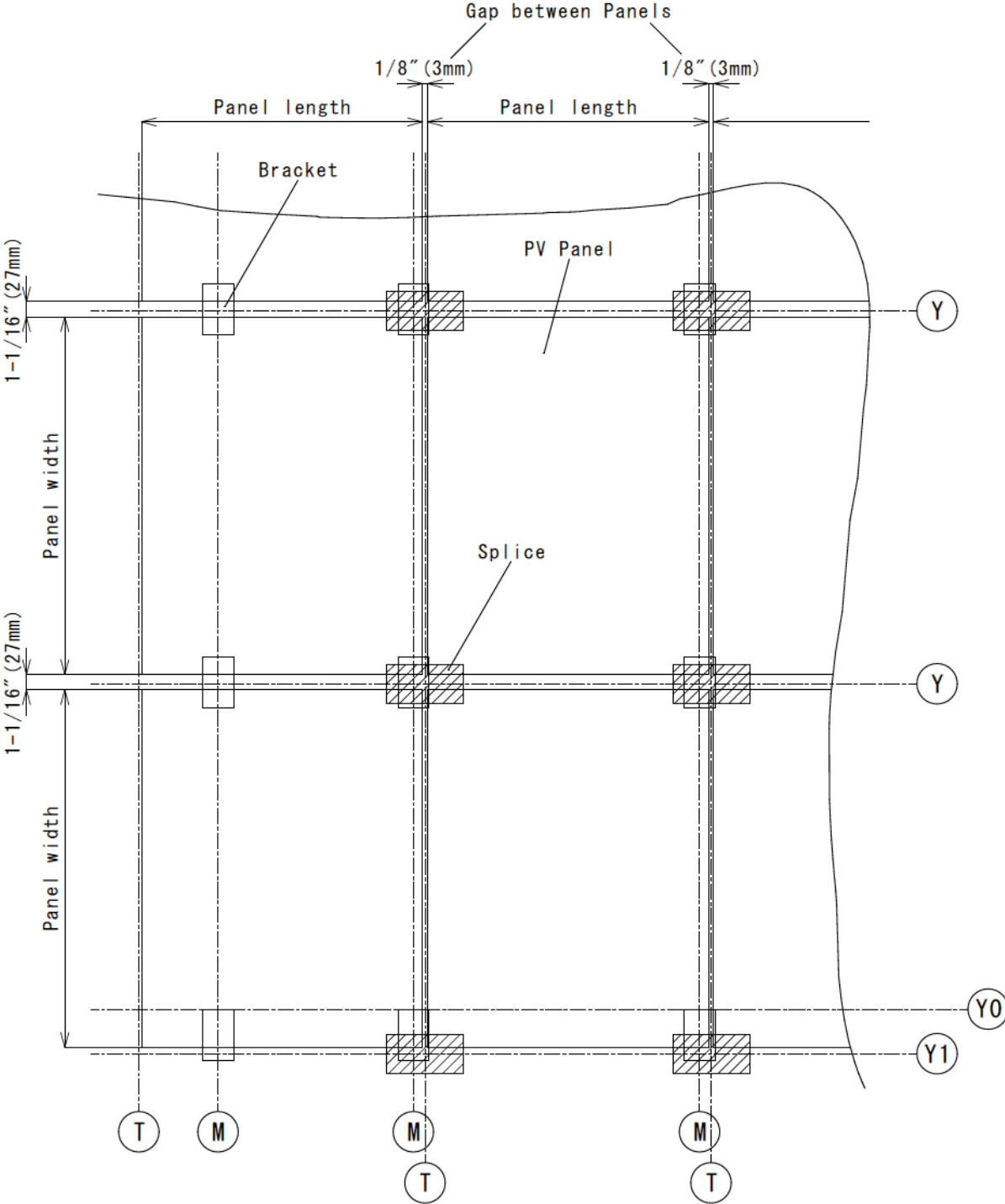

Note: Minimum distance 1/8" (3 mm) between panels.

PART E: Electrical Setup

1. Cable Management

Cable Management of the U-D Bracket (U-D Splice)

- ① Cables and wires can be routed inside the tray under U-D Bracket.

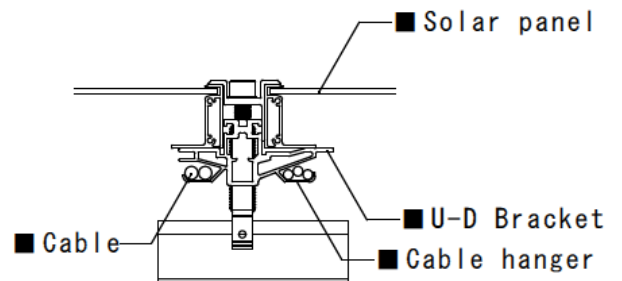
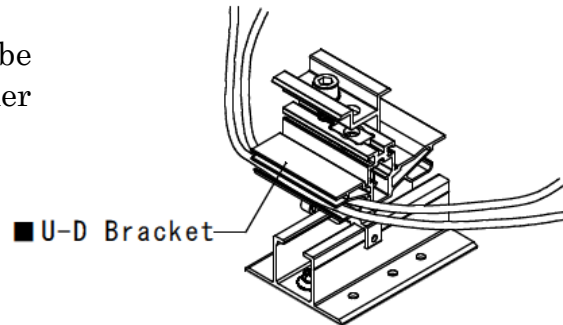

- ② If Cables and wires are loose, use a cable tie through the U-D bracket hole.

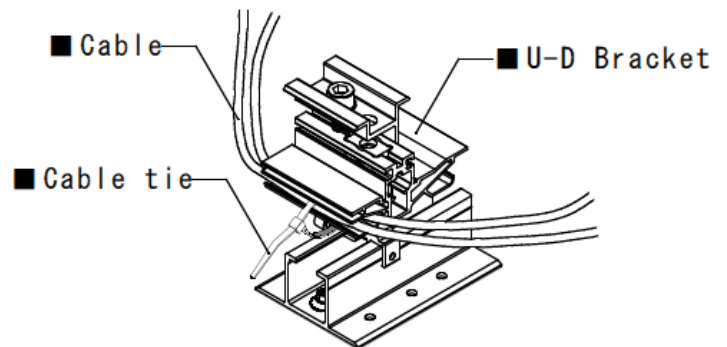
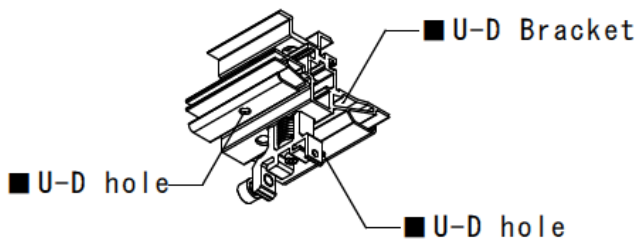

Note : Cable Tray can hold 2 to 3 cables depending on the gauge and insulation.

AWG size	Number of Cables to be hosted
8, 10,12	2
14	3

2. Grounding Setup

All electrical installation and procedures should be conducted by skilled, licensed and bonded electricians. Installer is responsible for and shall provide an appropriate method of direct-to-earth grounding in accordance with the latest edition of the Canadian Electrical Code Part 1, CSA 22.1 Safety Standard for Electrical Installations or the National Building Code, including NEC 250: Grounding and Bonding, and NEC 690: Solar Photovoltaic Systems.

Please refer to your local Building and Electrical Codes.

RT-APEX hardware are classified to UL 2703 and it is to be used with UL 1703 listed PV modules.

We recommend the use of either the Weeb-6.7 or IlSCO SGB-4 Grounding lug with a minimum 10 AWG solid copper grounding conductor. Alternate Grounding lugs shall be installed per PV manufacturers' instructions, using the hardware and/or requirements provided by the PV manufacturer.

Example ①

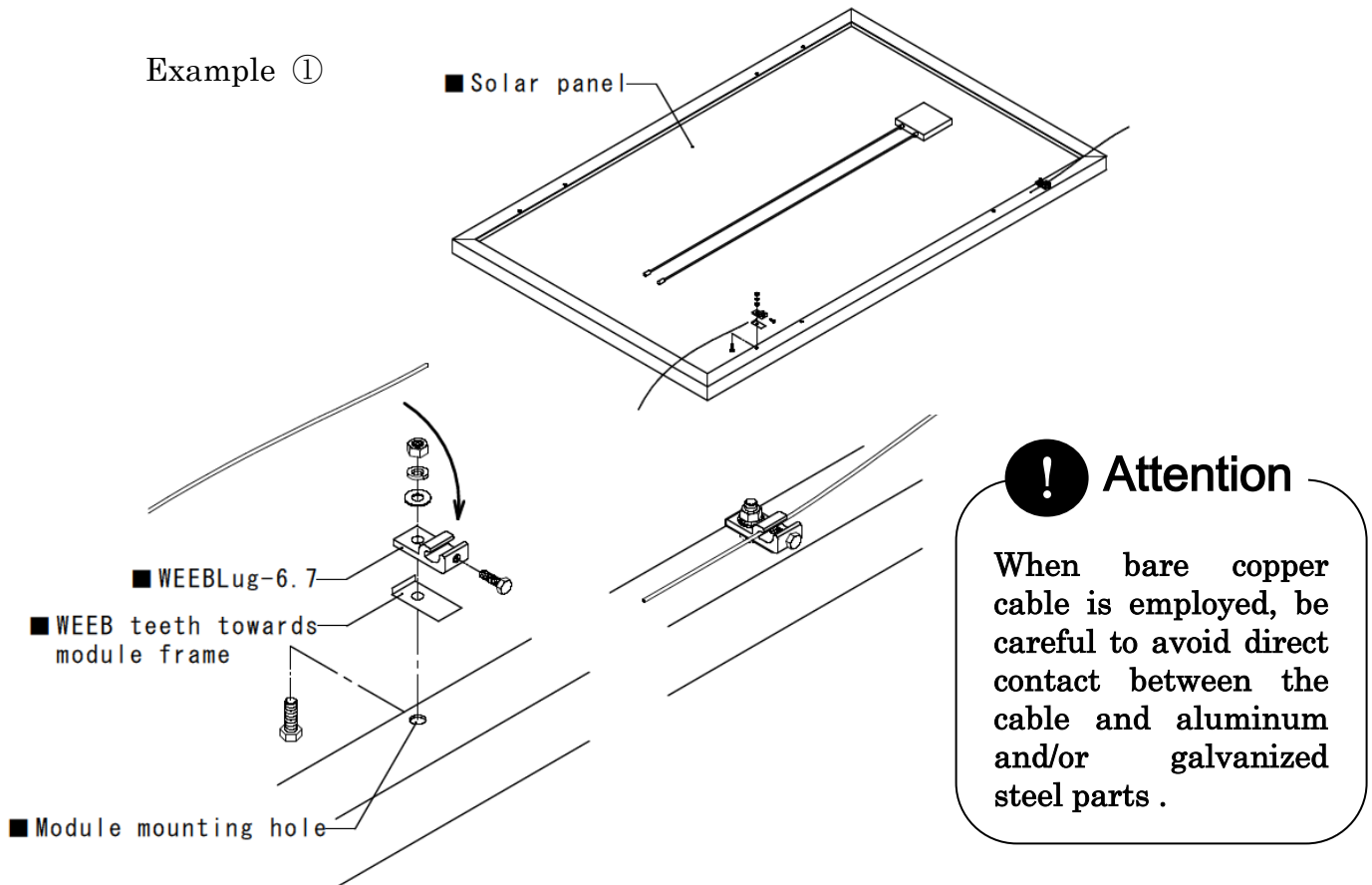

Example ②

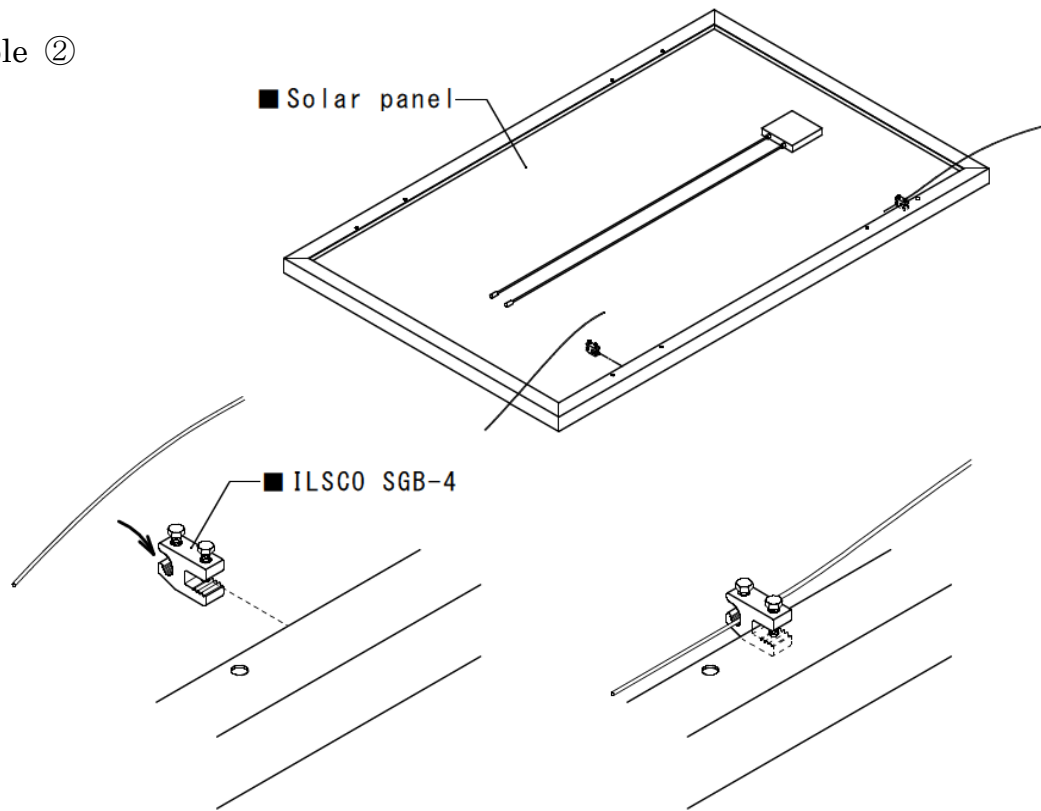

Example ③

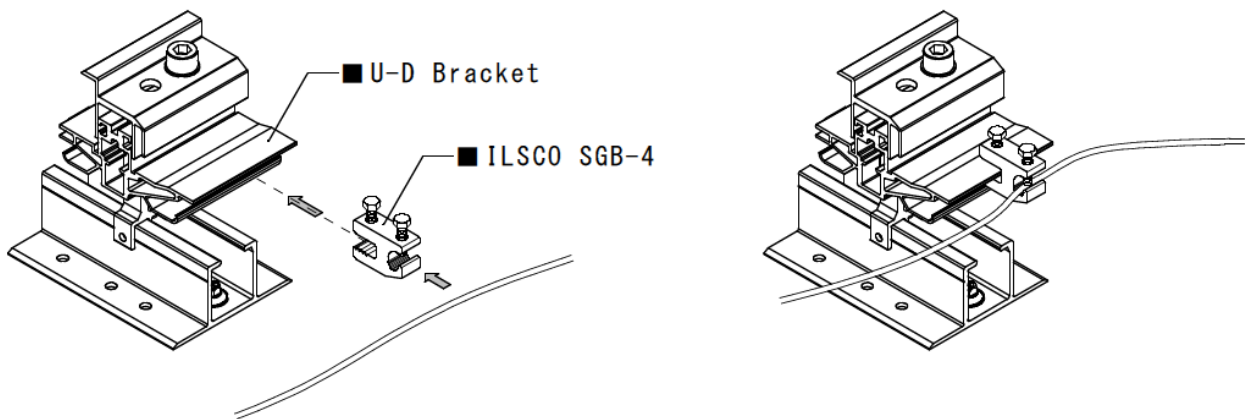

3. Bonding Path Diagrams

A: Bonding Middle Clamp

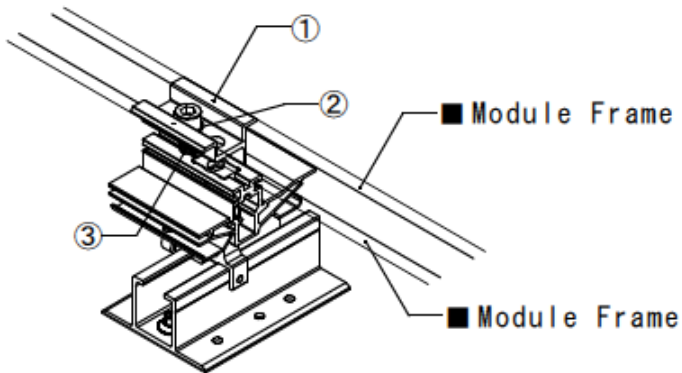

A

- ① The stainless steel bonding teeth integrated in the Middle Clamp pierces the module frame anodization to bond module to module through the clamp. (Bonding path between PV panels)
- ② The toothed washer bonds the aluminum Middle Clamp to the stainless steel head cap screw, removing the clamp anodization.
- ③ The head cap screw thread creates the bonding path to the U-D Bracket.

B: Bonding End Clamp

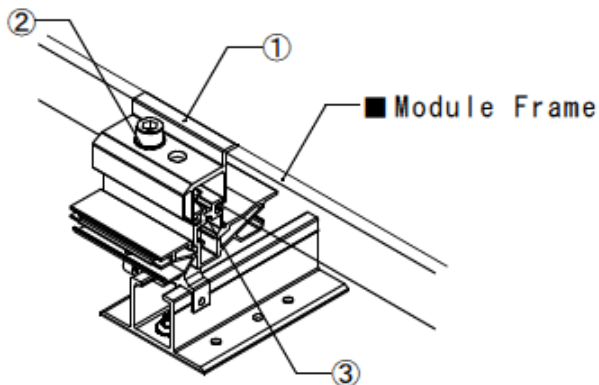

B

- ① The stainless steel bonding teeth integrated in the end clamp pierces the module frame anodization to bond module to clamp.
- ② The toothed washer bonds the aluminum end clamp to the stainless steel head cap screw, removing the clamp anodization.
- ③ The head cap screw thread creates the bonding path to the U-D Bracket.

C: Bonding Splice (Middle and End)

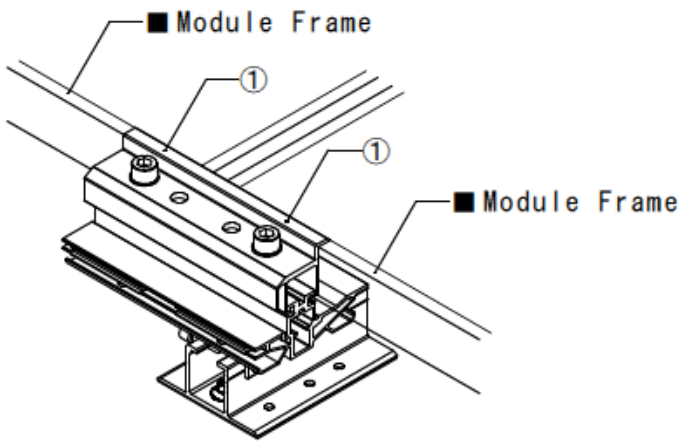

- ① The stainless steel bonding teeth integrated in the splice clamp pierces the module frame anodization to bond module to module through the clamp. (Bonding path between PV panels installed next to each other)

C

C': Bonding Floating Splice (Middle and End)

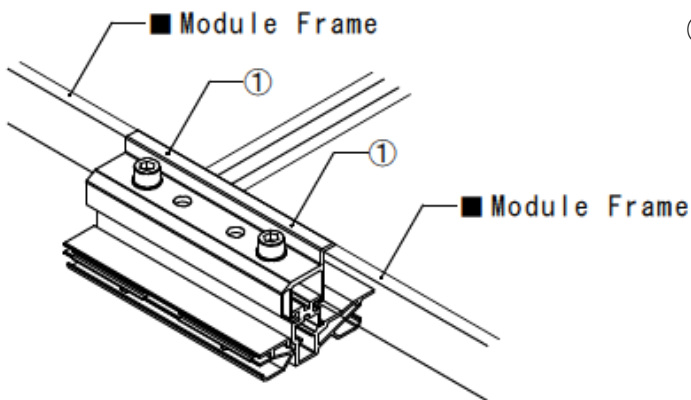

- ① The stainless steel bonding teeth integrated in the splice clamp pierces the module frame anodization to bond module to module through the clamp. (Bonding path between PV panels installed next to each other)

C'

D: DynoBond

① DynoBond 8"

Can be an option for PV frames not listed.

Limited to a 20A Maximum Fuse Rating. (Follow DynoBond installation instructions and certification to the PV Module being installed)

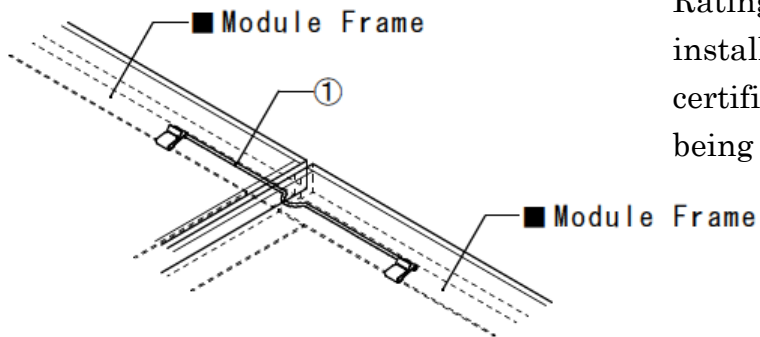

D

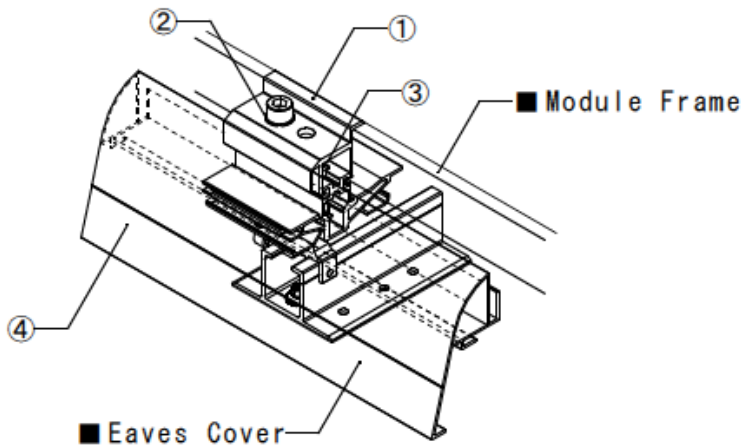
E: Bonding Eaves Cover**E**

- ① The stainless steel bonding teeth integrated in the end clamp pierces module frame anodization to bond module to clamp.
- ② The toothed washer bonds the aluminum end clamp to the stainless steel head cap screw, removing the clamp anodization.
- ③ The head cap screw thread creates the bonding path to the U-D Bracket.
- ④ The U-D bonding clip of the U-D Bracket holds the eaves cover in to the channel, and its teeth and surface creates a bonding path.

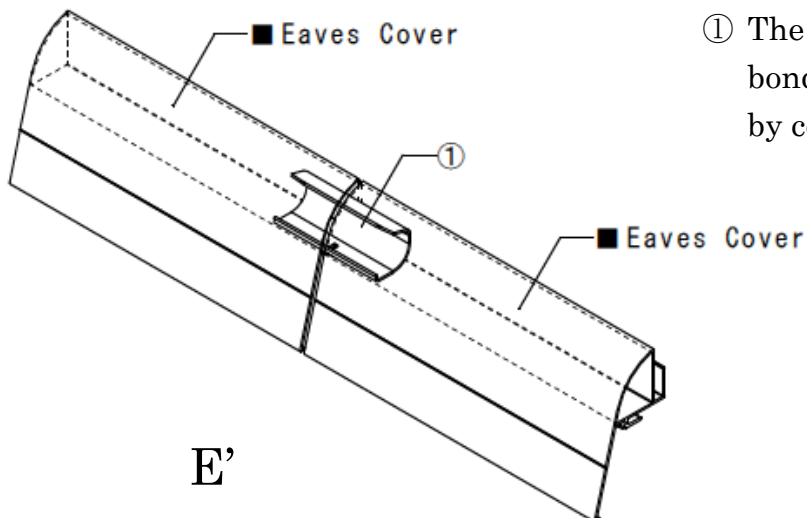
E': Skirt Bonding Splice**E'**

- ① The eaves cover joint creates a bonding path between the eaves cover by contact of the surfaces.

F: WEEB Lug or ILSCO Lug

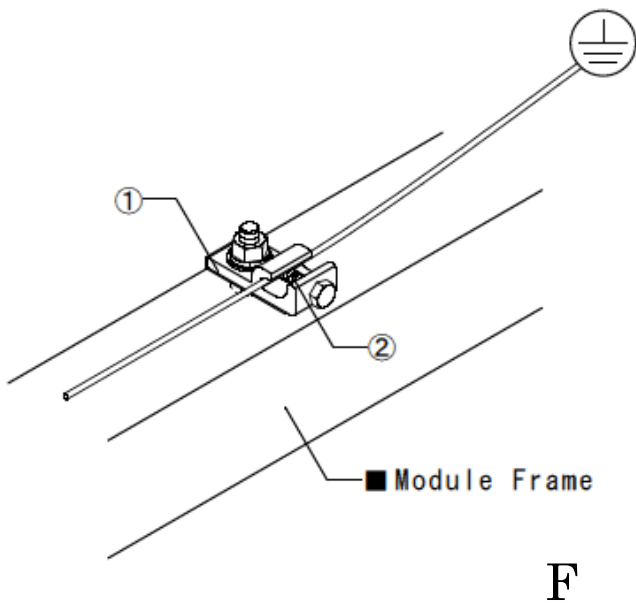

- ① WEEB washer dimples or ILSCO Lug teeth pierces the anodized module frame to bond the frame to the lug.
- ② Solid copper wire connected to the lug is routed to provide final system ground connection.

F

G: ILSCO Lug attached to the U-D Bracket

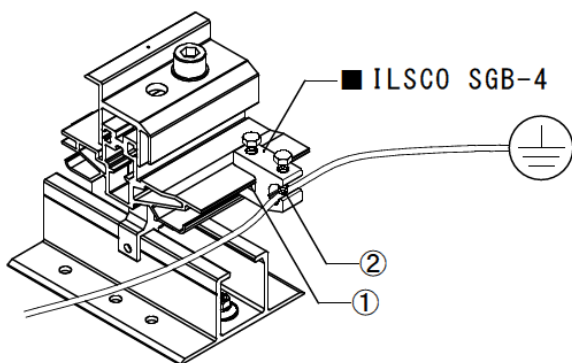

- ① The ILSCO Lug teeth creates a bonding path between U-D Bracket and grounding wire.
- ② Solid copper wire connected to the lug is routed to provide the final system ground connection.

G

Example of Bonding Path ①

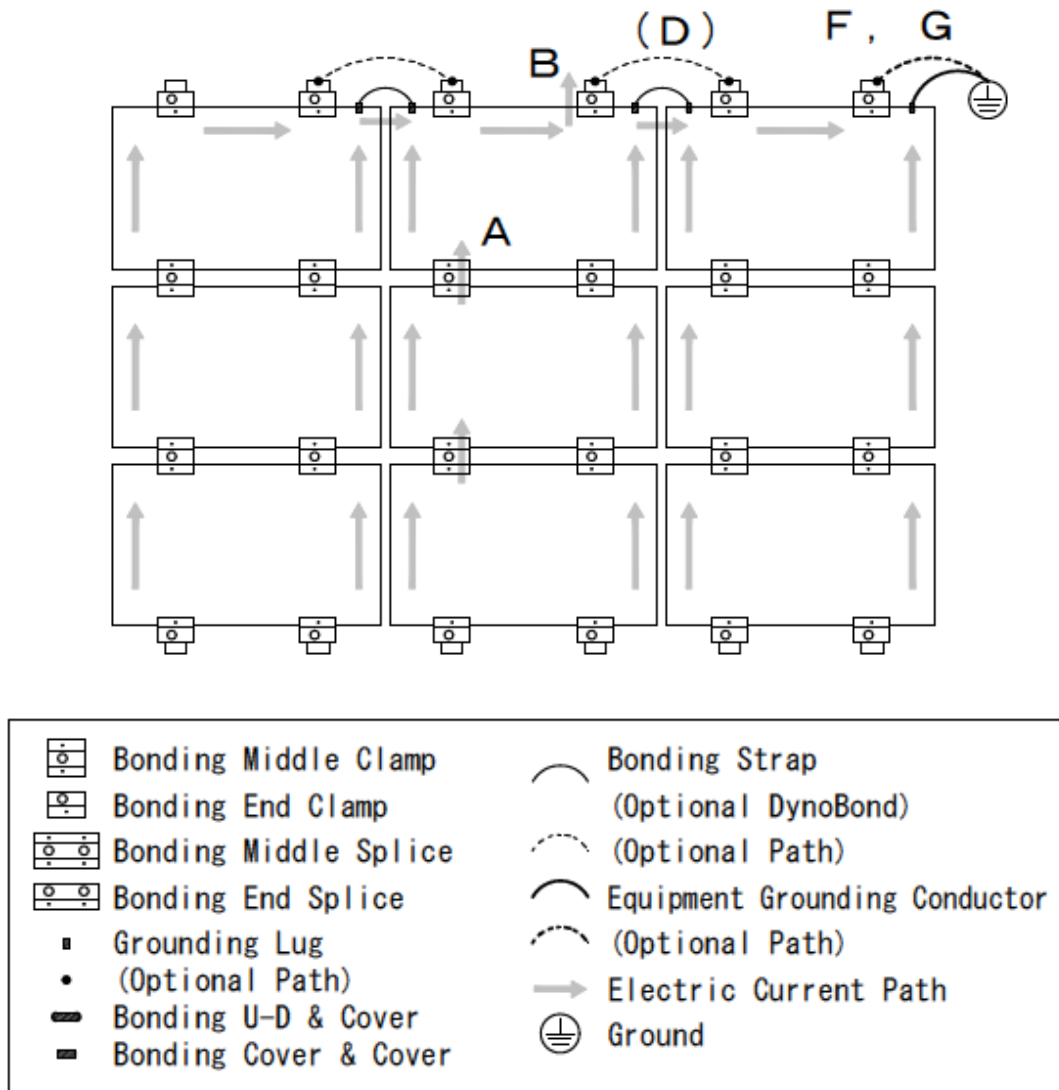

In order to properly ground the PV modules and the brackets to the equipment ground, a grounding lug or lay-in lug must be attached to the PV module or the RT-APEX's U-D Bracket at the end of each row. When the skirt is bonding the adjacent rows, there is no need to attach the grounding lug at the end of each row (see examples 2 and 3) Notice that the PV frame is part of the bonding path.

Note: Grounding, Bonding lugs and Straps are not provided by Roof Tech Inc.
(See Page 10)

Example of Bonding Path ②
 (Bonding path through Skirt and Skirt Splice)

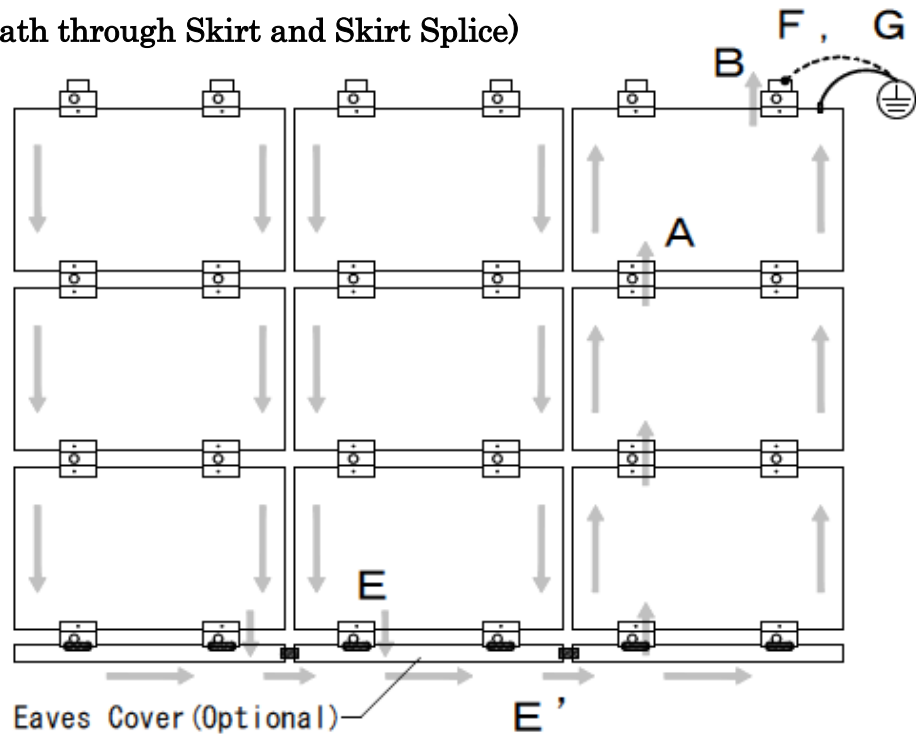

Example of Bonding Path ③
 (Bonding path through Skirt)

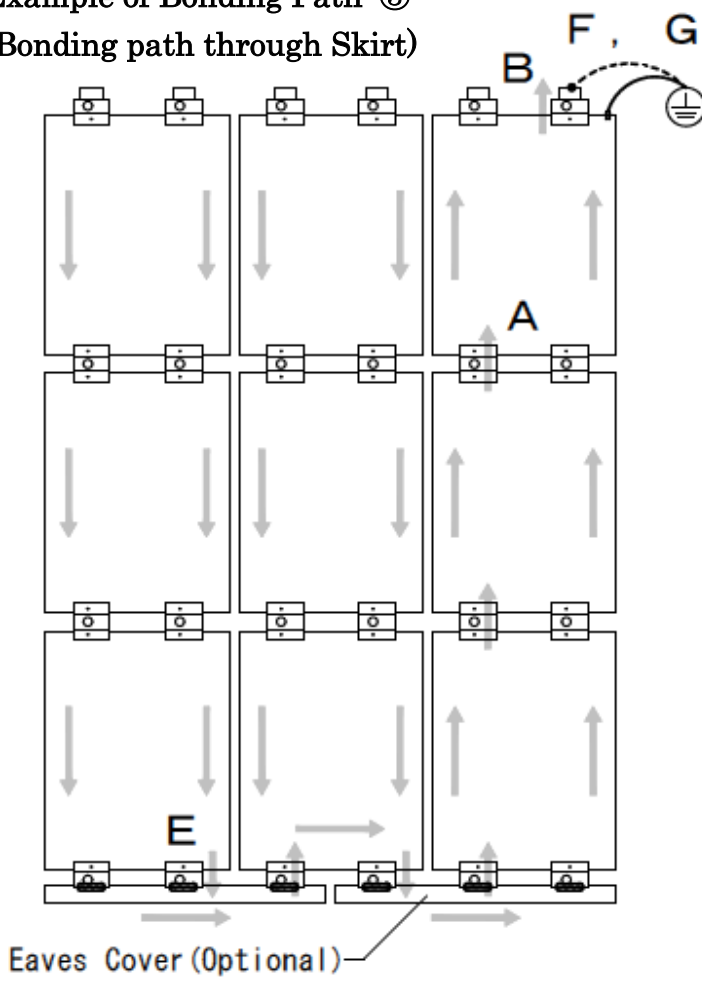

	Bonding Middle Clamp
	Bonding End Clamp
	Bonding Middle Splice
	Bonding End Splice
	Grounding Lug
	(Optional Path)
	Bonding U-D & Cover
	Bonding Cover & Cover
	Bonding Strap
	(Optional DynoBond)
	(Optional Path)
	Equipment Grounding Conductor
	(Optional Path)
	Electric Current Path
	Ground

Example of Bonding Path ④ (Bonding path through Splice Bracket)

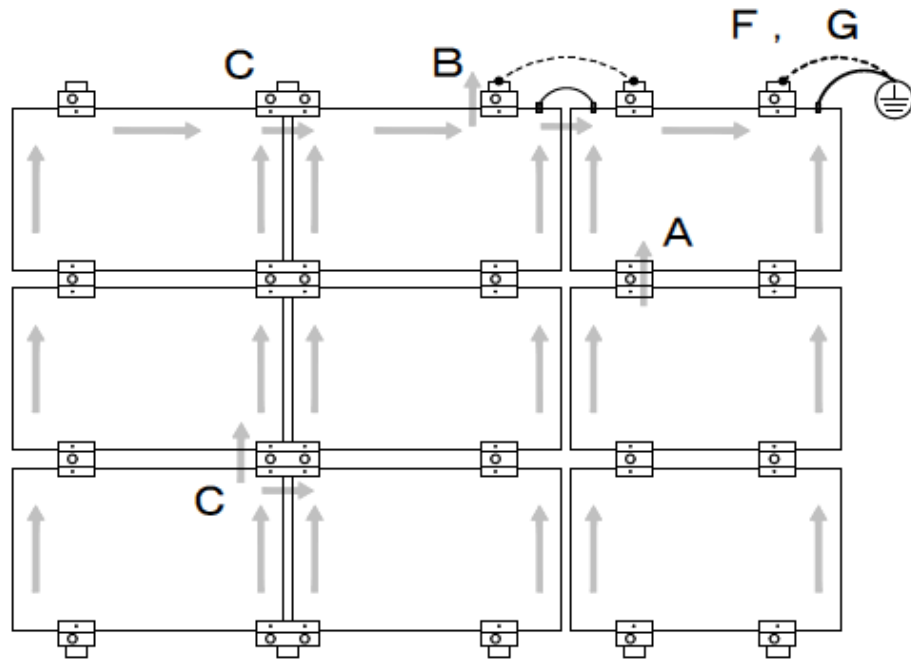

Example of Bonding Path ⑤ (Bonding path through Floating Splice Bracket)

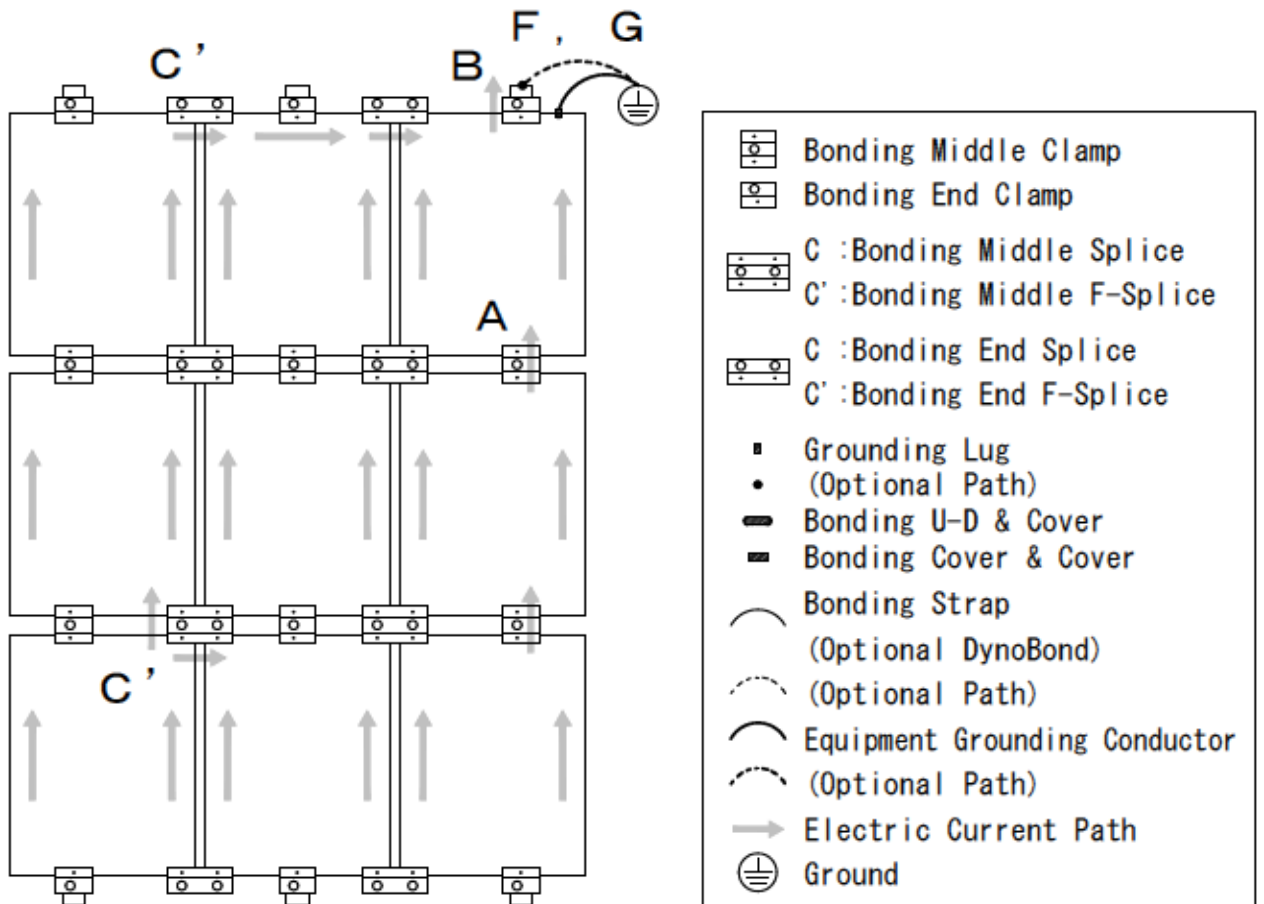

Installation on a Metal Roofing

1. Requirement

- Applicable to maximum 20 gage metal decking.
- The roof should have sheathing (deck) board and the metal roofing should be flat and flush against the sheathing board at least 4" (102mm) by 5-1/2" (140mm) area at the bracket mounting location. The Roof Tech P.E. Letter are created for a minimum 7/16" OSB with 2" x 4" rafters 24 in o.c.

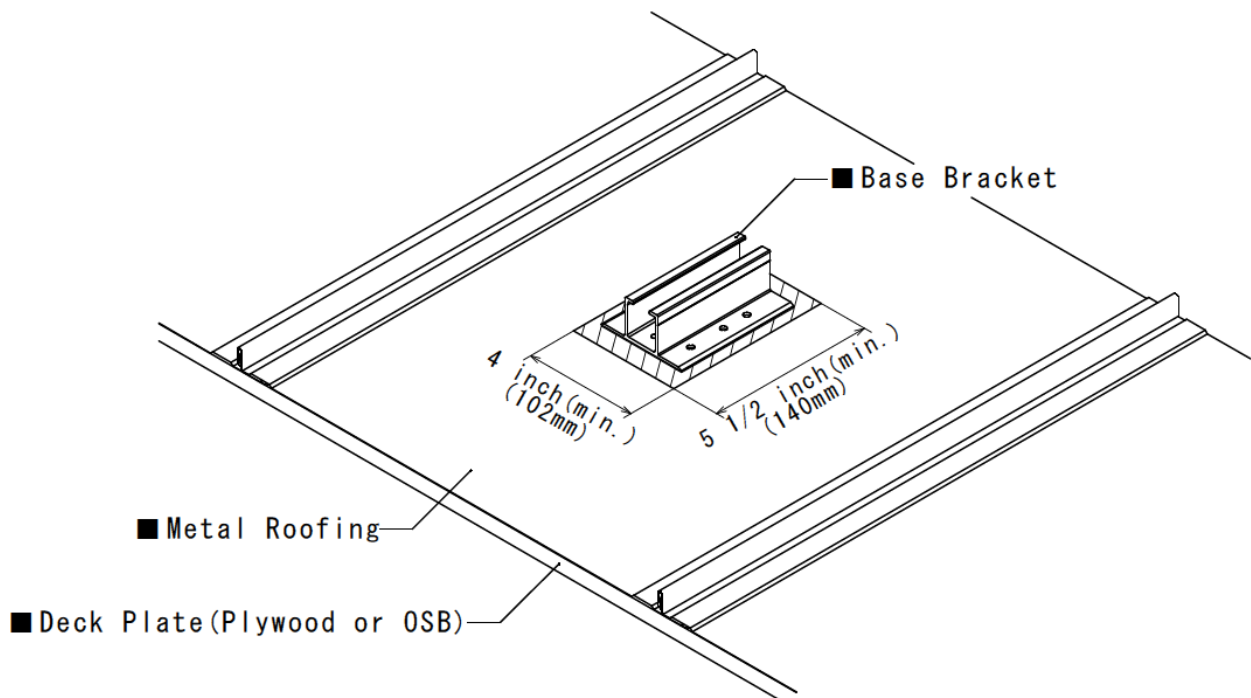

2. Marking on the Roof

(1) Layout (Rafter)

- ① Make at $\pm 45\text{mm}$ from the intersection of the R line and Y line on the R line.
(See illustrations.)

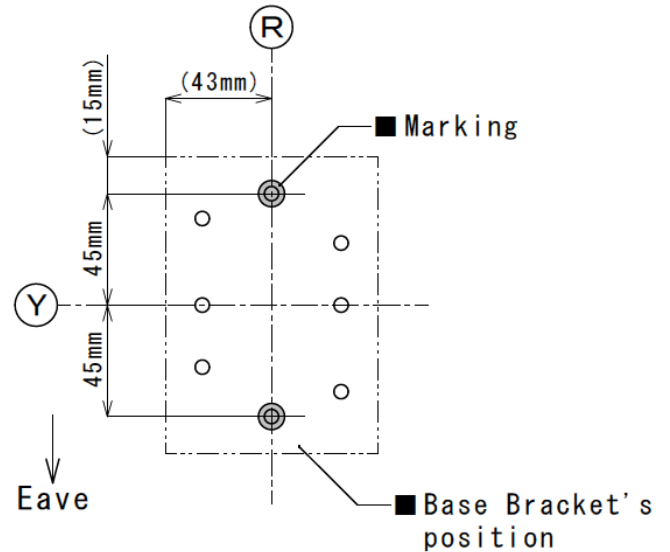

(2) Layout (Deck)

- ① Make at $+45\text{mm}$ from the intersection of the M line and Y line on the M line.
- ② Make at $\pm 28\text{mm}$ from the M line.
- ③ Then make at $\pm 25\text{mm}$, $\pm 35\text{mm}$ from the Y line.
(See illustrations.)

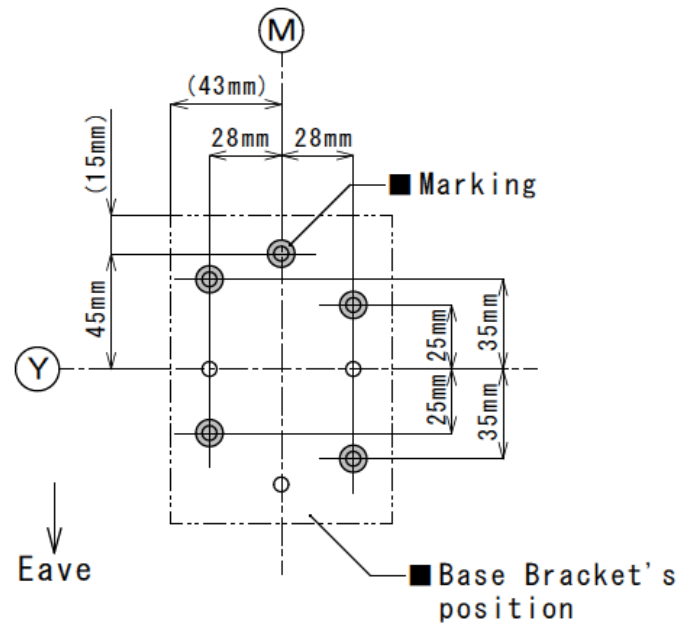

! Attention

Note; Marking spot is not symmetric when base is installed on deck. You may want to have an extra Base Bracket to assist in marking to a metal roof. (Create a Base Bracket JIG by removing the RT Butyl from it.)

The use of a center punch is an alternative as a starter to cut a small pilot hole as long as there is no air gap underneath it.

3. Bracket Installation

- ① Drill the roofing metal sheet with a $\phi 1/8"$ ($\phi 3$ mm) drill bit at the markings.
- ② Clean up the drilled chips and fill the drilled hole with roof sealant.

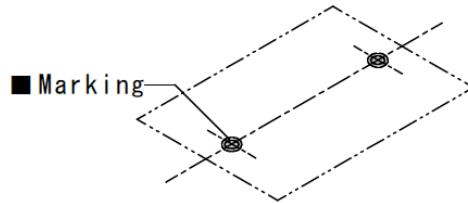
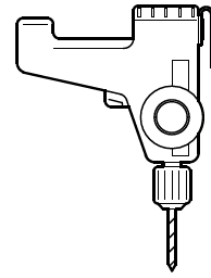

! Attention

Be careful to minimize the intrusion of the drill bit into the roof sheathing. Drill only on the metal roof.

■ Roof Sealant

■ Drilled Hole

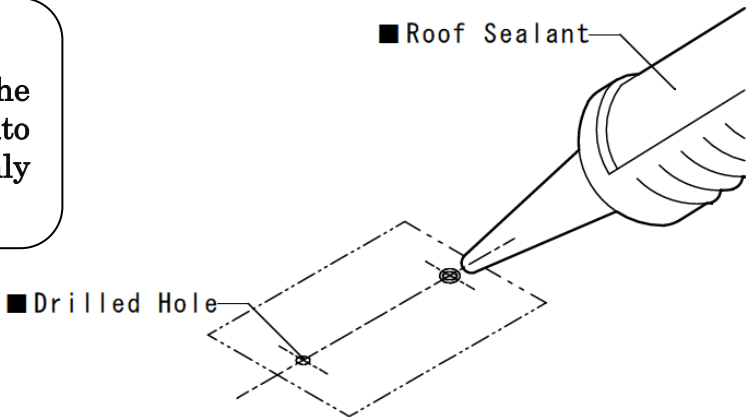

- ③ Peel off the release paper from the RT butyl tape.

■ Protective Paper

■ RT Butyl Tape

■ Base Bracket

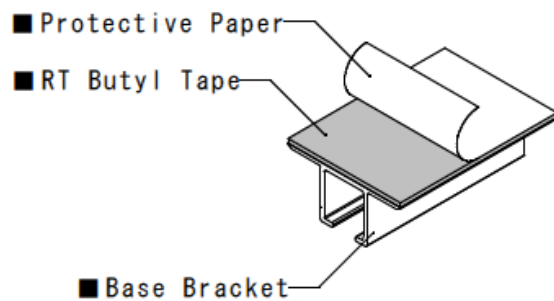

! Attention

Do not leave any protective paper on the surface of the RT butyl tape, it can cause an improper seal and may allow water intrusion under the bracket.

④ Installing the bracket.

Place the brackets at the specified position with RT butyl tape and make sure the RT butyl attaches well to the roofing surface.

Set the bracket with 2 ea. screws (for RAFTER), or 5 ea. (for Roof DECK), 5.0×60 mm stainless wood screw using 8 mm socket.

After completing process, make sure the brackets are securely fixed.

! Attention

•Note: "R" logo on top right of the base should always be on the ridge side when installing.

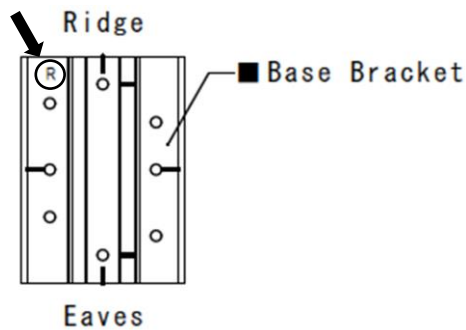

Rafter Install

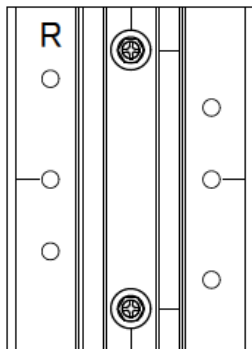

The screw location for
Rafter Installation

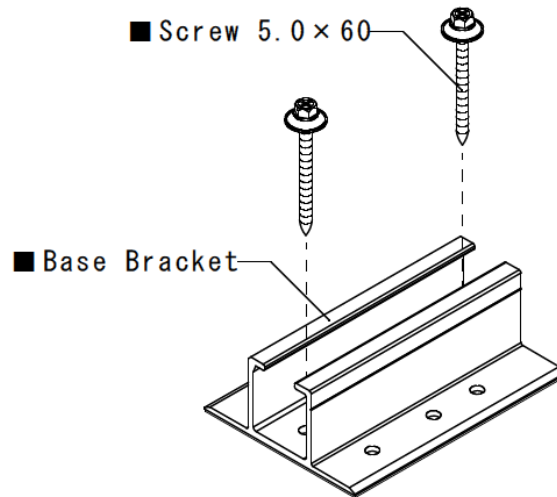

Deck Install

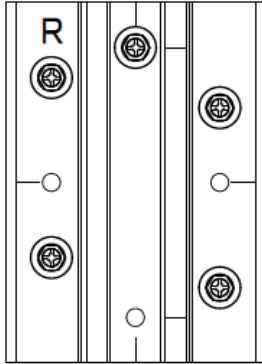

The screw location for
Deck Installation

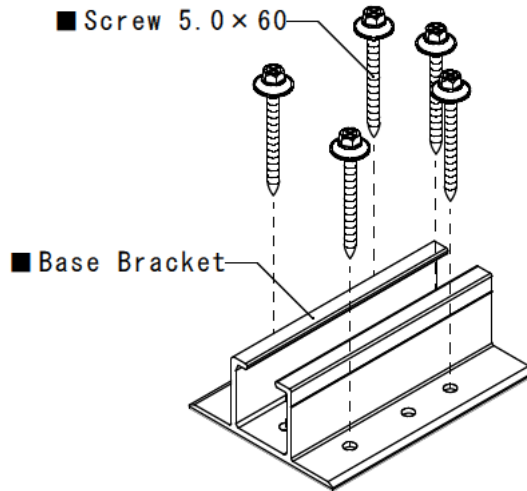

! Attention

Note: Proper torque values for the 5.0×60 mm screw will vary depending on the rafter and/or deck characteristics; hardness, age, and moisture of the wood. Tighten until the washer just stop rotating easily.

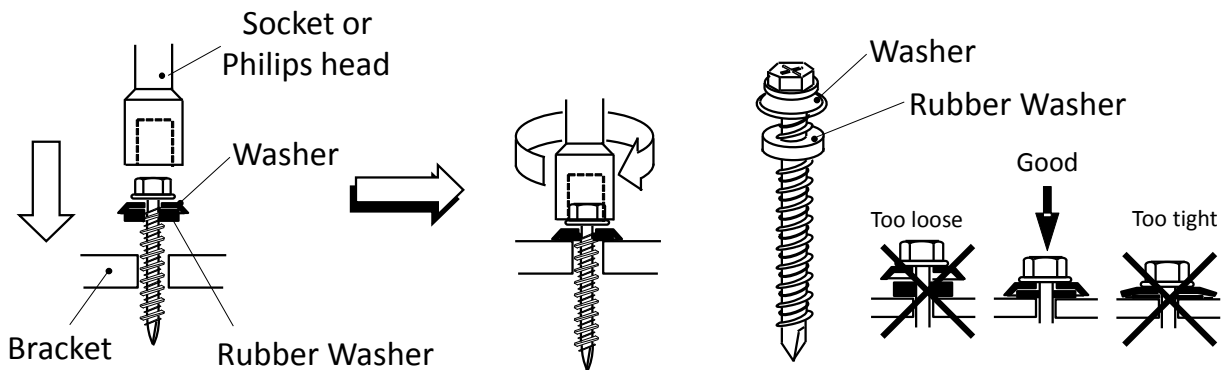

When tightening the screws please tighten all screws equally and avoid using an impact driver as it can over torque the screws or even snap off the head.

- ⑦ [Optional Sealant Layer] Apply roof sealant around the brackets, the top and each side edge of the brackets. Cover the exposed RT butyl tape with roof sealant. Do not seal the bottom of the brackets.

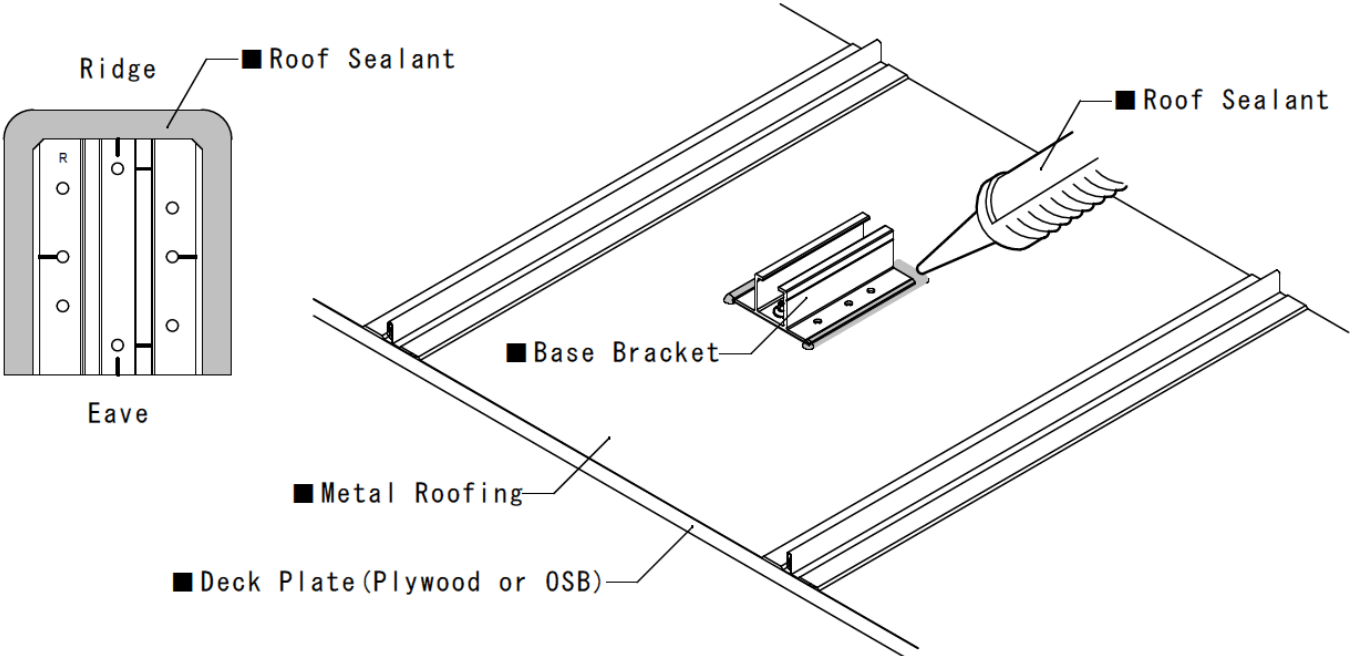

Installation on a Classic rib metal roofing

1. Requirement

- The Roof Tech P.E. Letters are created for a minimum 7/16" OSB with 2x4" rafters 24 in o.c.

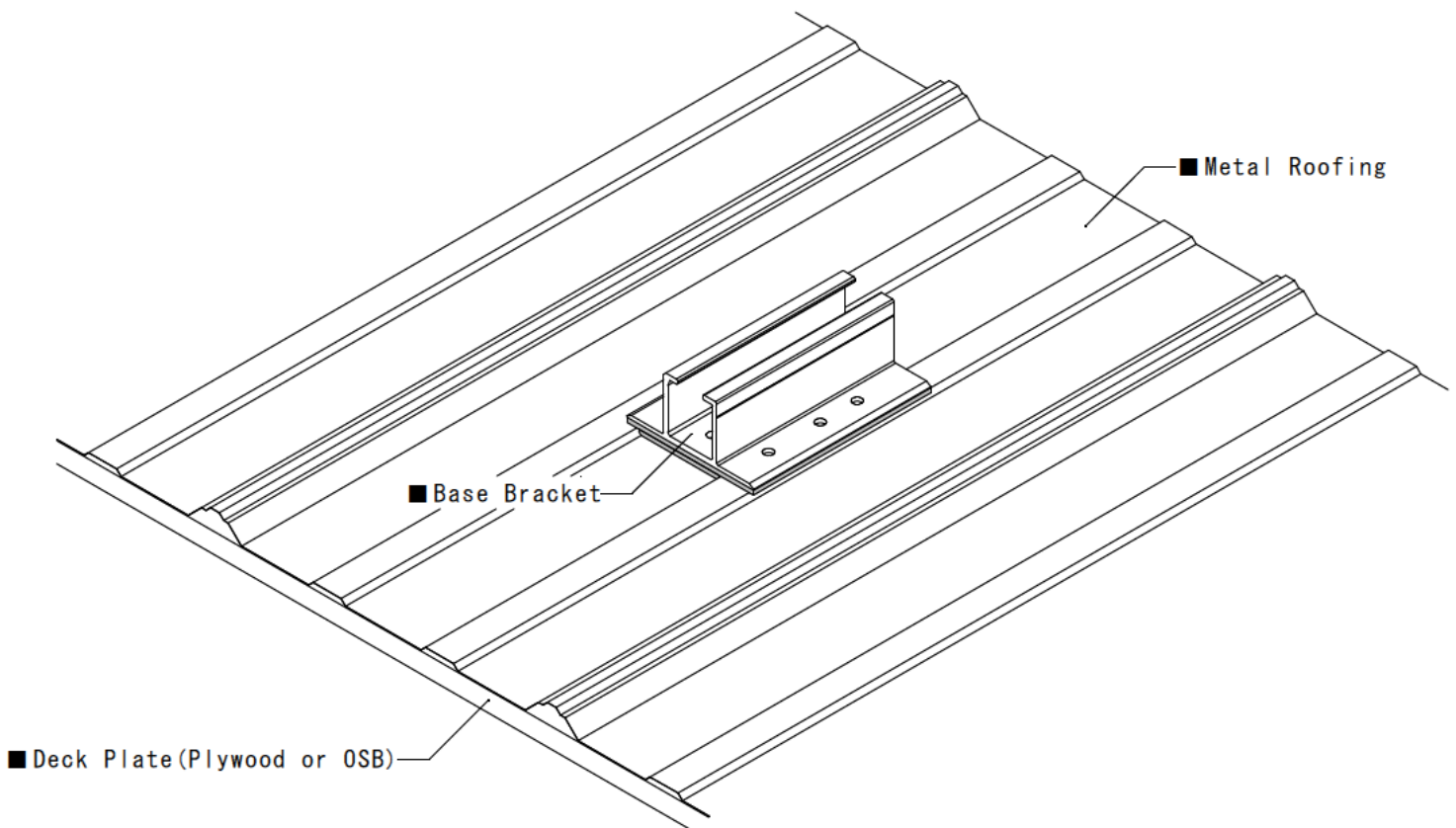

2. Marking on the Roof

(1) Layout

- ① The Base bracket must be mounted on the flat surface. Please make sure the location is not on slope surface of metal ribs. Screw must be fixed to the flat surface. Also, its center must clear 5mm from the edges (Please refer to the 3 pictures on the right.)

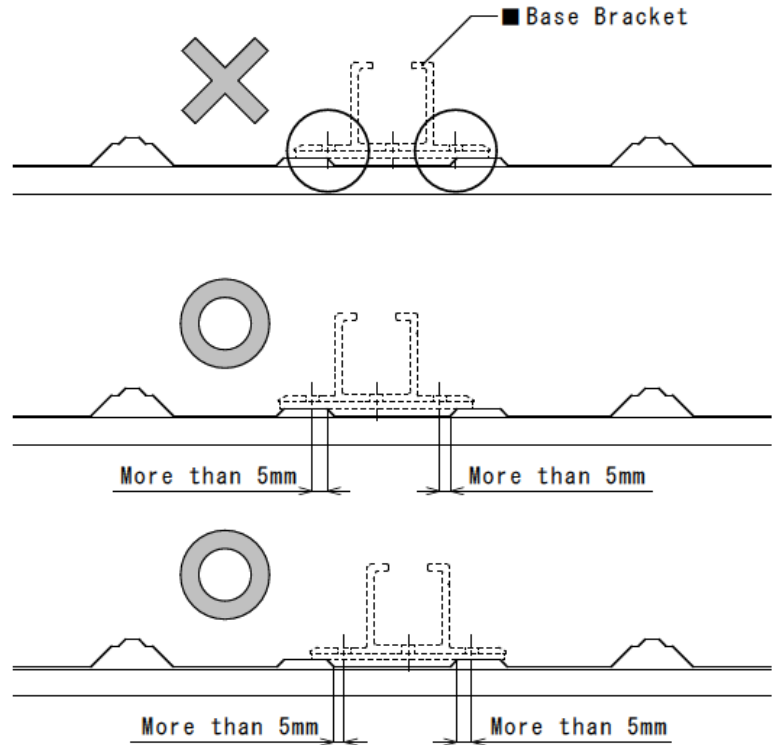

- ② Make at +45mm from the intersection of the M line and Y line on the M line.
- ③ Make at $\pm 28\text{mm}$ from the M line.
- ④ Then make at $\pm 25\text{mm}$, $\pm 35\text{mm}$ from the Y line.
(See illustrations.)

[Fastening to the Deck]

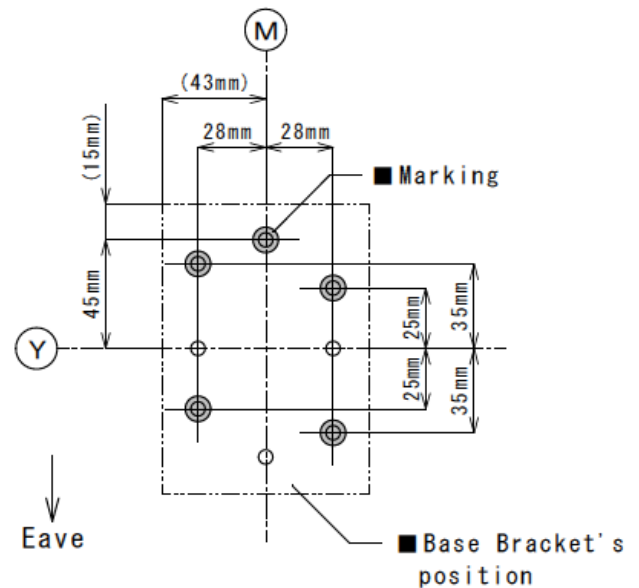

! Attention

Note; Marking spot is not symmetric when base is installed on deck. You may want to have an extra Base Bracket to assist in marking to a metal roof. (Create a Base Bracket JIG by removing the RT Butyl from it.)

- (2) Check the height of metal rib.
5mm Maximum height H

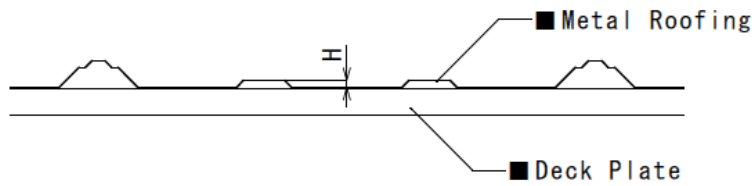

- ① Use Center punch to make a pilot hole. You can mark on roof or use base's screw hole directly from top of the base. Must be no gap underneath for the use of a center punch.

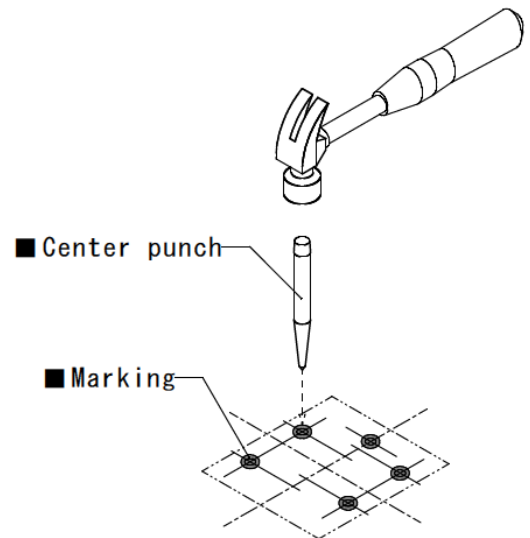

3. Bracket Installation

- ① Please add a butyl pad (RT - Butyl Spacer) on the surface between the ridges.

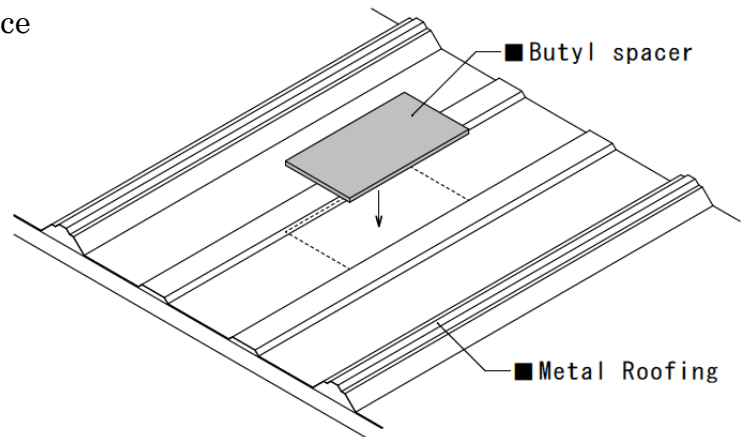
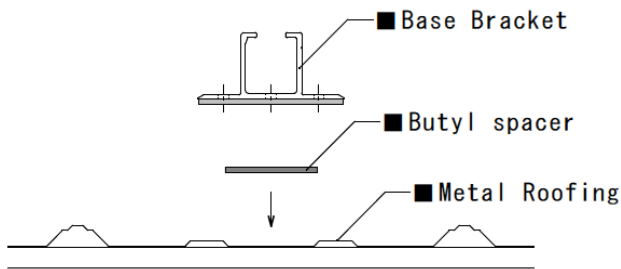

- ② Peel off the protective paper from the RT butyl tape.

! Attention

Do not leave any protective paper on the surface of the RT butyl tape, it can cause an improper seal and may allow water intrusion under the bracket.

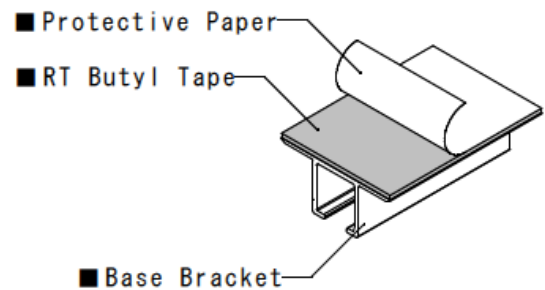

- ③ Place the brackets at the specified location and make sure the RT butyl attaches well to the roofing surface.

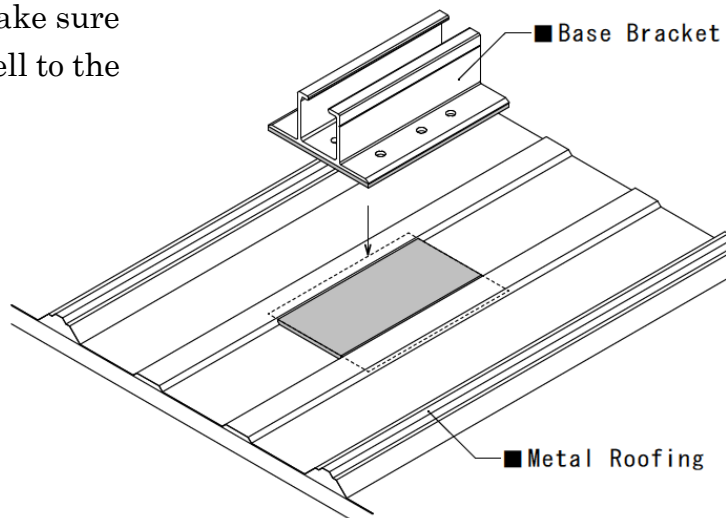

- ④ Set the bracket with 5 ea. (for Roof DECK), of M5.0 × 60 mm stainless wood screw using 8 mm hex socket. After completing process, make sure the brackets are securely fixed.

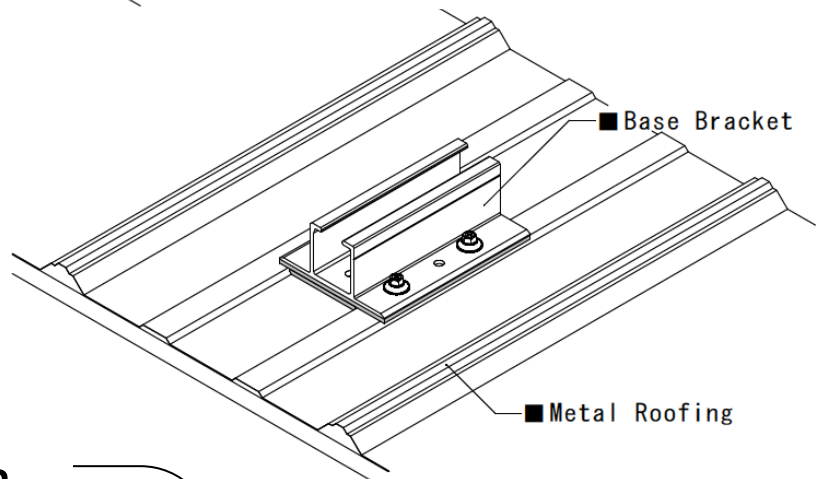
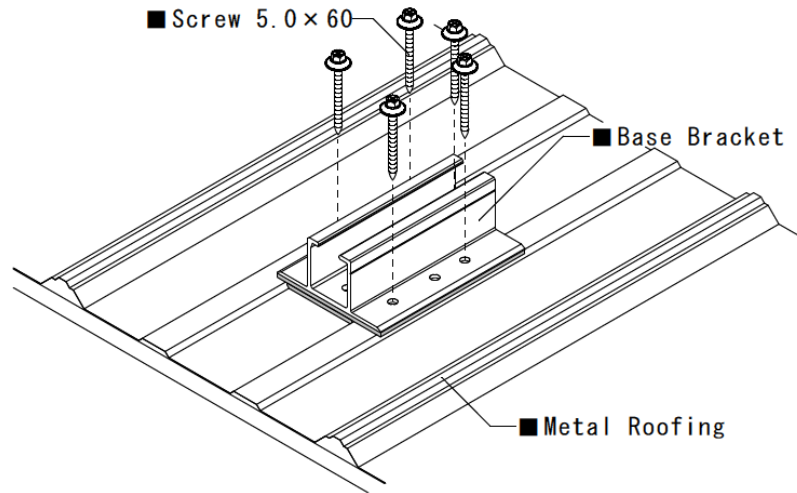

Attention

When the base is installed on the deck, 5 screws must be used. The screws are fixed into the side 4 holes and 1 ridge side hole.

Note; Each base is shipped with 2 mounting screws. The installer must purchase additional screws when mounting it to the roof deck.

- ⑤ Apply roof sealant on the ridge side of the brackets to form a slope and triangle. Optional is the sealant to each side of brackets. Do not apply sealant to the bottom of the brackets.

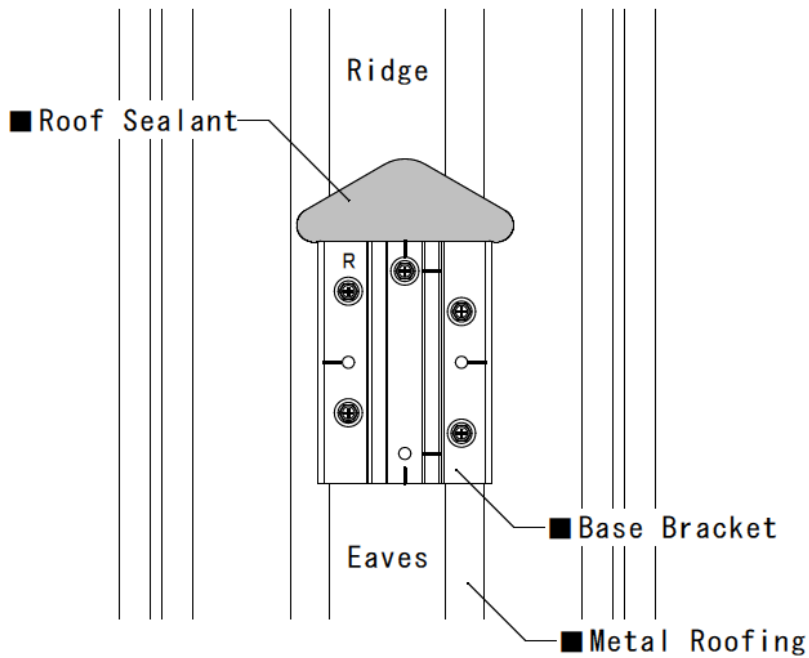
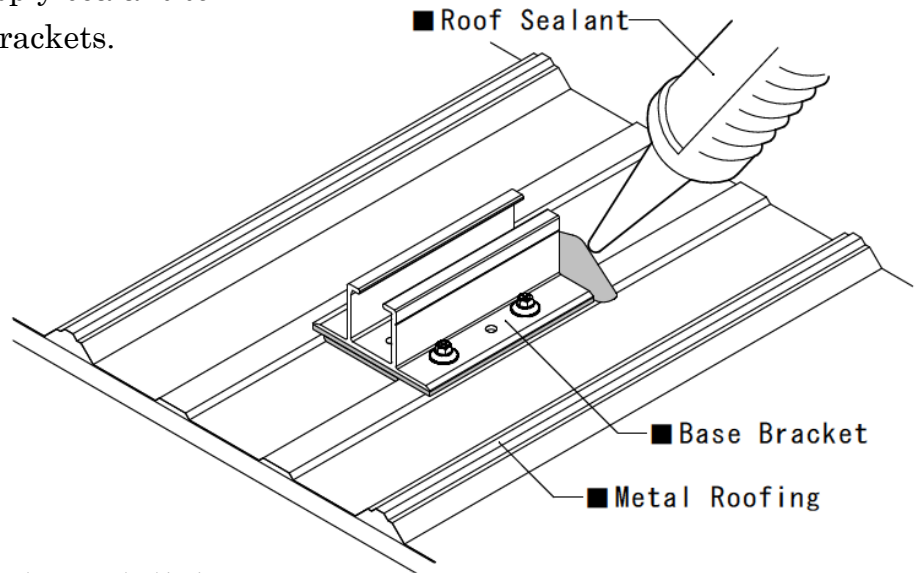

Installation on a Composite Slate

1. Requirement

- Composite Slate, compatible with RT Butyl

2. Marking on the Roof

(1) Layout

- ① Make at +45mm from the intersection of the M line and Y line on the M line.
- ② Make at $\pm 28\text{mm}$ from the M line.
- ③ Then make at $\pm 25\text{mm}$, $\pm 35\text{mm}$ from the Y line.
(See illustrations.)
- ④ If the Base Bracket is located at the gap of the roof surface or within 50mm, the gap has to be filled with sealant or butyl tape as seen in the exhibit to the right.

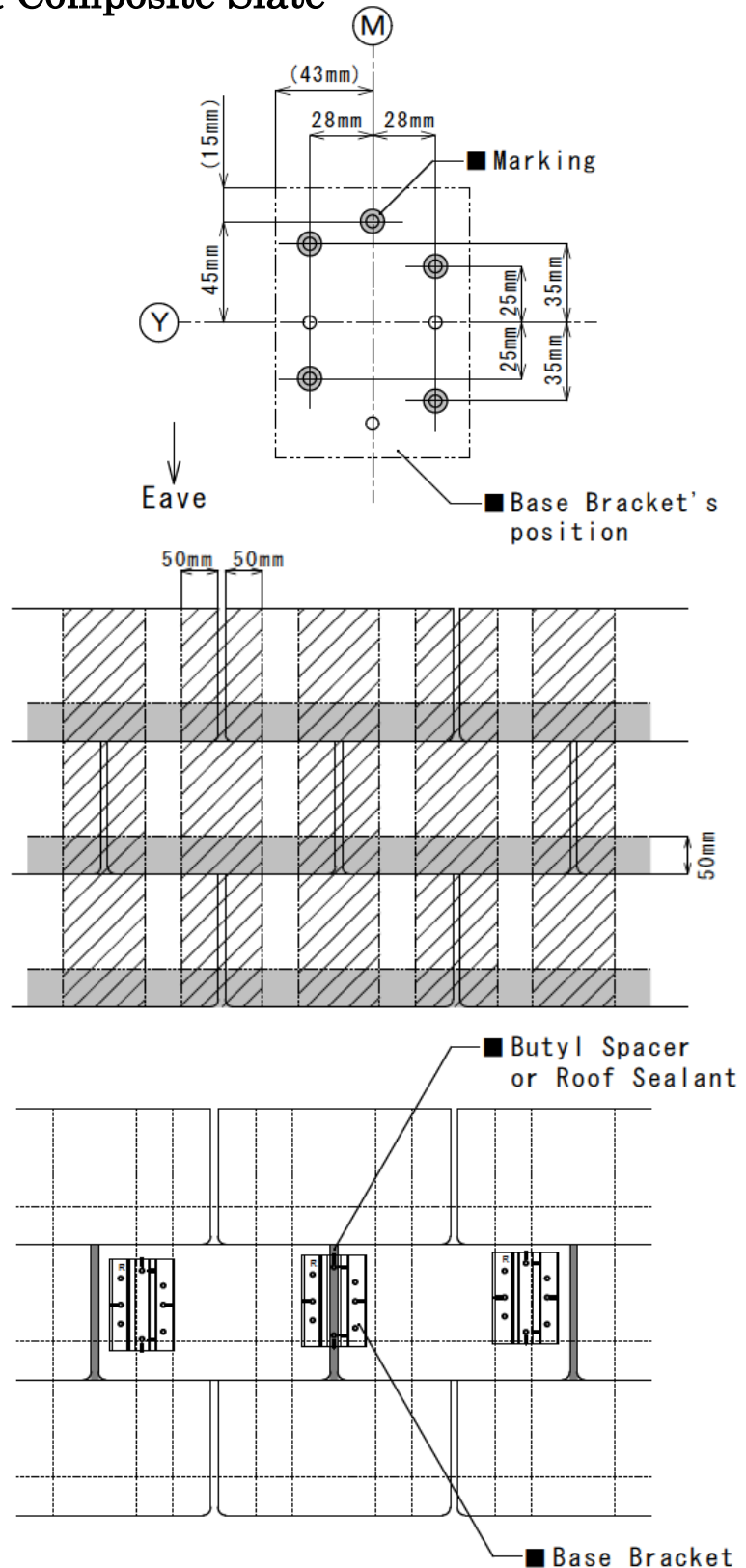

3. Bracket Installation

- ① Drill a pilot hole to fill with sealant with a ϕ 1/4 inch (ϕ 6.5 mm) drill bit at the markings.

Note : It is easier to manage drill depth by using any stopper on the drill bit. Please make sure to use stopper to drill through the layer of roofing material only. Do not to drill all the way to the wood deck or underlayment.

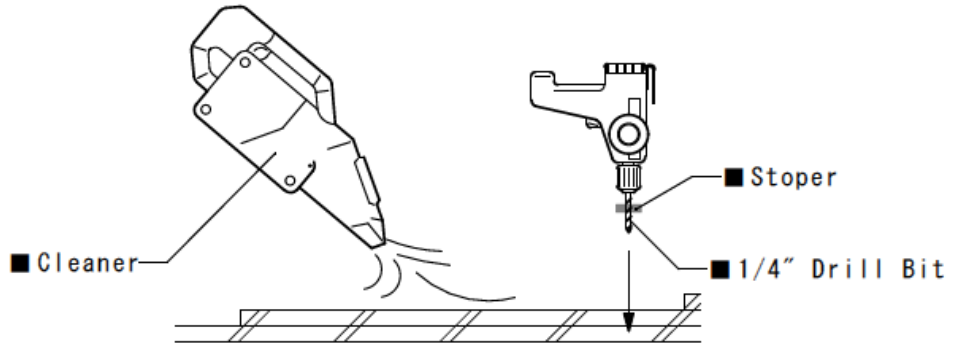

! Attention
You must avoid drilling into the wood underneath it.

- ② Fill the cavity with a sealant listed in our Installation Manual. The sealant must be flush with the slate surface.

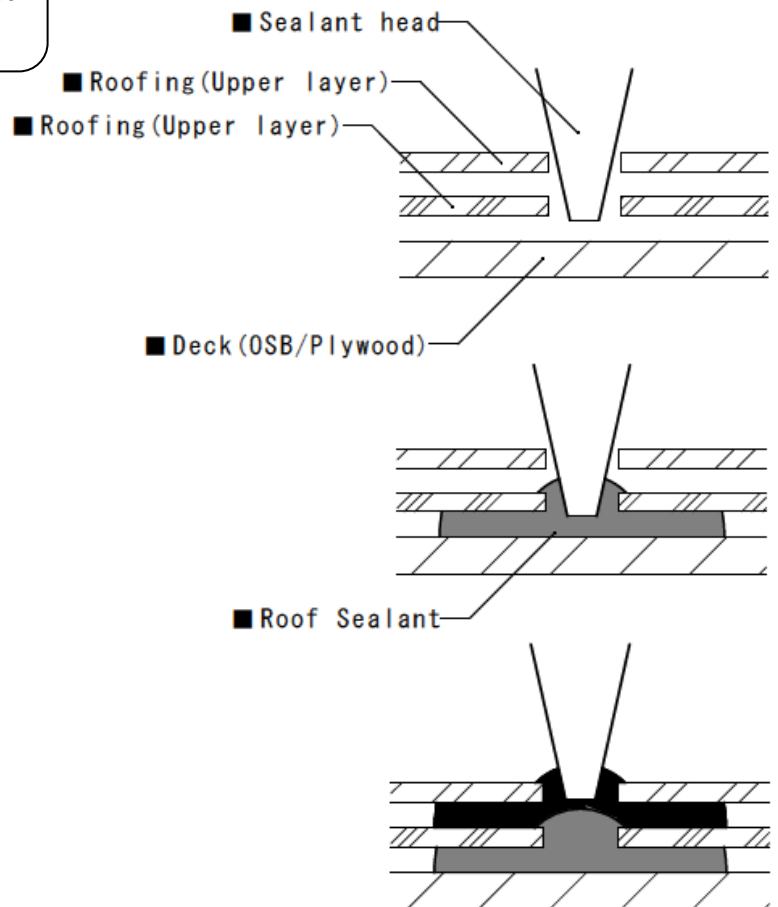

- ③ Set the bracket with 5 ea. (for Roof DECK), of M5.0×60 mm stainless wood screw using 8 mm hex socket.

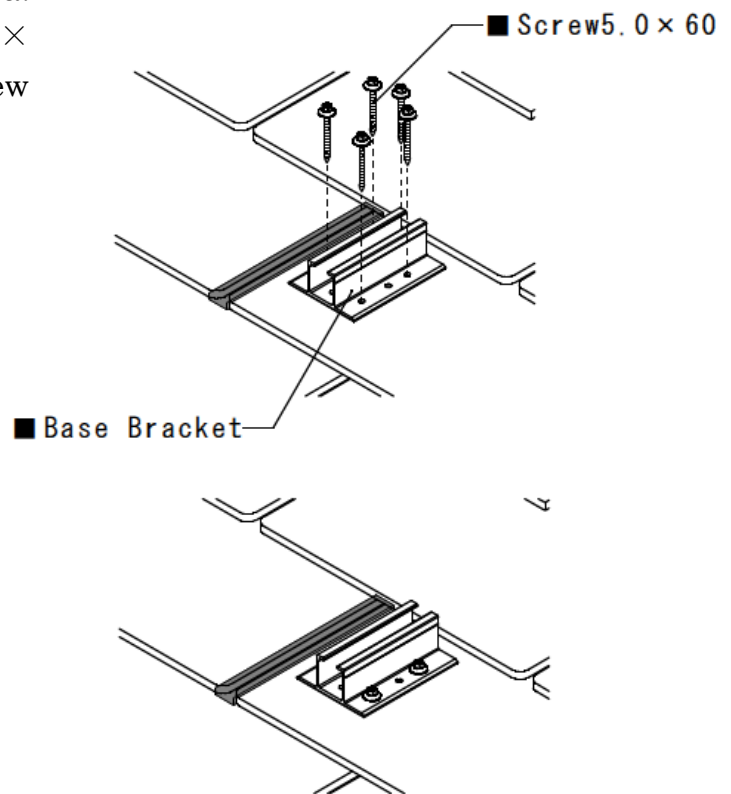

! Attention

When the base is installed on the deck, 5 screws must be used. The screws are fixed into the side 4 holes and 1 ridge side hole.

Note: Each base is shipped with 2 mounting screws. The installer must purchase additional screws when mounting it to the roof deck.

List of PV Modules compatible with this racking system.

The Roof Tech RT-APEX rail-less PV mounting system is certified to UL 2703 and may be used to ground and/or mount a PV module complying with UL 1703 only when the specific module has been evaluated for grounding and/or mounting in compliance with the included instructions. Unless otherwise noted, “xxx” refers to the module power rating and both black and silver frames are included in the certification. The following list of PV modules have been evaluated to UL 2703 Ed.1.

※Torque value of 16Nm:

Manufacturer	PV module Model No.
Aptos Solar	DNA-144-MF23-xxxW, DNA-144-BF23-xxxW, DNA-120-BF23-xxxW, DNA-120-MF23-xxxW
Axitec	AC-xxxP/156-60S, AC-xxxM/156-60S AC-xxxP/156-72S, AC-xxxMH/120(S or V)
Canadian Solar	CS6U-xxx CS6K-xxx, P-SD,P,M,MS, AB,CS6K-xxxP, CS6K-MS- xxx CS6X-xxxP CS1H-MS CS3K-MS CS6P-xxx-xxx P-SD CS3L-xxxMS, CS3N-xxxMS, CS1Y-xxxMS, CS3W-P, CS3W-MS, CS3W-PB-AG, CS3W-MB-AG
Heliene	60P, 60M
JA Solar	JAP6 60-xxx, JAM6-60-xxx/SI, JAM6(K)-60/xxx, JAP6(k)-72-xxx/4BB, JAP72SYY-xxx/ZZ, JAP6(k)-60- xxx/4BB, JAP60SYY-xxx/ZZ, JAM6(k)-72-xxx/ZZ, JAM72SYY-xxx/ZZ, JAM6(k)-60-xxx/ZZ, JAM60SYY- xxx/ZZ, JAM 72S09 i. YY: 01 white backsheet, 02 black backsheet, 03 half-cell and white backsheet, 09 M4 cell, 10 M4 1/2 cell ii. ZZ: SC standard cell, PR = perc, BP = bifacial, HiT = HIT, IB = IBC, MW = MWT
Japan Solar	JS-xxxU-LI60 JS-xxxM-LI60 JS-xxxU-LI72 JS-xxxM-LI72 JS-xxxM-TC160 JS-xxxU-RJ160 JPS285/290M-60
Peimar	SG360M, SG270/280P, SG290/300M (FB), SG300/310M (FB), SG325/330P

APPENDIX

REC	<p>RECxxx Alpha Series, RECxxx N-Peak Energy Series RECxxx Alpha72 Series, RECxxxTwinPeak 3M Series RECxxxAA Alpha Black Series, RECxxxNP Black Series RECxxxTP 2SM 72, RECxxxTP3M Black series RECxxxAA Pure Black, RECxxx NP2, RECxxxNP2 Black, REC xxxTP4 Black</p>
-----	---

Manufacturer	PV module Model No.
Silfab	<p>SLA-M xxx SLG-M xxx SLA-X SLG-X SLA-P xxx SLG-P xxx SSA-M SSG-M SSA-P xxx SSG-P xxx SIL-xxx NL</p>
Solaria	<p>XT-xxxR-PD XT-xxxR-BD XT-xxxR-PX XT-xxxR-PM-AC XT-xxxR-PM XT-xxxR-BX</p>
SolarWorld	<p>SW xxx POLY (33mm black frame), SW 275-280 MONO BLACK (33mm frame), SW xxx-xxx XL MONO (33mm frame), SW xxx-xxx MONO (33mm frame), SW xxx-xxx MONO (33mm frame, 5 buster), SW xxx- xxx MONO BLACK (33mm frame)</p>
Suniva	<p>OPT xxx-60-4-100, OPT xxx-60-4-1B0, OPT xxx-72-4- 100</p>
Trina	<p>TSM-DE15H(II), TSM-DE15M(II) TSM-DD06M.05(II), TSM-DD06M.08(II) TSM-DEG15HC.20(II), TSM-DEG15MC.20(II) TSM-DEG6MC.20(II)</p>
VSUN	<p>VSUNxxx-60M-BB, VSUNxxx-72M</p>
Yingli	<p>YL xxxP-29b, YL xxxP-35b, YLxxxD-30b(xxx=Pmax), YLxxxD-36b(xxx=Pmax)</p>

APPENDIX

※Torque value of 18Nm:

Manufacturer	PV module Model No.
Astronova	CHSM6612P, CHSM6612P/HV
Astroenergy	CHSM6612M-HV-xxx, CHSM6612P-HV-xxx, CHSM72M(DG)/F-BH, CHSM72M-HC xxxW, CHSM72M(DG)/F-BH xxxW
BYD	P6K Series (35mm), MHK-36
Certainteed	CTxxxMxx-01, CTxxxPxx-01, CTxxxMxx-02 Where "xx" denotes frame and backsheet color. CT-03 Series CTxxxHC11-04
Dehui Solar	DH-60M xxx-xxxW
Eco Solargy	ORION 1000 ECOXXXH156P-60, APOLLO 1000 ECOXXXT156M-60, and APOLLO 1000 ECOXXXA156M- 60.
ET Solar	ETAC Module, ET Module.
GCL	40mm frame: GCL-P6/72 35mm frame: GCL-P6/72, GCL-P6/72H, GCL-M6/72, GCL-M6/72H 35mm frame (Black frame): GCL-P6/60, GCL-M6/60
Hansol	TD-AN3 (40mm), TD-AN4, UB-AN1 (35mm), UD-AN1 (40mm), UB-AN1, UD-AN1
HT Solar	HT60-156(M) (NDV) (-F), HT 72-156(M/P)
Hyundai	HiA-SxxxHI, KG, MG, TG, RI, RG, TI, MI, KI series (35mm and 40mm).
ITEK	iT-xxx, iT-xxx-HE, iT-xxx-SE, iT-xxx-SE-72 (40mm).
Jinko	Eagle PERC 280-300, JKMxxxM, Eagle PERC 280-300, JKMxxxM, Eagle JKM275PP-60, JKMxxxPP-60, Eagle JKM275PP-60, JKMxxxPP-60, Eagle JKM330PP-72, JKMxxxPP-72, Eagle JKM330PP-72, JKMxxxPP-72, Eagle JKM280PP-60-J4, Smart MX 255-320, JKM xxxM-60HBL, JKMxxxM-72 HL-V, JKMxxxM- 72HL-TV, JKM xxxM-66H, JKM xxxM-66H-V
Kyocera	KD 260GX-LFB2, KD265GX-LFB2, KU265-6MCA

※Torque value of 18Nm:

Manufacturer	PV module Model No.
LG	<p>MONO X, MONO X 2, Mono X Plus, Mono Neon 2, Mono Neon 2</p> <p>LGxxxN1C-V5, LGxxxN1K-V5, LGxxxN2W-V5, LGxxxN2T-V5, LGxxxQ1C-V5, LGxxxQ1K-V5, LG xxx S1C-L4, LG xxx N1C-G4, LGxxxN1T-V5, LGxxxN2W-B3, LGxxxN2W-G4, LG xxx S1C-A5, LG xxx N1C-A5, LGxxxQ1C(Q1K)-A5, LGxxxN1C(N1K)-A5, LGxxxS1C-A5, LGxxxA1C-A5, LGxxxN2T-A5, LGxxxN2W-A5, LGxxxS2W-A5, LGxxxE1C-A5, LGxxxN1C(N1K)-G4, LGxxxS2W-G4, LGxxxS1C-G4, LGxxxE1K-A5,</p> <p><u>In Bold Optional 16Nm Torque</u></p> <p>LGxxxQ1K-A6, LGxxxQ1C-A6. LGxxxQAC-A6, LGxxxQAK-A6, LGxxxA1C-A6, LGxxxN1C-A6, LGxxxN1K-A6, LGxxxM1C-A6, LGxxxM1K-A6, LGxxxN2W-E6, LGxxxN2T-E6, LG xxxA1C-V5, LGxxxN1K-L5, LGxxxN1C-N5, LGxxxN1K-A6, LGxxxN1C-A6, LGxxxW-BIFACIAL, LGxxxW-MONO, LGxxxN1C(K)-V5, LGxxxQ1C(K)-V5, LGxxxNxW(T)-VS, LGxxxQ1C(K)-N5, LGxxxN1K-L5, LGxxxN2W(T)-L5</p>
LONGi	<p>LR6-60PH 290-310M, LR6-72HV 330-350M, LR6-72PH 360-380M LR6-60HPB-xxxM, LR6-60HPH-xxxM, LR6-72HPH-xxxM, LR4-60HPB/HIB-xxxM, LR4-60HPH/HH-xxxM, LR4-72HPH/HH-xxxM</p>
Mission Solar	MSE series
Mitsubishi	MJE, MLE
NSP	D6M and D6P
Panasonic	<p>VBHN240SA11, VBHN325SA16 and 16B, VBHN330SA16 and 16B VBHNxxxSA17, VBHNxxxSA17E, VBHNxxxKA03, VBHNxxxRA18N, VBHxxxRA18N, VBHxxxRA03K, VBHxxxRA18E, VBHxxxRA03F, VBHxxxRA18G, EVPVxxx, EVPVxxxK, VBHNxxxKA03E</p>

APPENDIX

Phono Solar	PS-xxx-60, PS-xxx-72
Renesola	Virtus II with module ratings of 250-260 in increments of 5. 156 series with module ratings of 270-275.
S-Energy	SN3xxM-10/SN3xxP-10 (40mm), SNxxxM-10/SN2xxP- 10 (40mm), SNxxxP-15 (40mm)
Seraphim	SRP-6MA xxxW, SEG-6MA-xxx, SEG-BMA-xxx, SRP 6MB xxxW, SEG-6MB-xxx, SEG-BMB-xxx, SRP-6MB-BB xxxW, SRP-6PA xxxW, SEG-6PA-xxx, SRP-6MA-xxx, SRP-BMA-xxx, SRP-6MB-xxx, SRP-BMB-xxx
Sharp	60 and 72 NUSA-xxx/NUSC-xxx
Sonali	SS 230 - 265
Sunpower	E20-xxx-COM, X21-xxx, X22-360-C-AC. **Evaluated with both the G3 and G5 frame** SPR-P17-xxx-COM (xxx: module power rating)

Manufacturer	PV module Model No.
SunSpark	Mono Module SST-xxxW (60 and 72 cells)
Suntech	STP 35/40
Winaico	WSP-xxxM6 PERC, WSP-xxxM6, WST-xxxP6BF, WST- xxxP6SF

※Torque value of 18Nm and mounting on the long side of PV module:

Manufacturer	PV module Model No.
Hanwha Q-Cells	Q.PEAK DUO R XXX (R is the Model listed and xxx is the Power) G5, BLK-G5, G6, BLK-G6, G6+, BLK-G6+, G7, BLK-G7, G8, BLK-G8, G8+, BLK-G8+ L-G5.X, L-G6.X, L-G7.X, L-G8.X, L-G8.3/BFG, L-G8.3/BFF (Where X can be 0 – 9) G5/SC, BLK-G5/SC, G6+/SC, BLK-G6+/SC, BLK-G6+/AC

Note : Hanwha Q-Cells modules in Portrait option for bonding is the DynoBond. Please see Page 63 and Page 66.

NOTES

Customer Support

If you need assistance at any point of your installation or have suggestions on how can we improve your experience, call Roof-Tech customer support.

(858) 935-6064

<http://roof-tech.us/>

